



SEBU8733-01
September 2013



Operation and Maintenance Manual

C7.1 Industrial Engine

881 1-Up (Engine)

Important Safety Information

Most accidents that involve product operation, maintenance and repair are caused by failure to observe basic safety rules or precautions. An accident can often be avoided by recognizing potentially hazardous situations before an accident occurs. A person must be alert to potential hazards, including human factors that can affect safety. This person should also have the necessary training, skills and tools to perform these functions properly.

Improper operation, lubrication, maintenance or repair of this product can be dangerous and could result in injury or death.

Do not operate or perform any lubrication, maintenance or repair on this product, until you verify that you are authorized to perform this work, and have read and understood the operation, lubrication, maintenance and repair information.

Safety precautions and warnings are provided in this manual and on the product. If these hazard warnings are not heeded, bodily injury or death could occur to you or to other persons.

The hazards are identified by the "Safety Alert Symbol" and followed by a "Signal Word" such as "DANGER", "WARNING" or "CAUTION". The Safety Alert "WARNING" label is shown below.



The meaning of this safety alert symbol is as follows:

Attention! Become Alert! Your Safety is Involved.

The message that appears under the warning explains the hazard and can be either written or pictorially presented.

A non-exhaustive list of operations that may cause product damage are identified by "NOTICE" labels on the product and in this publication.

Caterpillar cannot anticipate every possible circumstance that might involve a potential hazard. The warnings in this publication and on the product are, therefore, not all inclusive. You must not use this product in any manner different from that considered by this manual without first satisfying yourself that you have considered all safety rules and precautions applicable to the operation of the product in the location of use, including site-specific rules and precautions applicable to the worksite. If a tool, procedure, work method or operating technique that is not specifically recommended by Caterpillar is used, you must satisfy yourself that it is safe for you and for others. You should also ensure that you are authorized to perform this work, and that the product will not be damaged or become unsafe by the operation, lubrication, maintenance or repair procedures that you intend to use.

The information, specifications, and illustrations in this publication are on the basis of information that was available at the time that the publication was written. The specifications, torques, pressures, measurements, adjustments, illustrations, and other items can change at any time. These changes can affect the service that is given to the product. Obtain the complete and most current information before you start any job. Cat dealers have the most current information available.



When replacement parts are required for this product Caterpillar recommends using Cat replacement parts.

Failure to follow this warning may lead to premature failures, product damage, personal injury or death.

In the United States, the maintenance, replacement, or repair of the emission control devices and systems may be performed by any repair establishment or individual of the owner's choosing.

Table of Contents

Foreword.....	4
---------------	---

Safety Section

Safety Messages.....	5
----------------------	---

General Hazard Information	8
----------------------------------	---

Burn Prevention.....	12
----------------------	----

Fire Prevention and Explosion Prevention	13
---	----

Crushing Prevention and Cutting Prevention .	15
--	----

Mounting and Dismounting.....	15
-------------------------------	----

High Pressure Fuel Lines	15
--------------------------------	----

Before Starting Engine	17
------------------------------	----

Engine Starting	17
-----------------------	----

Engine Stopping	18
-----------------------	----

Electrical System.....	18
------------------------	----

Engine Electronics.....	19
-------------------------	----

Product Information Section

General Information.....	21
--------------------------	----

Product Identification Information.....	30
---	----

Operation Section

Lifting and Storage.....	33
--------------------------	----

Features and Controls.....	37
----------------------------	----

Engine Diagnostics.....	59
-------------------------	----

Engine Starting	64
-----------------------	----

Engine Operation.....	67
-----------------------	----

Cold Weather Operation.....	69
-----------------------------	----

Engine Stopping	74
-----------------------	----

Maintenance Section

Refill Capacities.....	76
------------------------	----

Maintenance Recommendations.....	83
----------------------------------	----

Maintenance Interval Schedule	87
-------------------------------------	----

Warranty Section

Warranty Information.....	131
---------------------------	-----

Reference Information Section

Engine Ratings	132
----------------------	-----

Customer Service	133
------------------------	-----

Reference Materials	135
---------------------------	-----

Index Section

Index.....	138
------------	-----

Foreword

Literature Information

This manual contains safety, operation instructions, lubrication and maintenance information. This manual should be stored in or near the engine area in a literature holder or literature storage area. Read, study and keep it with the literature and engine information.

English is the primary language for all Cat publications. The English used facilitates translation and consistency in electronic media delivery.

Some photographs or illustrations in this manual show details or attachments that may be different from your engine. Guards and covers may have been removed for illustrative purposes. Continuing improvement and advancement of product design may have caused changes to your engine which are not included in this manual. Whenever a question arises regarding your engine, or this manual, please consult with your Cat dealer for the latest available information.

Safety

This safety section lists basic safety precautions. In addition, this section identifies hazardous, warning situations. Read and understand the basic precautions listed in the safety section before operating or performing lubrication, maintenance and repair on this product.

Operation

Operating techniques outlined in this manual are basic. They assist with developing the skills and techniques required to operate the engine more efficiently and economically. Skill and techniques develop as the operator gains knowledge of the engine and its capabilities.

The operation section is a reference for operators. Photographs and illustrations guide the operator through procedures of inspecting, starting, operating and stopping the engine. This section also includes a discussion of electronic diagnostic information.

Maintenance

The maintenance section is a guide to engine care. The illustrated, step-by-step instructions are grouped by fuel consumption, service hours and/or calendar time maintenance intervals. Items in the maintenance schedule are referenced to detailed instructions that follow.

Use fuel consumption or service hours to determine intervals. Calendar intervals shown (daily, annually, etc.) may be used instead of service meter intervals if they provide more convenient schedules and approximate the indicated service meter reading.

Recommended service should be performed at the appropriate intervals as indicated in the Maintenance Interval Schedule. The actual operating environment of the engine also governs the Maintenance Interval Schedule. Therefore, under extremely severe, dusty, wet or freezing cold operating conditions, more frequent lubrication and maintenance than is specified in the Maintenance Interval Schedule may be necessary.

The maintenance schedule items are organized for a preventive maintenance management program. If the preventive maintenance program is followed, a periodic tune-up is not required. The implementation of a preventive maintenance management program should minimize operating costs through cost avoidances resulting from reductions in unscheduled downtime and failures.

Maintenance Intervals

Perform maintenance on items at multiples of the original requirement. Each level and/or individual items in each level should be shifted ahead or back depending upon your specific maintenance practices, operation and application. We recommend that the maintenance schedules be reproduced and displayed near the engine as a convenient reminder. We also recommend that a maintenance record be maintained as part of the engine's permanent record.

See the section in the Operation and Maintenance Manual, "Maintenance Records" for information regarding documents that are generally accepted as proof of maintenance or repair. Your authorized Cat dealer can assist you in adjusting your maintenance schedule to meet the needs of your operating environment.

Overhaul

Major engine overhaul details are not covered in the Operation and Maintenance Manual except for the interval and the maintenance items in that interval. Major repairs are best left to trained personnel or an authorized Cat dealer. Your Cat dealer offers a variety of options regarding overhaul programs. If you experience a major engine failure, there are also numerous after failure overhaul options available from your Cat dealer. Consult with your dealer for information regarding these options.

California Proposition 65 Warning

Diesel engine exhaust and some of its constituents are known to the State of California to cause cancer, birth defects, and other reproductive harm.

Battery posts, terminals and related accessories contain lead and lead compounds. **Wash hands after handling.**

Safety Section

i04889628

Safety Messages

SMCS Code: 1000; 7405

There may be several specific warning signs on your engine. The exact location and a description of the warning signs are reviewed in this section. Please become familiar with all warning signs.

Ensure that all of the warning signs are legible. Clean the warning signs or replace the warning signs if the words cannot be read or if the illustrations are not visible. Use a cloth, water, and soap to clean the warning signs. Do not use solvents, gasoline, or other harsh chemicals. Solvents, gasoline, or harsh chemicals could loosen the adhesive that secures the warning signs. The warning signs that are loosened could drop off the engine.

Replace any warning sign that is damaged or missing. If a warning sign is attached to a part of the engine that is replaced, install a new warning sign on the replacement part. Your Caterpillar dealer can provide new warning signs.

Universal Warning 1



Do not operate or work on this equipment unless you have read and understand the instructions and warnings in the Operation and Maintenance Manuals. Failure to follow the instructions or heed the warnings could result in serious injury or death.

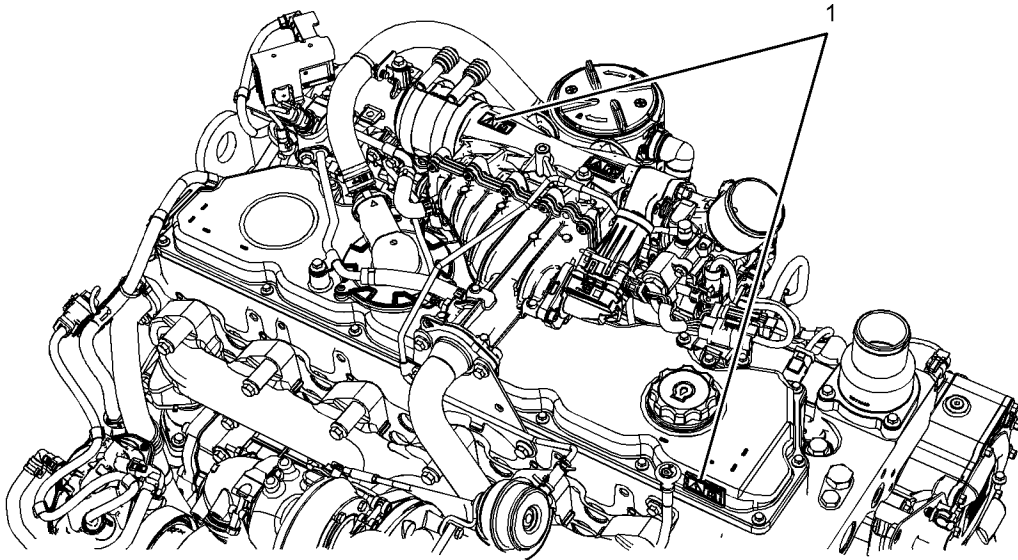

Illustration 1

g03022899

Typical example

The universal warning label is install in two positions on the engine. On the valve mechanism cover and on the intake manifold, refer to illustration 1 .

Ether Warning 2

WARNING

Do not use aerosol types of starting aids such as ether. Such use could result in an explosion and personal injury.

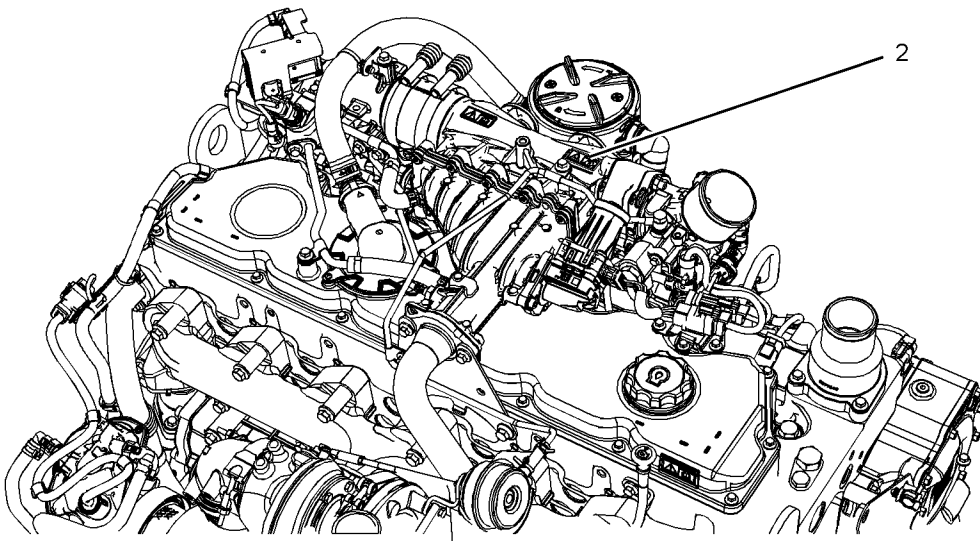

Illustration 2

g03023096

Typical example

The ether warning label is installed on the intake manifold, refer to illustration 2 .

Hand (High Pressure) 3

WARNING

Contact with high pressure fuel may cause fluid penetration and burn hazards. High pressure fuel spray may cause a fire hazard. Failure to follow these inspection, maintenance and service instructions may cause personal injury or death.

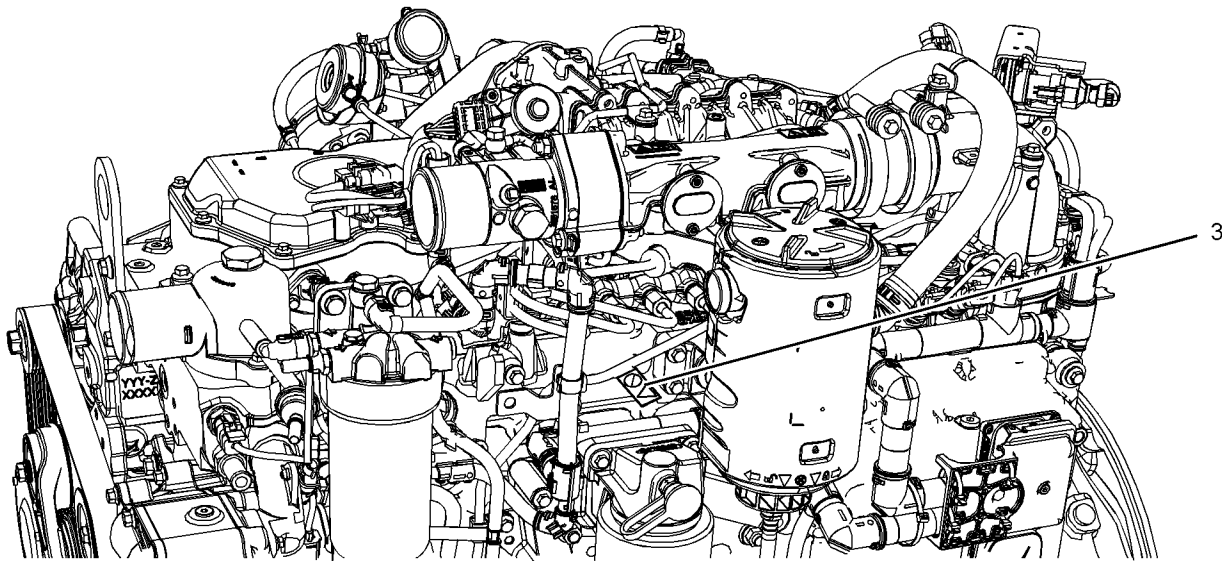

Illustration 3

g03023097

Typical example

The hand high-pressure warning label is a rap around label installed on the main injection line, refer to illustration 3 .

i05474090

General Hazard Information

SMCS Code: 1000; 4450; 7405

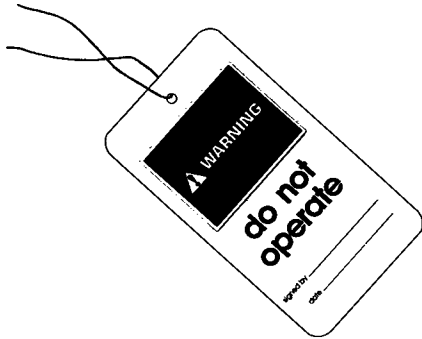

Illustration 4

g00104545

Attach a “Do Not Operate” warning tag or a similar warning tag to the start switch or to the controls before the engine is serviced or before the engine is repaired. These warning tags (Special Instruction, SEHS7332) are available from your Cat dealer. Attach the warning tags to the engine and to each operator control station. When appropriate, disconnect the starting controls.

Do not allow unauthorized personnel on the engine, or around the engine when the engine is being serviced.

- Tampering with the engine installation or tampering with the OEM supplied wiring can be dangerous. Personal injury, death and/or engine damage could result.
- Vent the engine exhaust to the outside when the engine is operated in an enclosed area.
- If the engine is not running, do not release the secondary brake or the parking brake systems unless the vehicle is blocked or unless the vehicle is restrained.
- Wear a hard hat, protective glasses, and other protective equipment, as required.
- When work is performed around an engine that is operating, wear protective devices for ears in order to help prevent damage to hearing.
- Do not wear loose clothing or jewelry that can snag on controls or on other parts of the engine.
- Ensure that all protective guards and all covers are secured in place on the engine.
- Never put maintenance fluids into glass containers. Glass containers can break.
- Use all cleaning solutions with care.
- Report all necessary repairs.

Unless other instructions are provided, perform the maintenance under the following conditions:

- The engine is stopped. Ensure that the engine cannot be started.
- The protective locks or the controls are in the applied position.
- Engage the secondary brakes or parking brakes.
- Block the vehicle or restrain the vehicle before maintenance or repairs are performed.
- Disconnect the batteries when maintenance is performed or when the electrical system is serviced. Disconnect the battery ground leads. Tape the leads in order to help prevent sparks. If equipped, allow the diesel exhaust fluid to be purged before disconnecting the battery.
- If equipped, disconnect the connectors for the unit injectors that are located on the valve cover base. This action will help prevent personal injury from the high voltage to the unit injectors. Do not come in contact with the unit injector terminals while the engine is operating.
- Do not attempt any repairs or any adjustments to the engine while the engine is operating.
- Do not attempt any repairs that are not understood. Use the proper tools. Replace any equipment that is damaged or repair the equipment.
- For initial start-up of a new engine or for starting an engine that has been serviced, make provisions to stop the engine if an overspeed occurs. The stopping of the engine may be accomplished by shutting off the fuel supply and/or the air supply to the engine. Ensure that only the fuel supply line is shut off. Ensure that the fuel return line is open.
- Start the engine from the operators station (cab). Never short across the starting motor terminals or the batteries. This action could bypass the engine neutral start system and/or the electrical system could be damaged.

Engine exhaust contains products of combustion which may be harmful to your health. Always start the engine and operate the engine in a well ventilated area. If the engine is in an enclosed area, vent the engine exhaust to the outside.

Cautiously remove the following parts. To help prevent spraying or splashing of pressurized fluids, hold a rag over the part that is being removed.

- Filler caps
- Grease fittings
- Pressure taps
- Breathers
- Drain plugs

Use caution when cover plates are removed. Gradually loosen, but do not remove the last two bolts or nuts that are located at opposite ends of the cover plate or the device. Before removing the last two bolts or nuts, pry the cover loose in order to relieve any spring pressure or other pressure.

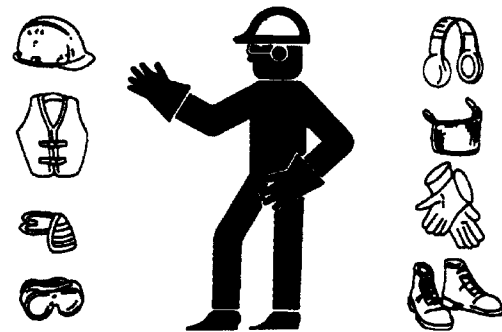

Illustration 5

g00702020

- Wear a hard hat, protective glasses, and other protective equipment, as required.
- When work is performed around an engine that is operating, wear protective devices for ears in order to help prevent damage to hearing.
- Do not wear loose clothing or jewelry that can snag on controls or on other parts of the engine.
- Ensure that all protective guards and all covers are secured in place on the engine.
- Never put maintenance fluids into glass containers. Glass containers can break.
- Use all cleaning solutions with care.
- Report all necessary repairs.

Unless other instructions are provided, perform the maintenance under the following conditions:

- The engine is stopped. Ensure that the engine cannot be started.
- Disconnect the batteries when maintenance is performed or when the electrical system is serviced. Disconnect the battery ground leads. Tape the leads in order to help prevent sparks.
- Do not attempt any repairs that are not understood. Use the proper tools. Replace any equipment that is damaged or repair the equipment.

Pressurized Air and Water

Pressurized air and/or water can cause debris and/or hot water to be blown out. This action could result in personal injury.

When pressurized air and/or pressurized water is used for cleaning, wear protective clothing, protective shoes, and eye protection. Eye protection includes goggles or a protective face shield.

The maximum air pressure for cleaning purposes must be below 205 kPa (30 psi). The maximum water pressure for cleaning purposes must be below 275 kPa (40 psi).

Fluid Penetration

Pressure can be trapped in the hydraulic circuit long after the engine has been stopped. The pressure can cause hydraulic fluid or items such as pipe plugs to escape rapidly if the pressure is not relieved correctly.

Do not remove any hydraulic components or parts until pressure has been relieved or personal injury may occur. Do not disassemble any hydraulic components or parts until pressure has been relieved or personal injury may occur. Refer to the OEM information for any procedures that are required to relieve the hydraulic pressure.

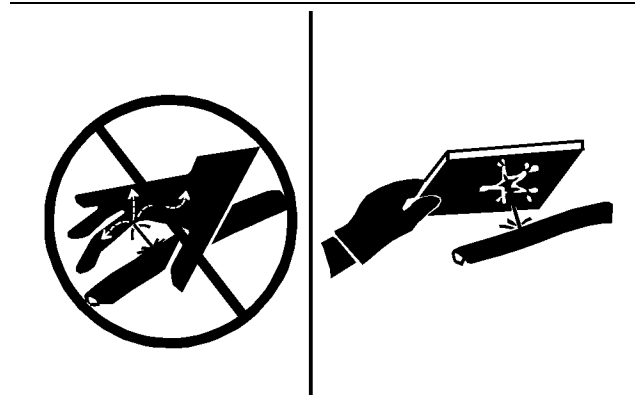

Illustration 6

g00687600

Always use a board or cardboard when you check for a leak. Leaking fluid that is under pressure can penetrate body tissue. Fluid penetration can cause serious injury and possible death. A pin hole leak can cause severe injury. If fluid is injected into your skin, you must get treatment immediately. Seek treatment from a doctor that is familiar with this type of injury.

Containing Fluid Spillage

Care must be taken to ensure that fluids are contained during performance of inspection, maintenance, testing, adjusting, and repair of the product. Be prepared to collect the fluid with suitable containers before opening any compartment or disassembling any component containing fluids.

Refer to Special Publication, NENG2500, "Cat Dealer Service Tool Catalog" for tools and supplies suitable to collect and contain fluids on Cat products.

Dispose of all fluids according to local regulations and mandates.

Inhalation

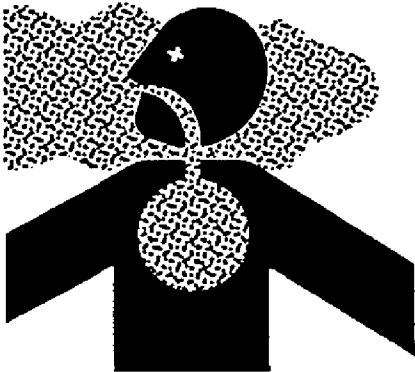

Illustration 7

g00702022

Exhaust

Use caution. Exhaust fumes can be hazardous to health. If you operate the equipment in an enclosed area, adequate ventilation is necessary.

Asbestos Information

Cat equipment and replacement parts that are shipped from Caterpillar are asbestos free. Caterpillar recommends the use of only genuine Cat replacement parts. Use the following guidelines when you handle any replacement parts that contain asbestos or when you handle asbestos debris.

Use caution. Avoid inhaling dust that might be generated when you handle components that contain asbestos fibers. Inhaling this dust can be hazardous to your health. The components that may contain asbestos fibers are brake pads, brake bands, lining material, clutch plates, and some gaskets. The asbestos that is used in these components is usually bound in a resin or sealed in some way. Normal handling is not hazardous unless airborne dust that contains asbestos is generated.

If dust that may contain asbestos is present, there are several guidelines that should be followed:

- Never use compressed air for cleaning.
- Avoid brushing materials that contain asbestos.
- Avoid grinding materials that contain asbestos.
- Use a wet method in order to clean up asbestos materials.
- A vacuum cleaner that is equipped with a high efficiency particulate air filter (HEPA) can also be used.
- Use exhaust ventilation on permanent machining jobs.
- Wear an approved respirator if there is no other way to control the dust.
- Comply with applicable rules and regulations for the work place. In the United States, use Occupational Safety and Health Administration (OSHA) requirements. These OSHA requirements can be found in 29 CFR 1910.1001.
- Obey environmental regulations for the disposal of asbestos.
- Stay away from areas that might have asbestos particles in the air.

Dispose of Waste Properly

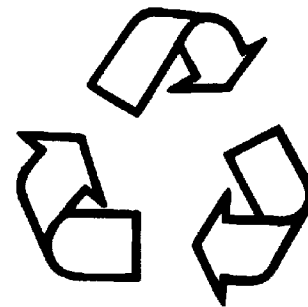

Illustration 8

g00706404

Improperly disposing of waste can threaten the environment. Potentially harmful fluids should be disposed of according to local regulations.

Always use leakproof containers when you drain fluids. Do not pour waste onto the ground, down a drain, or into any source of water.

i04891356

Burn Prevention

SMCS Code: 1000; 4450; 7405

Do not touch any part of an operating engine system. The engine, the exhaust, and the engine aftertreatment system can reach temperatures as high as 650° C (1202° F) under normal operating conditions.

Allow the engine system to cool before any maintenance is performed. Relieve all pressure in the air system, hydraulic system, lubrication system, fuel system, and the cooling system before the related items are disconnected.

WARNING

Contact with high pressure fuel may cause fluid penetration and burn hazards. High pressure fuel spray may cause a fire hazard. Failure to follow these inspection, maintenance and service instructions may cause personal injury or death.

After the engine has stopped, you must wait for 10 minutes in order to allow the fuel pressure to be purged from the high-pressure fuel lines before any service or repair is performed on the engine fuel lines.

Allow the pressure to be purged in the air system, in the hydraulic system, in the lubrication system, or in the cooling system before any lines, fittings, or related items are disconnected.

Induction System

WARNING

Sulfuric Acid Burn Hazard may cause serious personal injury or death.

The exhaust gas cooler may contain a small amount of sulfuric acid. The use of fuel with sulfur levels greater than 15 ppm may increase the amount of sulfuric acid formed. The sulfuric acid may spill from the cooler during service of the engine. The sulfuric acid will burn the eyes, skin and clothing on contact. Always wear the appropriate personal protective equipment (PPE) that is noted on a material safety data sheet (MSDS) for sulfuric acid. Always follow the directions for first aid that are noted on a material safety data sheet (MSDS) for sulfuric acid.

Coolant

When the engine is at operating temperature, the engine coolant is hot. The coolant is also under pressure. The radiator and all lines to the heaters, aftertreatment system or to the engine contain hot coolant.

Any contact with hot coolant or with steam can cause severe burns. Allow cooling system components to cool before the cooling system is drained.

Check that the coolant level after the engine has stopped and the engine has been allowed to cool.

Ensure that the filler cap is cool before removing the filler cap. The filler cap must be cool enough to touch with a bare hand. Remove the filler cap slowly in order to relieve pressure.

Cooling system conditioner contains alkali. Alkali can cause personal injury. Do not allow alkali to contact the skin, the eyes, or the mouth.

Oils

Hot oil and hot lubricating components can cause personal injury. Do not allow hot oil to contact the skin. Also, do not allow hot components to contact the skin.

Batteries

Electrolyte is an acid. Electrolyte can cause personal injury. Do not allow electrolyte to contact the skin or the eyes. Always wear protective glasses for servicing batteries. Wash hands after touching the batteries and connectors. Use of gloves is recommended.

Aftertreatment System

Allow the aftertreatment to cool down before any maintenance or repair is performed.

i05408756

Fire Prevention and Explosion Prevention

SMCS Code: 1000; 4450; 7405



Illustration 9

g00704000

All fuels, most lubricants, and some coolant mixtures are flammable.

Flammable fluids that are leaking or spilled onto hot surfaces or onto electrical components can cause a fire. Fire may cause personal injury and property damage.

A flash fire may result if the covers for the engine crankcase are removed within 15 minutes after an emergency shutdown.

Determine whether the engine will be operated in an environment that allows combustible gases to be drawn into the air inlet system. These gases could cause the engine to overspeed. Personal injury, property damage, or engine damage could result.

If the application involves the presence of combustible gases, consult your Caterpillar dealer for additional information about suitable protection devices.

Remove all flammable materials such as fuel, oil, and debris from the engine. Do not allow any flammable materials to accumulate on the engine.

Store fuels and lubricants in properly marked containers away from unauthorized persons. Store oily rags and any flammable materials in protective containers. Do not smoke in areas that are used for storing flammable materials.

Do not expose the engine to any flame.

Exhaust shields (if equipped) protect hot exhaust components from oil or fuel spray in a case of a line, a tube, or a seal failure. Exhaust shields must be installed correctly.

Do not weld on lines or tanks that contain flammable fluids. Do not flame cut lines or tanks that contain flammable fluid. Clean any such lines or tanks thoroughly with a nonflammable solvent prior to welding or flame cutting.

Wiring must be kept in good condition. All electrical wires must be properly routed and securely attached. Check all electrical wires daily. Repair any wires that are loose or frayed before you operate the engine. Clean all electrical connections and tighten all electrical connections.

Eliminate all wiring that is unattached or unnecessary. Do not use any wires or cables that are smaller than the recommended gauge. Do not bypass any fuses and/or circuit breakers.

Arcing or sparking could cause a fire. Secure connections, recommended wiring, and properly maintained battery cables will help to prevent arcing or sparking.

WARNING

Contact with high pressure fuel may cause fluid penetration and burn hazards. High pressure fuel spray may cause a fire hazard. Failure to follow these inspection, maintenance and service instructions may cause personal injury or death.

After the engine has stopped, you must wait for 10 minutes in order to allow the fuel pressure to be purged from the high-pressure fuel lines before any service or repair is performed on the engine fuel lines.

Inspect all lines and hoses for wear or for deterioration. The hoses must be properly routed. The lines and hoses must have adequate support and secure clamps. Tighten all connections to the recommended torque. Leaks can cause fires.

Oil filters and fuel filters must be properly installed. The filter housings must be tightened to the proper torque.



Illustration 10

g00704059

Use caution when you are refueling an engine. Do not smoke while you are refueling an engine. Do not refuel an engine near open flames or sparks. Always stop the engine before refueling.

Avoid static electricity risk when fueling. Ultra low sulfur diesel (ULSD) poses a greater static ignition hazard than earlier diesel formulation with a higher sulfur content. Avoid death or serious injury from the fire or explosion. Consult with your fuel or fuel system supplier to ensure that the delivery system is in compliance with fueling standards for proper grounding and bonding practices.

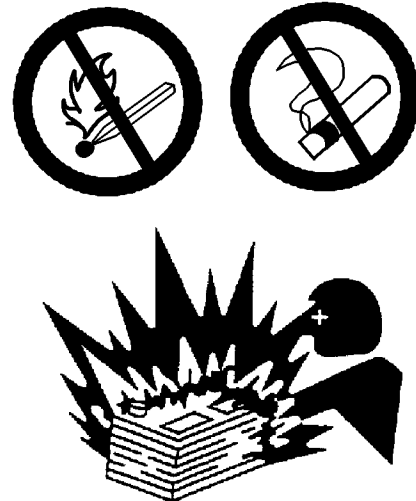

Illustration 11

g00704135

Gases from a battery can explode. Keep any open flames or sparks away from the top of a battery. Do not smoke in battery charging areas.

Never check the battery charge by placing a metal object across the terminal posts. Use a voltmeter or a hydrometer.

Improper jumper cable connections can cause an explosion that can result in injury. Refer to the Operation Section of this manual for specific instructions.

Do not charge a frozen battery. A frozen battery may cause an explosion.

The batteries must be kept clean. The covers (if equipped) must be kept on the cells. Use the recommended cables, connections, and battery box covers when the engine is operated.

Fire Extinguisher

Make sure that a fire extinguisher is available. Be familiar with the operation of the fire extinguisher. Inspect the fire extinguisher and service the fire extinguisher regularly. Obey the recommendations on the instruction plate.

Ether

Ether is flammable and poisonous.

Do not smoke while you are replacing an ether cylinder or while you are using an ether spray.

Do not store ether cylinders in living areas or in the engine compartment. Do not store ether cylinders in direct sunlight or in temperatures above 49 °C (120 °F). Keep ether cylinders away from open flames or sparks.

Dispose of used ether cylinders properly. Do not puncture an ether cylinder. Keep ether cylinders away from unauthorized personnel.

Lines, Tubes, and Hoses

Do not bend high-pressure lines. Do not strike high-pressure lines. Do not install any lines that are bent or damaged.

Repair any lines that are loose or damaged. Leaks can cause fires. Consult your Caterpillar dealer for repair or for replacement parts.

Check lines, tubes, and hoses carefully. Do not use your bare hand to check for leaks. Use a board or cardboard to check for leaks. Tighten all connections to the recommended torque.

Replace the parts if any of the following conditions are present:

- High-pressure fuel line or lines are removed.
- End fittings are damaged or leaking.
- Outer coverings are chafed or cut.
- Wires are exposed.
- Outer coverings are ballooning.
- Flexible part of the hose is kinked.
- Outer covers have embedded armoring.
- End fittings are displaced.

Make sure that all clamps, guards, and heat shields are installed correctly. During engine operation, this will help to prevent vibration, rubbing against other parts, and excessive heat.

i01359666

Crushing Prevention and Cutting Prevention

SMCS Code: 1000; 4450; 7405

Support the component properly when work beneath the component is performed.

Unless other maintenance instructions are provided, never attempt adjustments while the engine is running.

Stay clear of all rotating parts and of all moving parts. Leave the guards in place until maintenance is performed. After the maintenance is performed, reinstall the guards.

Keep objects away from moving fan blades. The fan blades will throw objects or cut objects.

When objects are struck, wear protective glasses in order to avoid injury to the eyes.

Chips or other debris may fly off objects when objects are struck. Before objects are struck, ensure that no one will be injured by flying debris.

i04016709

Mounting and Dismounting

SMCS Code: 1000; 4450; 7405

Do not climb on the engine or the engine aftertreatment. The engine and aftertreatment have not been designed with mounting or dismounting locations.

Refer to the OEM for the location of foot and hand holds for your specific application.

i03550790

High Pressure Fuel Lines

SMCS Code: 1274

WARNING

Contact with high pressure fuel may cause fluid penetration and burn hazards. High pressure fuel spray may cause a fire hazard. Failure to follow these inspection, maintenance and service instructions may cause personal injury or death.

Safety Section
High Pressure Fuel Lines

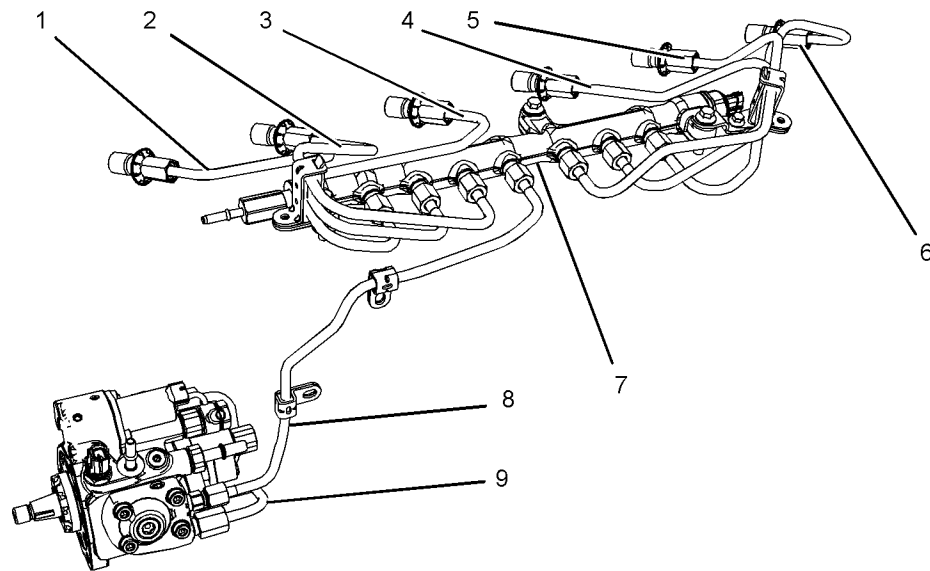

Illustration 12

g01877473

(1) High pressure line
(2) High pressure line
(3) High pressure line

(4) High pressure line
(5) High pressure line
(6) High pressure line

(7) High pressure fuel manifold (rail)
(8) High pressure line
(9) Fuel transfer line that is high pressure

The high pressure fuel lines are the fuel lines that are between the high pressure fuel pump and the high pressure fuel manifold and the fuel lines that are between the fuel manifold and cylinder head. These fuel lines are different from fuel lines on other fuel systems.

This is because of the following items:

- The high pressure fuel lines are constantly charged with high pressure.
- The internal pressures of the high pressure fuel lines are higher than other types of fuel system.
- The high pressure fuel lines are formed to shape and then strengthened by a special process.

Do not step on the high pressure fuel lines. Do not deflect the high pressure fuel lines. Do not bend or strike the high pressure fuel lines. Deformation or damage of the high pressure fuel lines may cause a point of weakness and potential failure.

Do not check the high pressure fuel lines with the engine or the starting motor in operation. After the engine has stopped, you must wait for 10 minutes in order to allow the fuel pressure to be purged from the high pressure fuel lines before any service or repair is performed on the engine fuel lines.

Do not loosen the high pressure fuel lines in order to remove air from the fuel system. This procedure is not required.

Visually inspect the high pressure fuel lines before the engine is started. This inspection should be each day.

If you inspect the engine in operation, always use the proper inspection procedure in order to avoid a fluid penetration hazard. Refer to Operation and Maintenance Manual, "General hazard Information".

- Inspect the high pressure fuel lines for damage, deformation, a nick, a cut, a crease, or a dent.
- Do not operate the engine with a fuel leak. If there is a leak do not tighten the connection in order to stop the leak. The connection must only be tightened to the recommended torque. Refer to Disassembly and Assembly, "Fuel injection lines - Remove and Fuel injection lines - Install".
- If the high pressure fuel lines are torqued correctly and the high pressure fuel lines are leaking the high pressure fuel lines must be replaced.
- Ensure that all clips on the high pressure fuel lines are in place. Do not operate the engine with clips that are damaged, missing or loose.
- Do not attach any other item to the high pressure fuel lines.
- Loosened high pressure fuel lines must be replaced. Also removed high pressure fuel lines must be replaced. Refer to Disassembly and assembly manual, "Fuel Injection Lines - Install".

i03560601

i03635086

Before Starting Engine

SMCS Code: 1000

NOTICE

For initial start-up of a new or rebuilt engine, and for start-up of an engine that has been serviced, make provision to shut the engine off should an overspeed occur. This may be accomplished by shutting off the air and/or fuel supply to the engine.

WARNING

Engine exhaust contains products of combustion which may be harmful to your health. Always start and operate the engine in a well ventilated area and, if in an enclosed area, vent the exhaust to the outside.

Inspect the engine for potential hazards.

Do not start the engine or move any of the controls if there is a "DO NOT OPERATE" warning tag or similar warning tag attached to the start switch or to the controls.

Before starting the engine, ensure that no one is on, underneath, or close to the engine. Ensure that the area is free of personnel.

If equipped, ensure that the lighting system for the engine is suitable for the conditions. Ensure that all lights work properly, if equipped.

All protective guards and all protective covers must be installed if the engine must be started in order to perform service procedures. To help prevent an accident that is caused by parts in rotation, work around the parts carefully.

Do not bypass the automatic shutoff circuits. Do not disable the automatic shutoff circuits. The circuits are provided in order to help prevent personal injury. The circuits are also provided in order to help prevent engine damage.

See the Service Manual for repairs and for adjustments.

Engine Starting

SMCS Code: 1000

WARNING

Do not use aerosol types of starting aids such as ether. Such use could result in an explosion and personal injury.

If a warning tag is attached to the engine start switch or to the controls DO NOT start the engine or move the controls. Consult with the person that attached the warning tag before the engine is started.

All protective guards and all protective covers must be installed if the engine must be started in order to perform service procedures. To help prevent an accident that is caused by parts in rotation, work around the parts carefully.

Start the engine from the operator's compartment or from the engine start switch.

Always start the engine according to the procedure that is described in the Operation and Maintenance Manual, "Engine Starting" topic in the Operation Section. Knowing the correct procedure will help to prevent major damage to the engine components. Knowing the procedure will also help to prevent personal injury.

To ensure that the jacket water heater (if equipped) and/or the lube oil heater (if equipped) is working correctly, check the water temperature gauge and/or the oil temperature gauge during the heater operation.

Engine exhaust contains products of combustion which can be harmful to your health. Always start the engine and operate the engine in a well ventilated area. If the engine is started in an enclosed area, vent the engine exhaust to the outside.

These engines are equipped with a glow plug starting aid in each individual cylinder that heats the intake air in order to improve starting. Some Caterpillar engines may have a cold starting system that is controlled by the ECM that allows a controlled flow of ether into the engine. The ECM will disconnect the glow plugs before the ether is introduced. This system would be installed at the factory.

i03648639

Engine Stopping

SMCS Code: 1000

To avoid overheating of the engine and accelerated wear of the engine components, stop the engine according to this Operation and Maintenance Manual, "Engine Stopping" topic (Operation Section).

Use the Emergency Stop Button (if equipped) **ONLY** in an emergency situation. **DO NOT** use the Emergency Stop Button for normal engine stopping. After an emergency stop, **DO NOT** start the engine until the problem that caused the emergency stop has been corrected.

On the initial start-up of a new engine or an engine that has been serviced, make provisions to stop the engine if an overspeed condition occurs.

i04891806

Electrical System

SMCS Code: 1000; 1400

Never disconnect any charging unit circuit or battery circuit cable from the battery when the charging unit is operating. A spark can cause the combustible gases that are produced by some batteries to ignite.

To help prevent sparks from igniting combustible gases that are produced by some batteries, the negative "-" cable should be connected last from the external power source to the primary position for grounding.

Check the electrical wires daily for wires that are loose or frayed. Tighten all loose electrical connections before the engine is started. Repair all frayed electrical wires before the engine is started. See the Operation and Maintenance Manual for specific starting instructions.

Grounding Practices

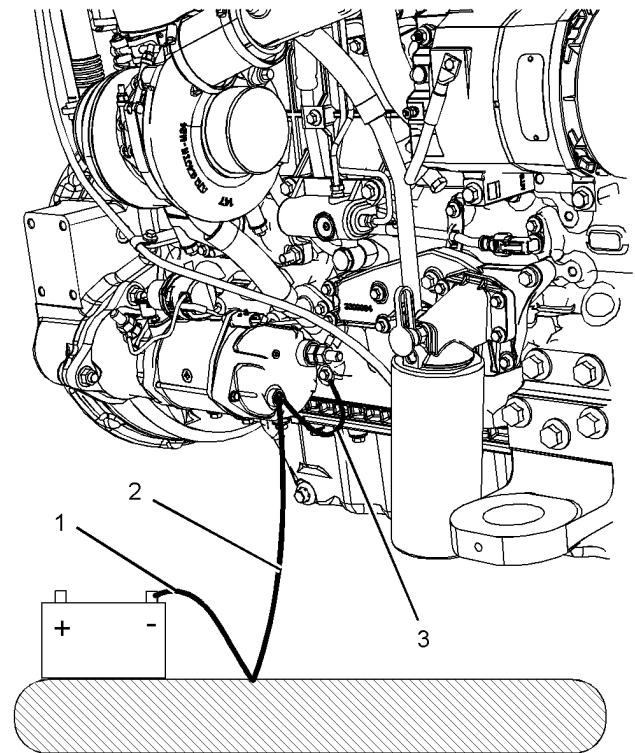

Illustration 13

g01888534

Typical example

- (1) Ground to battery
- (2) Ground to starting motor
- (3) Starting motor to engine block

i05206178

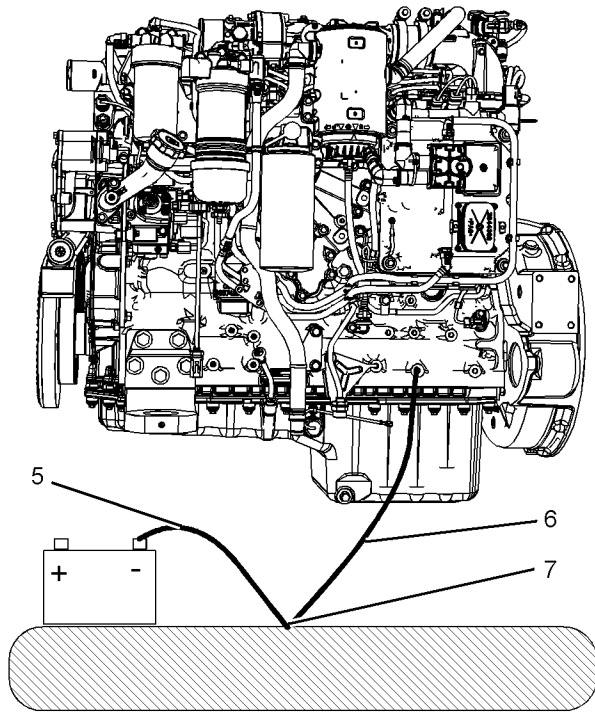

Illustration 14

g03027396

Typical example

- (5) Ground to the battery
- (6) Ground to the engine block
- (7) Primary position for grounding

Correct grounding for the engine electrical system is necessary for optimum engine performance and reliability. Incorrect grounding will result in uncontrolled electrical circuit paths and in unreliable electrical circuit paths.

Uncontrolled electrical circuit paths can result in damage to the crankshaft bearing journal surfaces and to aluminum components.

Engines that are installed without engine-to-frame ground straps can be damaged by electrical discharge.

To ensure that the engine and the engine electrical systems function correctly, an engine-to-frame ground strap with a direct path to the battery must be used. This path may be provided by way of a direct engine ground to the frame.

The connections for the grounds should be tight and free of corrosion. The engine alternator must be grounded to the negative “-” battery terminal. The wire used must be adequate to handle the full charging current of the alternator.

The power supply connections and the ground connections for the engine electronics should always be from the isolator to the battery.

Engine Electronics

SMCS Code: 1000; 1900

⚠ WARNING

Tampering with the electronic system installation or the OEM wiring installation can be dangerous and could result in personal injury or death and/or engine damage.

⚠ WARNING

Electrical Shock Hazard. The electronic unit injectors use DC voltage. The ECM sends this voltage to the electronic unit injectors. Do not come in contact with the harness connector for the electronic unit injectors while the engine is operating. Failure to follow this instruction could result in personal injury or death.

This engine has a comprehensive, programmable Engine Monitoring System. The Electronic Control Module (ECM) has the ability to monitor the engine operating conditions. If any of the engine parameters extend outside an allowable range, the ECM will initiate an immediate action.

The following actions are available for engine monitoring control:

- Warning
- Derate
- Shutdown

The following monitored engine operating conditions and components can limit engine speed and/or the engine power:

- Engine Coolant Temperature
- Engine Oil Pressure
- Engine Speed
- Intake Manifold Air Temperature
- Wastegate Regulator
- Supply Voltage to Sensors
- Fuel Temperature
- Fuel Pressure in Manifold (Rail)
- NOxReduction System
- Engine Aftertreatment System

The Engine Monitoring package can vary for different engine models and different engine applications. However, the monitoring system and the engine monitoring control will be similar for all engines.

Note: Many of the engine control systems and display modules that are available for Caterpillar Engines will work in unison with the Engine Monitoring System. Together, the two controls will provide the engine monitoring function for the specific engine application. Refer to Troubleshooting for more information on the Engine Monitoring System.

Product Information Section

General Information

i05347319

Model View Illustrations

SMCS Code: 1000

The following model views show typical features of the engine. Due to individual applications, your engine may appear different from the illustrations.

Single Turbocharged Engine with Installed Aftertreatment

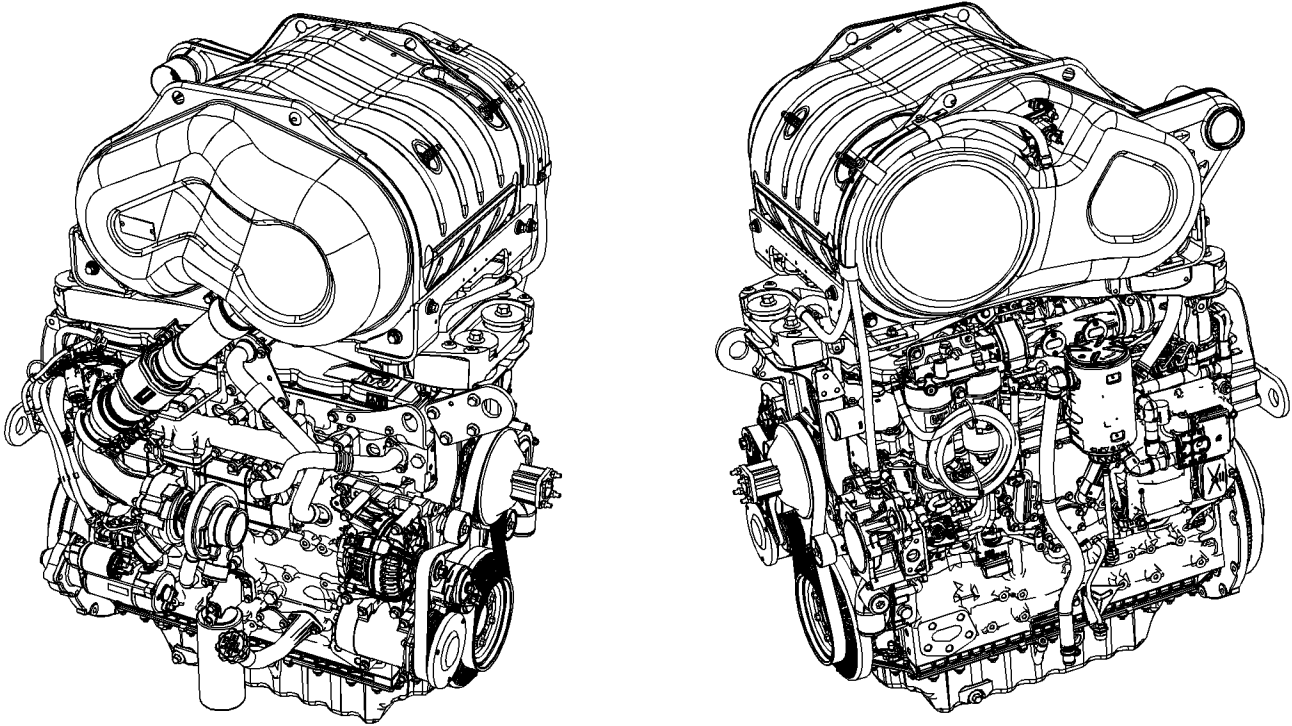

Illustration 15

Typical example

g03393436

Engine Views with Series Turbochargers

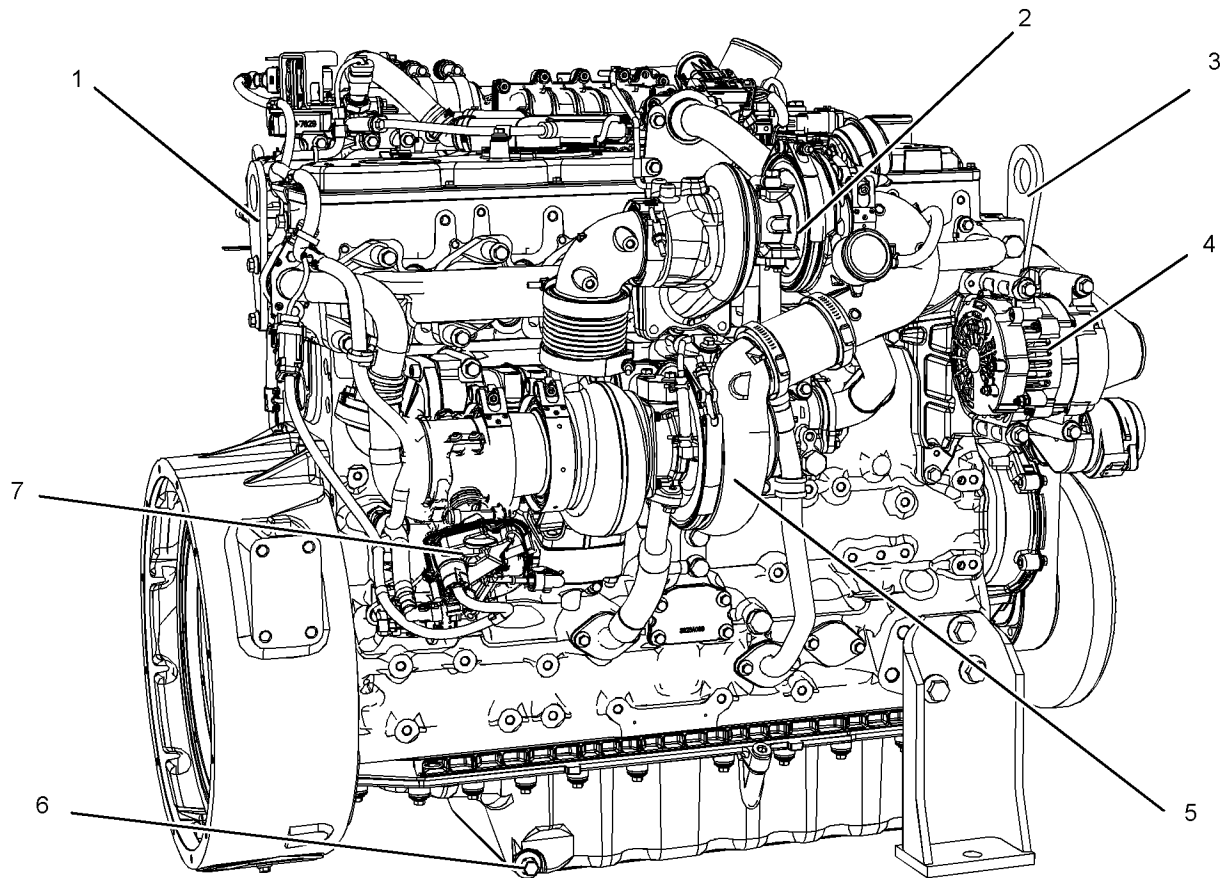

Illustration 16

g03387645

Typical example

- (1) Rear engine lifting eye
- (2) High-pressure turbocharger
- (3) Front engine lifting eye

- (4) Alternator
- (5) Low-pressure turbocharger
- (6) Oil drain plug

- (7) Back pressure valve

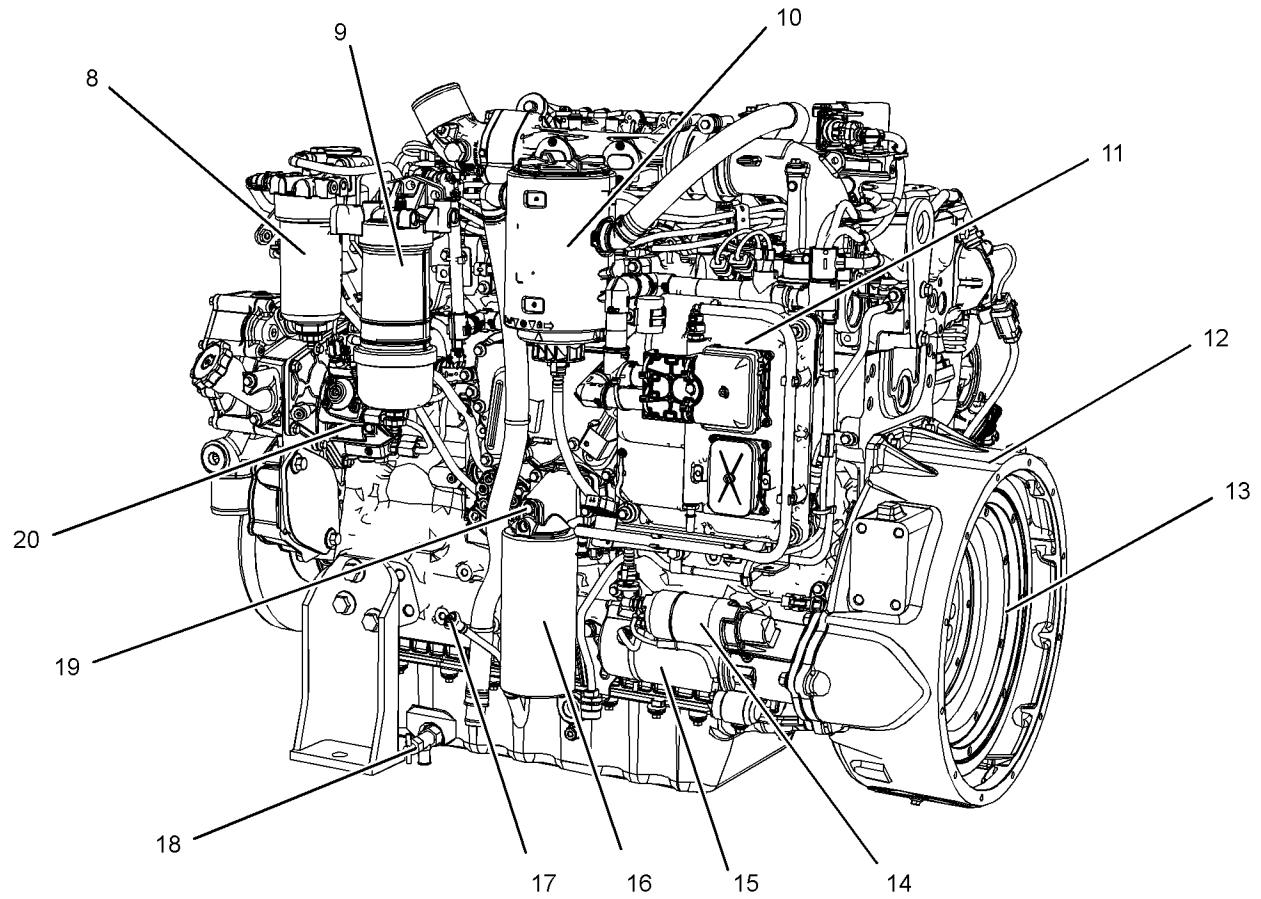

Illustration 17

g03387666

Typical example

- | | | |
|---|----------------------------------|--|
| (8) Secondary fuel filter | (12) Flywheel housing | (17) Oil level gauge (Dipstick) |
| (9) Primary fuel filter | (13) Flywheel | (18) Oil drain tap |
| (10) Crankcase breather | (14) Solenoid for starting motor | (19) location for the oil sampling valve |
| (11) Engine Electronic Control Module (ECM) | (15) Starting motor | (20) High-pressure fuel pump |
| | (16) Oil filter | |

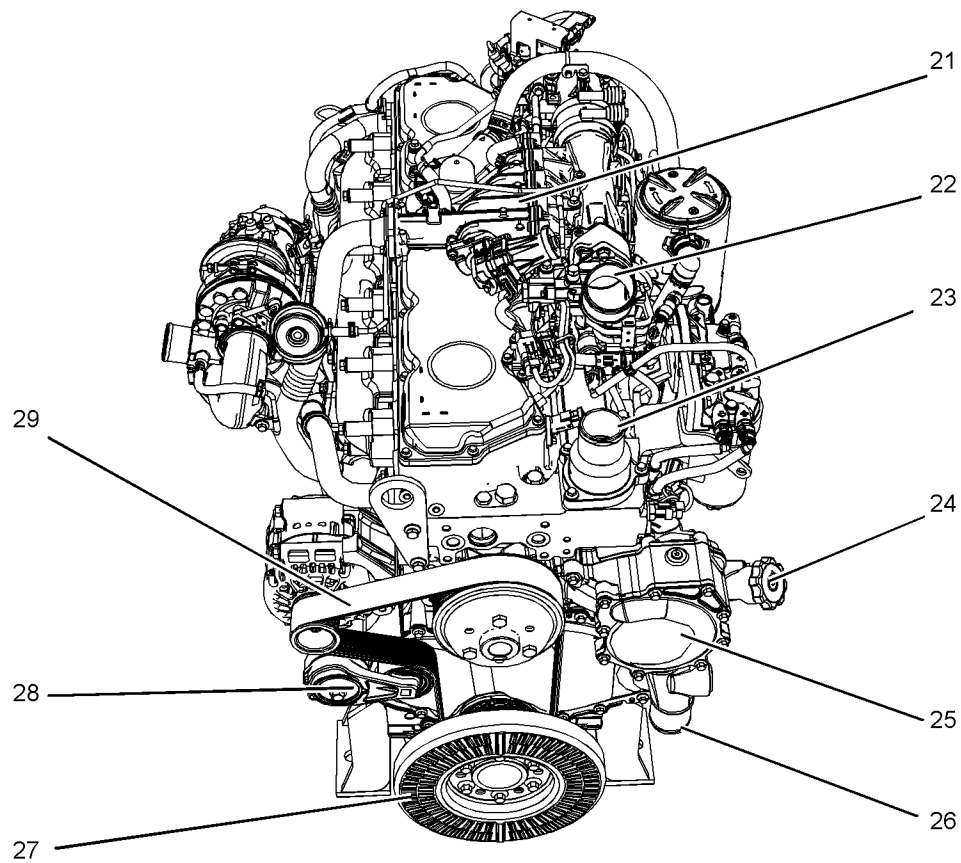

Illustration 18

g03387667

Typical example

(21) NOx Reduction system (NRS)
(22) Air intake
(23) Coolant outlet

(24) Oil filler cap
(25) Water pump
(26) Coolant intake

(27) Crankshaft damper
(28) Belt tensioner
(29) Belt

Off Engine Components

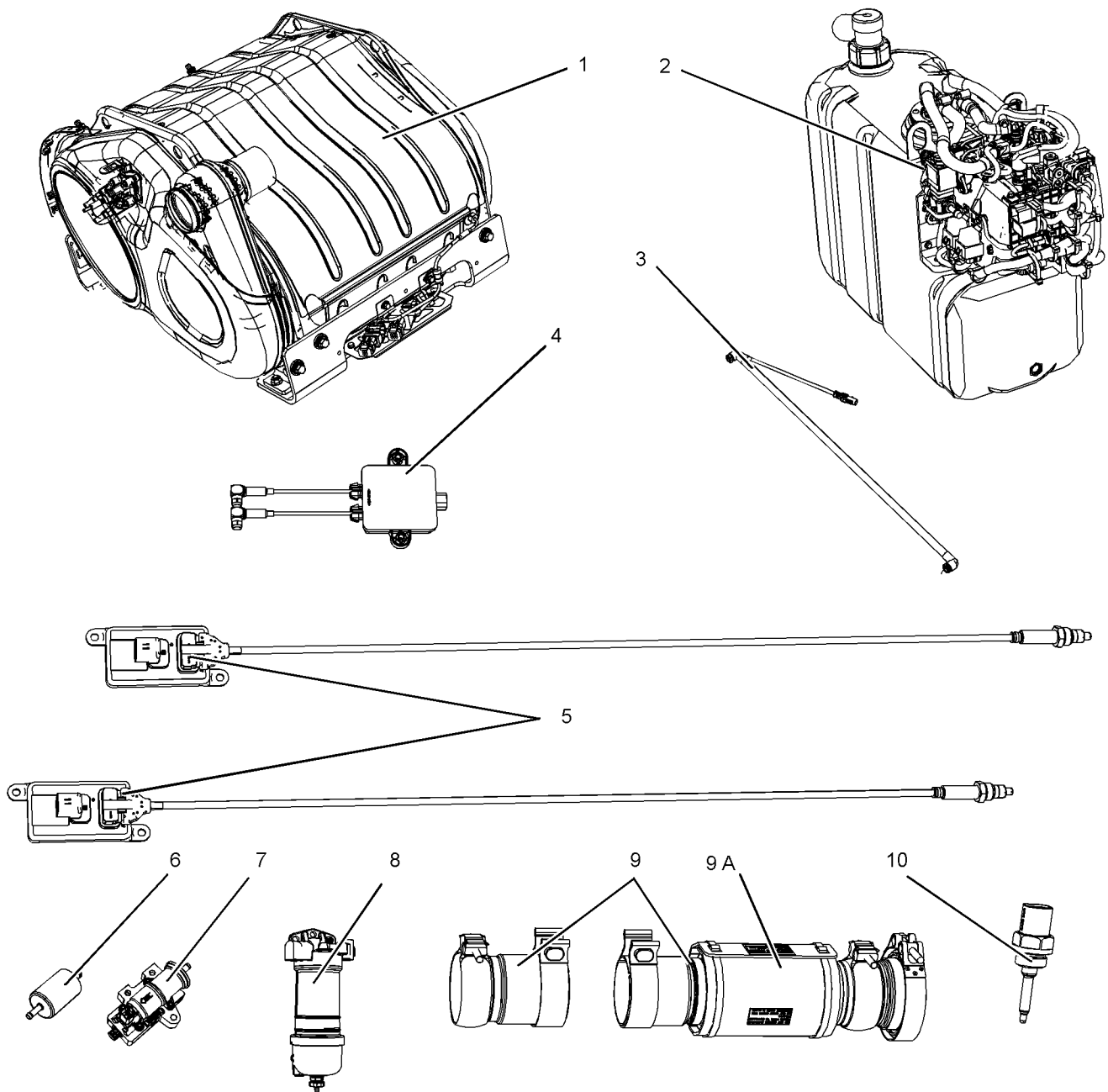

Illustration 19

g03387619

Items that can be supplied loose.

- | | | |
|--------------------------------|--------------------------------|---|
| (1) Clean emission module | (5) NOx sensors | (9) Flexible exhaust pipe assembly |
| (2) Pump electronics tank unit | (6) In-line fuel filter | (9 A) Protection sleeve for flexible exhaust pipe |
| (3) Heated line | (7) Priming/transfer fuel pump | (10) Inlet air temperature sensor |
| (4) Soot sensor control | (8) Primary fuel filter | |

Note: Use the sleeve (9 A) for transportation only.

Engine Aftertreatment System

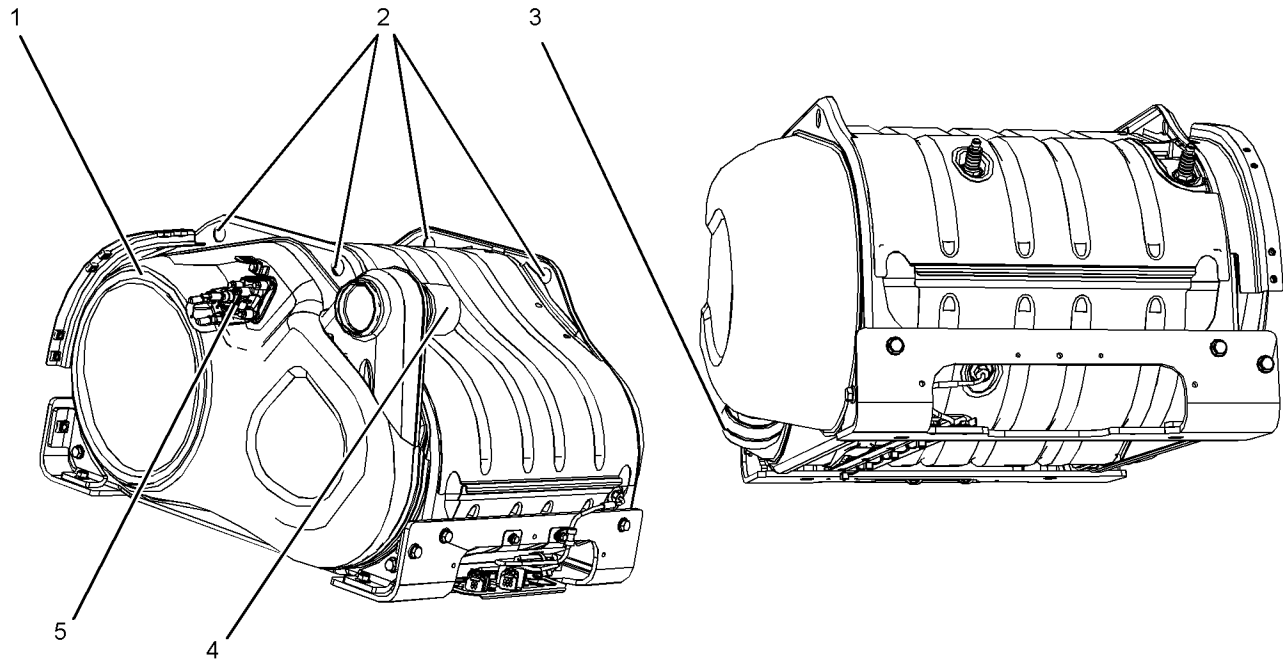

Illustration 20

g03027726

Typical example

(1) Clean Emission Module (CEM)
(2) Lifting eyes for CEM

(3) Exhaust intake connection
(4) Exhaust outlet connection

(5) Diesel Exhaust Fluid (DEF) injector

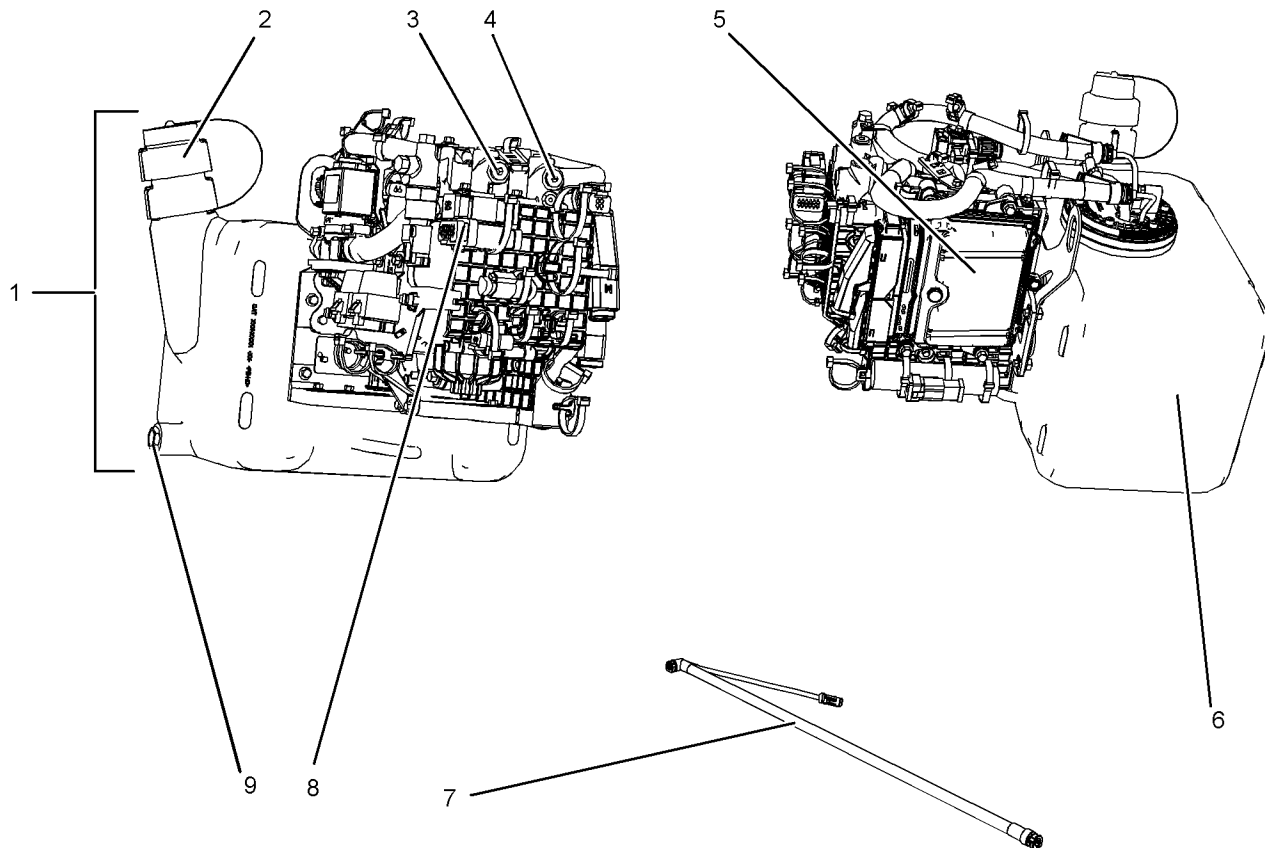

Illustration 21

g03034176

Typical example

- | | | |
|--|---------------------------------|-------------------------|
| (1) Pump Electronics Tank Unit (PETU) | (4) Coolant outlet | (7) Heated DEF line |
| (2) Diesel Exhaust Fluid (DEF) tank filler cap | (5) Dosing Control Module (DCU) | (8) Harness connections |
| (3) Coolant inlet | (6) DEF Tank | (9) DEF drain plug |

The size of the DEF tank will depend on the application. For more information on the aftertreatment system, refer to this Operation and Maintenance Manual, "Sensors and Electrical Components".

i05352909

Product Description (Engine and Aftertreatment)

SMCS Code: 1000; 4450; 4491

There are two variants of the C7.1 industrial engine the single turbocharged engine and the series turbocharged engine.

The Caterpillar C7.1 Industrial Engine has the following characteristics.

- In-line Six cylinder
- Four stroke cycle
- Four valves in each cylinder
- Series turbocharged charge cooled/or Single turbocharged charge cooled
- Aftertreatment System

The Clean Emissions Module (CEM) is constructed of three main items, the diesel oxidation catalyst, the diesel particulate filter, and the Selective Catalytic Reduction (SCR). The SCR requires the use of Diesel Exhaust Fluid (DEF) to be injected into the system in order to lower the emissions from the engine. The (DEF) is stored and controlled by the pump electronic tank unit. The DEF tank can be installed separate from the electronic pump unit.

Engine Specifications

Note: The front end of the engine is opposite the flywheel end of the engine. The left and the right sides of the engine are determined from the flywheel end. The number 1 cylinder is the front cylinder.

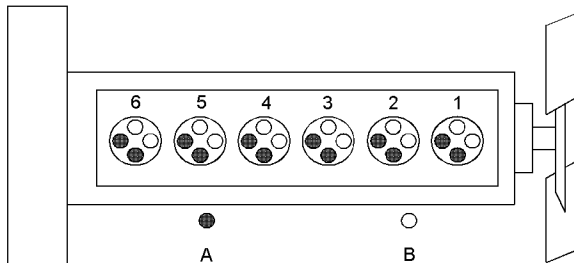

Illustration 22

g01127295

Cylinder and valve location

- (A) Exhaust valves
(B) Inlet valves

Table 1

C7.1 Single Turbocharged Engine Specifications	
Operating Range (rpm)	800 to 2500 ⁽¹⁾
Number of Cylinders	6 In-Line
Bore	105 mm (4.13 inch)
Stroke	127 mm (5 inch)
Power	116 to 151 kW (155.5 to 202.5 hp)
Aspiration	Turbocharged charge cooled
Compression Ratio	16.4:1
Displacement	7.01 L (428 in ³)
Firing Order	1-5-3-6-2-4
Rotation (flywheel end)	Counterclockwise

⁽¹⁾ The operating rpm is dependent on the engine rating, the application, and the configuration of the throttle.

Table 2

C7.1 Series Turbocharged Engine Specifications	
Operating Range (rpm)	800 to 2500 ⁽¹⁾
Number of Cylinders	6 In-Line
Bore	105 mm (4.13 inch)
Stroke	135 mm (5.31495 inch)

(continued)

(Table 2, contd)

Power	151 to 205 kW (202.5 to 274.9 hp)
Aspiration	Turbocharged charge cooled
Compression Ratio	16.4:1
Displacement	7.01 L (428 in ³)
Firing Order	1-5-3-6-2-4
Rotation (flywheel end)	Counterclockwise

⁽¹⁾ The operating rpm is dependent on the engine rating, the application, and the configuration of the throttle.

Electronic Engine Features

The engine and aftertreatment operating conditions are monitored. The Electronic Control Module (ECM) controls the response of the engine to these conditions and to the demands of the operator. These conditions and operator demands determine the precise control of fuel injection by the ECM. The electronic engine control system provides the following features:

- Engine monitoring
- Engine speed governing
- Control of the injection pressure
- Cold start strategy
- Automatic air/fuel ratio control
- Torque rise shaping
- Injection timing control
- System diagnostics
- NOx reduction system control
- Aftertreatment system control

The ECM provides an electronic governor that controls the injector output in order to maintain the desired engine rpm.

For more information on electronic engine features, refer to the Operation and Maintenance Manual, "Features and Controls" topic (Operation Section).

Engine Diagnostics

The engine has built-in diagnostics in order to ensure that the engine systems are functioning correctly. The operator will be alerted to the condition by a "Stop or Warning" lamp. Under certain conditions, the engine horsepower and the vehicle speed may be limited. The electronic service tool may be used to display the diagnostic codes.

There are three types of diagnostic codes: active, logged and event.

Most of the diagnostic codes are logged and stored in the ECM. For additional information, refer to the Operation and Maintenance Manual, "Engine Diagnostics" topic (Operation Section).

Engine Cooling and Lubrication

The cooling system and lubrication system consists of the following components:

- Gear-driven centrifugal water pump
- Water temperature regulator which regulates the engine coolant temperature
- Gear-driven gerotor type oil pump
- Oil cooler

The engine lubricating oil is supplied by a gerotor type oil pump. The engine lubricating oil is cooled and the engine lubricating oil is filtered. The bypass valve can provide unrestricted flow of lubrication oil to the engine if the oil filter element should become plugged.

Engine efficiency, efficiency of emission controls, and engine performance depend on adherence to proper operation and maintenance recommendations. Engine performance and efficiency also depend on the use of recommended fuels, lubrication oils, and coolants. Refer to this Operation and Maintenance Manual, "Maintenance Interval Schedule" for more information on maintenance items.

Engine Service Life

Engine efficiency and maximum utilization of engine performance depend on the adherence to proper operation and maintenance recommendations. In addition, use recommended fuels, coolants, and lubricants. Use the Operation and Maintenance Manual as a guide for required engine maintenance.

Expected engine life is generally predicted by the average power that is demanded. The average power that is demanded is based on fuel consumption of the engine over time. Reduced hours of operation at full throttle and/or operating at reduced throttle settings result in a lower average power demand. Reduced hours of operation will increase the length of operating time before an engine overhaul is required. For more information, refer to the Operation and Maintenance Manual, "Overhaul Considerations" topic (Maintenance Section).

Aftermarket Products and Caterpillar Engines

Caterpillar does not warrant the quality or performance of non-Caterpillar fluids and filters.

When auxiliary devices, accessories, or consumables (filters, additives, catalysts,) which are made by other manufacturers are used on Caterpillar products, the Caterpillar warranty is not affected simply because of such use.

However, failures that result from the installation or use of other manufacturers devices, accessories, or consumables are NOT Caterpillar defects. Therefore, the defects are NOT covered under the Caterpillar warranty.

Aftertreatment System

The aftertreatment system is approved for use by Caterpillar. In order to be emission-compliant only the approved Caterpillar aftertreatment system must be used on a Caterpillar engine.

Product Identification Information

i04897160

Plate Locations and Film Locations

SMCS Code: 1000; 4450

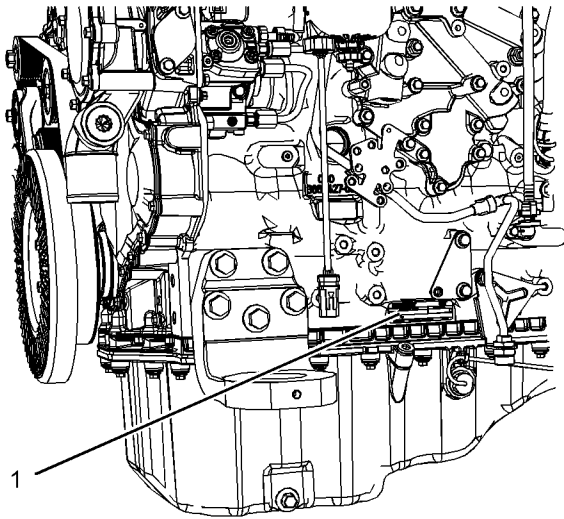

Illustration 23

g03046077

(1) Location of the engine serial number plate

Serial Number Plate

The engine serial number plate (1) is located on the left side of the cylinder block to the rear of the front engine mounting.

Caterpillar dealers need all of these numbers in order to determine the components that were included with the engine. The full serial number permits accurate identification of replacement part numbers.

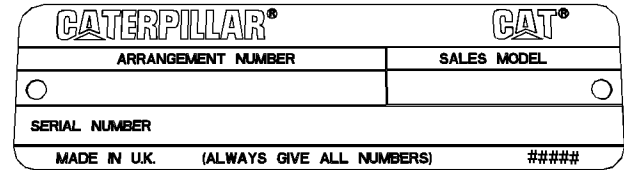

Illustration 24

g03047463

Typical example

i05349518

Plate Locations and Film Locations (Aftertreatment System)

SMCS Code: 1000; 4450

Clean Emission Module (CEM)

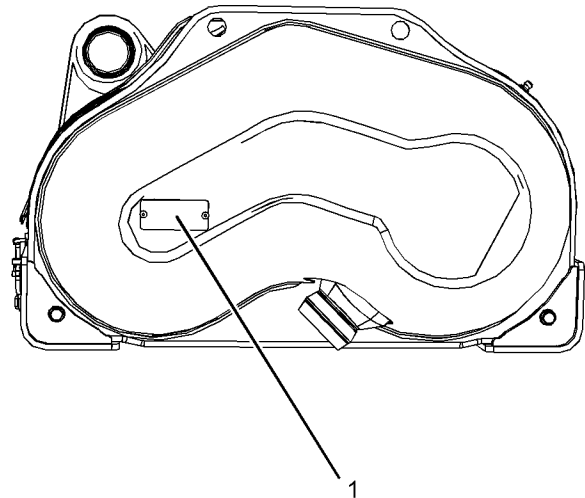

Illustration 25

g03047499

Typical example

The identification plate (1) is located on the intake end of the CEM.

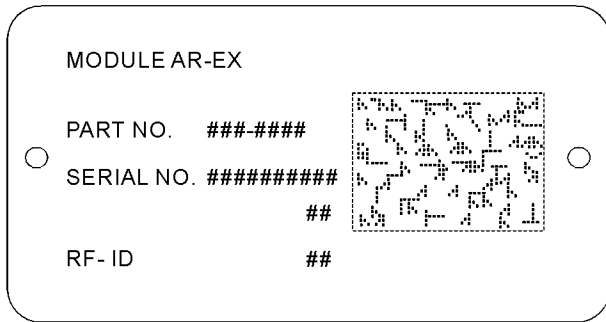

Illustration 26 g03388367
Typical example CEM identification plate

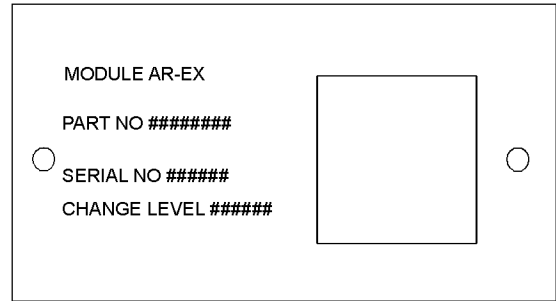

Illustration 28 g03418749
Typical example PETU serial plate

Pump Electronic Tank Unit (PETU)

Record all the information on the CEM and PETU serial plates. The information will be required by your Cat dealer in order to identify replacement part numbers.

i04274710

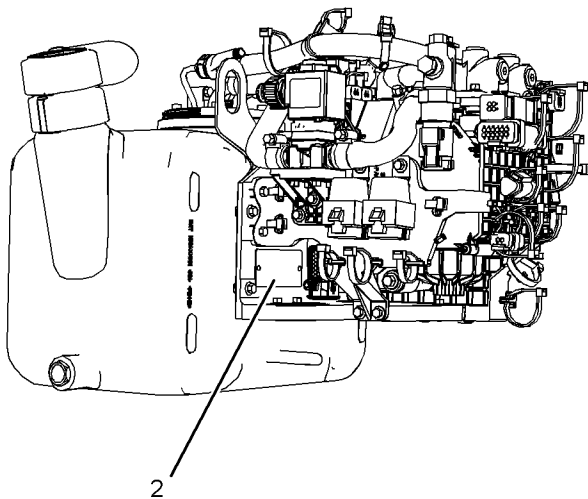

Illustration 27 g03419905
Typical example

The location of the PETU serial plate (2).



Emissions Certification Film

SMCS Code: 1000; 7405

The label for the emission is installed on the front gear cover.

Note: A second emission label will be supplied with the engine. If necessary, the second emission label will be installed on the application by the original equipment manufacturer.

Product Identification Information
Reference Information

EMISSION CONTROL INFORMATION		
 Manufactured by Perkins Engine Company Ltd.		
Engine family:	#####13#####	
Displacement:	#4##	
EPA/California Family:	#####12#####	
EPA/California Family Max. Values		
Fuel rate:	##5## mm3/Stk	
Initial timing:	#3# DEG ATDC	
THIS ENGINE COMPLIES WITH U.S. EPA REGULATIONS FOR #### NONROAD AND STATIONARY DIESEL ENGINES AND CALIFORNIA OFF-ROAD DIESEL ENGINES		
ULTRA LOW SULFUR FUEL ONLY		
Engine Type		
Power Category #3#<kW<#3#	Factory Set	Reset if Applicable
FEL (g/kWh)	<input type="checkbox"/>	####9#### #3kW <input type="checkbox"/>
NMHC + NOx: #4##	<input type="checkbox"/>	####9#### #3kW <input type="checkbox"/>
PM: ##5##	<input type="checkbox"/>	####9#### #3kW <input type="checkbox"/>
Emission Control System	<input type="checkbox"/>	####9#### #3kW <input type="checkbox"/>
#3# #3# #3# #3# #3# #3#	Use service tool to verify current engine settings	
Argt. No. ###8####	Serial No. ###8####	Label No. ###-####
<input type="text"/>		
 120 R - ##6###		
#####28#####		
MLIT #####20#####		
Date of Manufacture: #3# #4##		

Secondary Fuel Filter Element_____

Lubrication Oil Filter Element_____

Auxiliary Oil Filter Element_____

Total Lubrication System Capacity_____

Total Cooling System Capacity_____

Air Cleaner Element_____

Drive Belt_____

Clean Emission Module

Part Number_____

Serial Number_____

Pump Electronics Tank Unit

Part Number_____

Serial Number_____

Illustration 29

g02443539

Typical example

i05362542

Reference Information

SMCS Code: 1000; 4450

Information for the following items may be needed to order parts. Locate the information for your engine. Record the information in the appropriate space. Make a copy of this list for a record. Keep the information for future reference.

Record for Reference

Engine Model_____

Engine Serial number_____

Engine Low Idle rpm_____

Engine Full Load rpm_____

In Line Fuel Filter_____

Primary Fuel Filter_____

Operation Section

Lifting and Storage

i05350494

Product Lifting

SMCS Code: 7000; 7002

NOTICE

Never bend the eyebolts and the brackets. Only load the eyebolts and the brackets under tension. Remember that the capacity of an eyebolt is less as the angle between the supporting members and the object becomes less than 90 degrees.

When it is necessary to remove a component at an angle, only use a link bracket that is properly rated for the weight.

Read all the information within produce lifting before any lifting is attempted. Ensure that the correct set of lifting eyes for the assembly to be lifted have been selected.

Use a hoist to remove heavy components. Use an adjustable lifting beam to lift the assembly. All supporting members (chains and cables) should be parallel to each other. The chains and cables should be perpendicular to the top of the object that is being lifted.

Engine and Clean Emission Module (CEM)

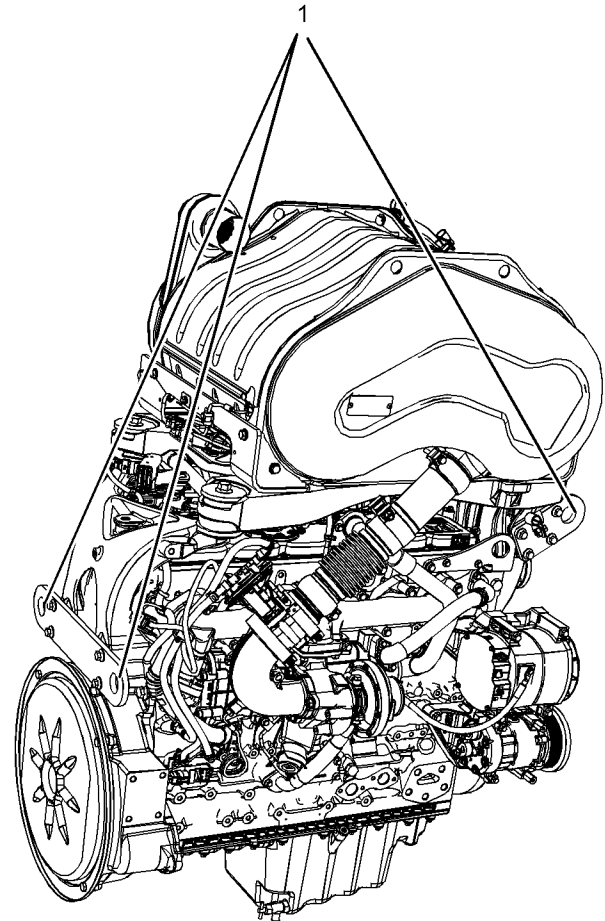

Illustration 30

g03051657

Typical example

(1) Lifting eyes for engine and aftertreatment.

Refer to illustration 30 for the location of the lifting eyes in order to lift the assembly.

CEM Only

Ensure that the exhaust inlet for the CEM is not damaged during removal and installation. Do not allow the weight of the CEM to act on the exhaust inlet.

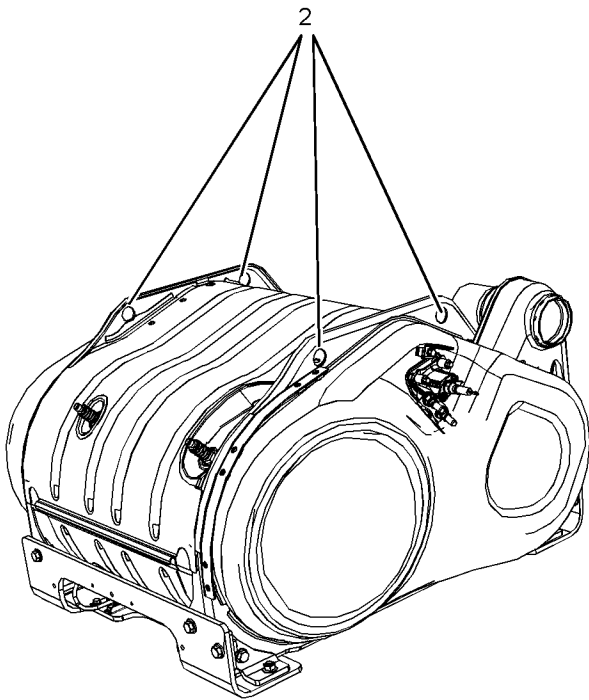

Illustration 31

g03051677

Typical example

(2) Lifting eyes for the CEM

Refer to illustration 31 for the location of the lifting eyes in order to lift the CEM. The lifting eyes (2) are designed only to lift the CEM. The lifting eyes (2) must not be used to lift any other parts of the application.

Note: If the CEM is removed from the application, the inlet and outlet connections must be protected in order to prevent damage.

Pump Electronics Tank Unit (PETU) Only

The tank on the PETU should be empty before the assembly is lifted.

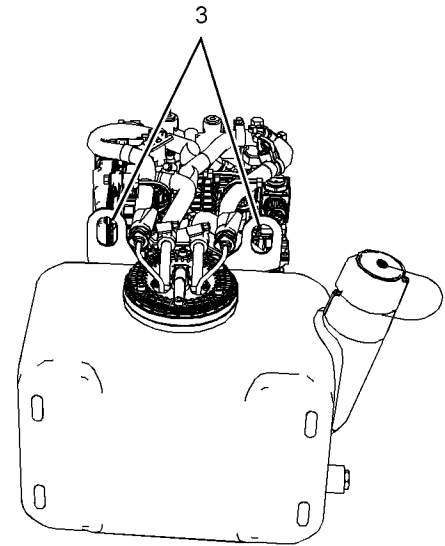

Illustration 32

g03419909

Typical example

(3) Lifting eyes for PETU

Refer to illustration 32 for the location of the lifting eyes in order to lift the PETU.

Engine Only

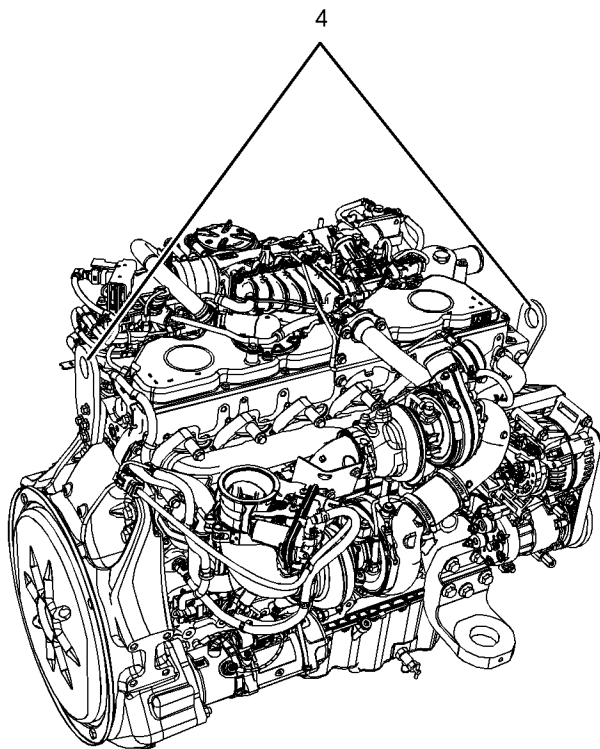

Illustration 33

g03051679

Typical example

(4) Lifting eyes for the engine

Refer to illustration 32 for the location of the lifting eyes in order to lift the engine.

i05359242

Product Storage

SMCS Code: 7002

If the engine will not be started for several weeks, the lubricating oil will drain from the cylinder walls and from the piston rings. Rust can form on the cylinder liner surface. Rust on the cylinder liner surface will cause increased engine wear and a reduction in engine service life.

To help prevent excessive engine wear, use the following guidelines:

- Complete all of the lubrication recommendations that are listed in this Operation and Maintenance Manual, “Maintenance Interval Schedule” (Maintenance Section).
- If freezing temperatures are expected, check the cooling system for adequate protection against freezing. See this Operation and Maintenance Manual, “Refill Capacities and Recommendations” (Maintenance Section).

If an engine is out of operation and if use of the engine is not planned, special precautions should be made. If the engine will be stored for more than 1 month, a complete protection procedure is recommended.

Ensure that the outlets on the Clean Emission Module (CEM) are capped. Ensure that the Diesel Exhaust Fluid (DEF) injector connections are capped.

In order to prevent damage to the exhaust outlet connection during storage, the weight of the CEM must not act on the exhaust outlet.

For more detailed information on engine storage, see Special Instruction, SEHS9031, “Storage Procedure For Caterpillar Products”.

Your Cat dealer can assist in preparing the engine for extended storage periods.

Aftertreatment

The engine must be allowed to perform a DEF purge before the battery disconnect switch is turned off. Some applications, the engine can be equipped with delayed engine shutdown. Allow 2 minutes after the engine has stopped before disconnecting the battery disconnect switch.

The exhaust outlet of the aftertreatment must be capped. In order to prevent damage to the exhaust outlet connection during storage, the weight of the CEM must not act on the exhaust outlet.

DEF Tank Storage

1. Ensure normal engine shutdown, allow the DEF to be purged. Do not disconnect the battery disconnect switch, allow 2 minutes after key off before disconnection.
2. Fill the tank with DEF that meet all the requirement defined in ISO 22241-1.
3. Ensure that all DEF lines and electrical connection are connected prior to prevent crystal from forming.
4. Ensure that the DEF filler cap is correctly installed.

Removal from Storage

DEF has a limited life, refer to table 3 for the time and temperature range. DEF that is outside this range MUST be replaced.

On removal from storage the DEF quality in the tank must be tested with a refractometer. The DEF in the tank must meet the requirements defined in ISO 22241-1 and comply with table 3 .

1. If necessary, drain the tank and fill with DEF that meet ISO 22241-1.
2. Replace the DEF filter, refer to this Operation and Maintenance Manual, “Diesel Exhaust Fluid Filter-Clean/Replace”.
3. Ensure that the drive belt is correctly installed. Ensure that all engine coolant and engine oil has the correct specification and grade. Ensure that the coolant and the engine oil are at the correct level. Start the engine. If a fault becomes active turn off the engine, allow 2 minutes for the DEF system to purge, then restart the engine.
4. If the fault continues to stay active, refer to Troubleshooting for more information.

Table 3

Temperature	Duration
10° C (50° F)	36 months
25° C (77° F)	18 months
30° C (86° F)	12 months
35° C (95° F) ⁽¹⁾	6 months

⁽¹⁾ At 35° C, significant degradation can occur. Check every batch before use.

Features and Controls

i05416516

Alarms and Shutoffs

SMCS Code: 7400

Shutoffs

The shutoffs are electrically operated or mechanically operated. The electrically operated shutoffs are controlled by the ECM.

Shutoffs are set at critical levels for the following items:

- Operating temperature
- Operating pressure
- Operating level
- Operating rpm

The particular shutoff may need to be reset before the engine will start.

NOTICE

Always determine the cause of the engine shutdown. Make necessary repairs before attempting to restart the engine.

Be familiar with the following items:

- Types and locations of shutoff
- Conditions which cause each shutoff to function
- The resetting procedure that is required to restart the engine

Alarms

The alarms are electrically operated. The operations of the alarms are controlled by the ECM.

The alarm is operated by a sensor or by a switch. When the sensor or the switch is activated, a signal is sent to the ECM. An event code is created by the ECM. The ECM will send a signal in order to illuminate the lamp.

Your engine may be equipped with the following sensors or switches:

Coolant temperature – The coolant temperature sensor indicates high jacket water coolant temperature.

Intake manifold air temperature – The intake manifold air temperature sensor indicates high intake air temperature.

Intake manifold pressure – The intake manifold pressure sensor checks the rated pressure in the engine manifold.

Fuel rail pressure – The fuel rail pressure sensor measures the high pressure or low pressure in the fuel rail. The ECM will Check the pressure.

Engine oil pressure – The engine oil pressure sensor indicates when oil pressure drops below rated system pressure, at a set engine speed.

Engine overspeed – If, the engine rpm exceeds the overspeed setting the alarm will be activated.

Air filter restriction – The switch checks the air filter when the engine is operating.

User-defined switch – This switch can shut down the engine remotely.

Water in fuel switch – This switch checks for water in the primary fuel filter when the engine is operating.

Fuel temperature – The fuel temperature sensor monitors the pressurized fuel in the high-pressure fuel pump.

Note: The sensing element of the coolant temperature switch must be submerged in coolant in order to operate.

Engines may be equipped with alarms in order to alert the operator when undesirable operating conditions occur.

NOTICE

When an alarm is activated, corrective measures must be taken before the situation becomes an emergency in order to avoid possible engine damage.

If corrective measures are not taken within a reasonable time, engine damage could result. The alarm will continue until the condition is corrected. The alarm may need to be reset.

Note: If installed, the coolant level switch and the oil level switch are indicators. Both switches operate when the application is on level ground and the engine RPM at zero.

Clean Emission Module (CEM)

- Diesel Oxidation Catalyst _____(DOC)
- Selective Catalyst Reduction _____ (SCR)

Soot Sensors – The soot sensors monitor the soot level within the CEM

NOx Sensors – Two NOx sensors monitor the NOx concentration within the exhaust gas before and after the selective catalyst reduction module.

Temperature Sensors – A temperature sensor after the engine exhaust gas exit, after the DOC and

before the SCR module monitor the temperatures within the system.

Pump Electronics Tank Unit (PETU) Alarms and Shutoff

Diesel Exhaust Fluid (DEF) Level Sensor – The DEF level sensor monitors the volume of fluid in the tank and signals the ECM if the level drops below a given point.

Dosing Control Unit (DCU) – The DCU controls the injection of the DEF and will signal the ECM if the injection has been interrupted.

Testing

Turning the keyswitch to the ON position will check the indicator lights on the control panel. All the indicator lights will be illuminated for 2 seconds after the keyswitch is operated. Replace suspect bulbs immediately.

Refer to Troubleshooting for more information.

i05406889

Selective Catalytic Reduction Warning System

SMCS Code: 1091-WXX; 7400

The Selective Catalytic Reduction (SCR) system is a system used to reduce NOx emissions from the engine. Diesel Exhaust Fluid (DEF) is pumped from the DEF tank and is sprayed into the exhaust stream. The DEF reacts with the SCR catalyst to reduce NOx and leaves a nitrogen and water vapor.

NOTICE

Stopping the engine immediately after the engine has been working under load can result in overheating of DEF system components.

Refer to the Operation and Maintenance Manual, “Engine Stopping” procedure to allow the engine to cool and to prevent excessive temperatures in the turbo-charger housing and the DEF injector.

NOTICE

Allow at least 2 minutes after the engine has stopped before you turn the battery disconnect switch to OFF. Disconnecting the battery power too soon will prevent purging of the DEF lines after the engine is shut down.

Warning Strategy

The Electronic Control Module (ECM) will have either a world-wide warning strategy or a European union warning strategy enabled within the ECM software.

The European union warning strategy is comprised of two different options. The two options will give different response times for the operated to act and different de-rates to the engine. Only one option will be enabled.

DEF Level Warning Strategy

The DEF level world-wide warning strategy and the DEF level European union warning strategy both offer two options. Only one option will be enabled. These warning strategy options will give different response times and different derate to the engine.

Warning Indicators

The warning indicators consist of a level gauge for the DEF, a low-level lamp for the DEF, an emission malfunction lamp, and the application stop lamp.

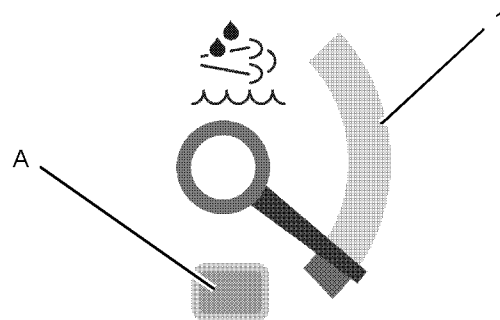

Illustration 34

g03069862

(1) DEF gauge
(A) Low-level warning lamp

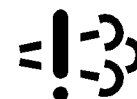

Illustration 35

g02852336

Emission malfunction lamp

Warning Levels

The SCR has three levels of warning. Depending on the fault that has been detected and software enabled will govern the time that the system will stay at each warning level.

Any warning should be investigated immediately, contact your Cat dealer. The system is equipped with an override option. Once the override option has been used and the fault still exist, the engine will be locked in de-rate or shutdown mode.

World-Wide SCR Warnings

- At Level 1 the emission malfunction lamp will be on solid.
- At Level 2 the emission malfunction lamp will flash.
- At Level 3 the emission malfunction lamp will flash and the stop lamp will activate.
- At Level 3 the engine may shut down or operate at 1000 Revolutions Per Minute (RPM).
- At Level 3 cycling the keyswitch will give 20 minutes override at full power, before the shutdown or idle is triggered. The emission malfunction lamp will continue to flash .If installed, an audible warning will sound.

Table 4

World-Wide					
DEF Quality Tampering and Dosing Interruption					
-	Normal operation	Level 1	Level 2	Level 3	Override
Inducement Time First occurrence	None	2.5 Hours	70 minutes	Shut down or idle Until fault heals	Cycling the keyswitch will give 20 minutes of full power
The system must be fault free for 40 hours before the system will reset to zero. If the fault is intermittent, and returns within the 40 hours, then the repeat inducement time will be triggered. The override can only be used once					
Repeat Inducement time	None	5 minutes	5 minutes	Shut down or idle Until fault heals	Cycling the keyswitch will give 20 minutes of full power
Inducement	None	None	None		
Notification	None	Emission malfunction lamp will be on solid	Emission malfunction lamp will flash	Emission malfunction lamp will flash The stop lamp will be on solid	Emission malfunction lamp will flash
Contact your Cat dealer at level 1 warning, do not let the fault develop.					

Table 5

World-Wide					
NOx Reduction System Fault					
-	Normal operation	Level 1	Level 2	Level 3	Override
Inducement Time First occurrence	None	35 Hours	60 minutes	Shut down or idle Until fault heals	Cycling the keyswitch will give 20 minutes of full power

(continued)

Features and Controls

Selective Catalytic Reduction Warning System

(Table 5, contd)

The system must be fault free for 40 hours before the system will reset to zero. If the fault is intermittent, and returns within the 40 hours, then the repeat inducement time will be triggered. The override can only be used once.					
Repeat Inducement time	None	48 minutes	60 minutes	Shut down or idle Until fault heals	Cycling the keyswitch will give 20 minutes of full power
Inducement	None	None	None		
Notification	None	Emission malfunction lamp will be on solid	Emission malfunction lamp will flash	Emission malfunction lamp will flash The stop lamp will activate	Emission malfunction lamp will flash
Contact your Cat dealer at level 1 warning, do not let the fault develop.					

World-Wide DEF Level Warnings

Two options are available but only one option will be enabled.

- The low-level warning lamp will operate when DEF level reaches the trigger point of below 19 percent.
- At Level 1 the low-level warning lamp in the DEF gauge will illuminate and the emission malfunction lamp will be on solid.
- At Level 2 the low-level warning lamp for the DEF is active and the emission malfunction lamp will flash.
- At Level 3 all level 2 warning are operating, plus the stop lamp will become activate. The engine will shut down or will only operate at 1000 RPM. If installed, an audible warning will sound.

Filling the DEF tank will remove the warning from the system.

Table 6

World-Wide DEF Level Option 1					
-	Normal operation	Initial indication	Level 1	Level 2	Level 3
Inducement Trigger	Above 19 percent	Below 19 percent	Below 12.5 percent	0 Percent reading	Empty tank
Inducement	None	None	None	25 percent torque de-rate	Shut down or idle only
Notification	None	Low-level lamp illuminated	Low-level lamp illuminated Emission malfunction lamp on solid	Low-level lamp illuminated Emission malfunction lamp flashing	Low-level lamp illuminated Emission malfunction lamp flashing Stop lamp on solid

Table 7

World-Wide DEF Level Option 2					
-	Normal operation	Initial indication	Level 1	Level 2	Level 3
Inducement Trigger	Above 19 percent	Below 19 percent	Below 12.5 percent	6 Percent reading	0 Percent reading

(continued)

(Table 7, contd)

Inducement	None	None	None	None	Shut down or idle only
Notification	None	Low-level lamp illuminated	Low-level lamp illuminated Emission malfunction lamp on solid	Low-level lamp illuminated Emission malfunction lamp flashing	Low-level lamp illuminated Emission malfunction lamp flashing Stop lamp on solid

i05408886

Battery Disconnect Switch (If Equipped)

SMCS Code: 1411

Allow at least 2 minutes after the engine has stopped before you turn the battery disconnect switch to OFF. Disconnecting the battery power too soon will prevent purging of the Diesel Exhaust Fluid (DEF) lines after the engine is shut down. Also, during the 2 minutes the engine Electronic Control Module (ECM) is active storing information from the engine and aftertreatment sensors.

Not allowing the DEF purge to be performed can damage the DEF system. Not allowing the engine ECM time to store the information from the sensors can damage to emission control system.

Some applications, the engine can be equipped with a wait to disconnect lamp. The wait to disconnect lamp will be illuminated during engine operation and will be extinguished approximately 2 minutes after the engine has stopped.

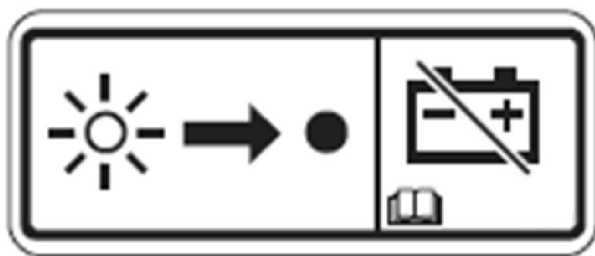

Illustration 36

g03265058

Battery disconnect switch label

NOTICE

Do not turn off the battery disconnect switch until the indicator lamp has turned off. If the switch is turned off when the indicator lamp is illuminated the Diesel Exhaust Fluid (DEF) system will not purge the DEF. If the DEF does not purge, DEF could freeze and damage the pump and lines.

NOTICE

Never move the battery disconnect switch to the OFF position while the engine is operating. Serious damage to the electrical system could result.

i05353501

Gauges and Indicators

SMCS Code: 7450

Your engine may not have the same gauges or all of the gauges that are described. For more information about the gauge package, see the OEM information.

Gauges provide indications of engine performance. Ensure that the gauges are in good working order. Determine the normal operating range by observing the gauges over a period.

Noticeable changes in gauge readings indicate potential gauge or engine problems. Problems may also be indicated by gauge readings that change even if the readings are within specifications. Determine and correct the cause of any significant change in the readings. Consult your Cat dealer for assistance.

Some engine applications are equipped with Indicator Lamps. Indicator lamps can be used as a diagnostic aid. There are two lamps. One lamp has an orange lens and the other lamp has a red lens.

These indicator lamps can be used in two ways:

- The indicator lamps can be used to identify the current operational status of the engine. The indicator lamps can also indicate that the engine has a fault. This system is automatically operated via the ignition switch.
- The indicator lamps can be used to identify active diagnostic codes. This system is activated by pressing the Flash Code button.

Refer to the Troubleshooting Guide, "Indicator Lamps" for further information.

NOTICE

If no oil pressure is indicated, STOP the engine. If maximum coolant temperature is exceeded, STOP the engine. Engine damage can result.



Engine Oil Pressure – The oil pressure should be greatest after a cold engine is started. The typical engine oil pressure with SAE10W40 is 350 to 450 kPa (50 to 65 psi) at rated rpm.

A lower oil pressure is normal at low idle. If the engine speed and load are stable and the gauge reading changes, perform the following procedure:

1. Remove the load.
2. Stop the engine.
3. Check and maintain the oil level.



Jacket Water Coolant Temperature – Typical temperature range is 82° to 94°C (179.6° to 169.2°F). This temperature range will vary according to engine load and the ambient temperature.

A 100 kPa (14.5 psi) radiator cap must be installed on the cooling system. The maximum temperature for the cooling system is 108° C (226.4° F). This temperature is measured at the outlet for the water temperature regulator. The engine coolant temperature is regulated by the engine sensors and the engine ECM. This programming cannot be altered. Derates can occur if the maximum engine coolant temperature is exceeded.

If the engine is operating above the normal range, reduce the engine load. If high coolant temperatures are a frequent event, perform the following procedures:

1. Reduce the load on the engine.
2. Determine if the engine must be shut down immediately or if the engine can be cooled by reducing the load.
3. Inspect the cooling system for leaks. If necessary, consult your Caterpillar dealer for assistance.



Tachometer – This gauge indicates engine speed (rpm). When the throttle control lever is moved to the full throttle position without load, the engine is running at high idle. The engine is running at the full load rpm when the throttle control lever is at the full throttle position with maximum rated load.

NOTICE

To help prevent engine damage, never exceed the high idle rpm. Overspeeding can result in serious damage to the engine. Operation at speeds exceeding high idle rpm should be kept to a minimum.



Ammeter – This gauge indicates the amount of charge or discharge in the battery charging circuit. Operation of the indicator should be to the “+” side of “0” (zero).



Fuel Level – This gauge indicates the fuel level in the fuel tank. The fuel level gauge operates when the “START/STOP” switch is in the “on” position.



Service Hour Meter – The gauge indicates total operating hours of the engine.

Indicator Lamps

- Shutdown lamp
- Warning lamp
- Wait to start lamp (Glow plug warning lamp)
- Low oil pressure lamp

For information, refer to this manual, “Monitoring System (Table for the Indicator Lamps)” for the sequence of operation of the shutdown lamp and the warning lamp.

The function of the wait to start lamp is automatically controlled at engine start-up.

The function of the low oil pressure lamp is controlled by the engine ECM. If low oil pressure is detected, the lamp will be illuminated. The reason for the illumination of the low-pressure lamp should be investigated immediately.

All lamps will illuminate for 2 seconds in order to check that the lamps are functioning when the keyswitch is turned to the ON position. If any of the lamps stay illuminated, or a lamp fails to be illuminated the reason should be investigated immediately.

The glow plug warning lamp will flash in order to show that the engine is been held at low speed. This function will be performed at engine starting and the duration will depend on ambient temperature and engine temperature.

Aftertreatment Lamps and gauges

All applications will require the following lamps and gauges:

- Emission malfunction lamp
- Action indicator lamp
- Gauge for Diesel Exhaust Fluid (DEF)
- Low warning lamp for DEF
- Wait to disconnect lamp (optional)

The wait to disconnect lamp will be illuminated during engine operation and will be extinguished approximately 2 minutes after the engine has stopped. Do not disconnect the battery disconnect switch during the period the lamp is illuminated. The DEF system will be purged during this time. Also, during the 2 minutes the engine electronic control module is active storing information from the engine and aftertreatment sensors.

Note: The wait to disconnect lamp will not be checked at key on. The wait to disconnect lamp will illuminate at key on.

i04901303

Monitoring System (Engine Indicators and Aftertreatment Indicators)

SMCS Code: 1900; 7400; 7450; 7451

Engine Indicator Lamps

Note: When in operation the amber warning lamp has three states, solid, flashing, and fast flashing. The sequence is to give a visual indication of the importance of the warning. Some application can have an audible warning installed.

Ensure that the engine maintenance is carried out at the correct intervals. A lack of maintenance can result in illumination of the warning lamp. For the correct intervals of maintenance, refer to the Operation and Maintenance Manual, "Maintenance Interval Schedule".

Table 8

Indicator Lamp Table				
Warning Lamp	Shutdown Action Indicator Lamp	Lamp State	Description of the Indication	Engine Status
On	On	Lamp Check	When the keyswitch is moved to the ON position, the lamps come on for 2 seconds and the lamps will then go off.	The keyswitch is in the ON position but the engine has not yet been cranked.
If any of the indicators will not illuminate during indicator check, the fault must be investigated immediately If any Indicators stay illuminated or flash, the fault must be investigated immediately.				
Off	Off	No Faults	With the engine in operation, there are no active warnings, diagnostic codes, or event codes.	The engine is operating with no detected faults.
On Solid	Off	Warning	Level 1 warning	The engine is operating normally but there is one or more faults with the electronic management system for the engine.
As soon as possible the fault should be investigated.				

(continued)

Features and Controls

Overspeed

(Table 8, contd)

Indicator Lamp Table				
Warning Lamp	Shutdown Action Indicator Lamp	Lamp State	Description of the Indication	Engine Status
Flashing	Off	Warning	Level 2 warning	The engine continues to be operated, but the level of importance of the warning has increased. Depending on the particular fault and the severity the engine may be de-rated. The engine could be damaged if continued to be operated.
Stop the engine. Investigate the code.				
Flashing	On	Engine Shutdown	Level 3 warning If both the warning lamp and the shutdown lamp are in operation, this issue indicates one of the following conditions. 1. One or more of the shutdown values for the engine protection strategy has been exceeded. 2. A serious active diagnostic code has been detected. If install, the audible warning will sound. After a short time period, the engine may shut down.	The engine is either shutdown or an engine shutdown is imminent. One or more monitored engine parameters have exceeded the limit for an engine shutdown. This pattern of lamps can be caused by the detection of a serious active diagnostic code. Contact your Cat dealer.

Flash Codes

Some applications may support flash codes. A flash code can be viewed by an indicator lamp that when asked will flash in a particular sequence. The indicator lamp used to view the codes is the warning lamp, the lamp can then be refer to as a diagnostic lamp. For more information refer to this Operation and Maintenance Manual, "Diagnostic Lamp".

Aftertreatment System

The aftertreatment indicators should illuminate at key on for 2 seconds in order to test the system. If any of the indicators do not illuminate, the fault must be investigated immediately.

For more information on the illumination of the aftertreatment indicators refer to this Operation and Maintenance Manual, "Selective Catalytic Reduction Warning System".

i03554501

Overspeed

SMCS Code: 1900; 1907; 1912; 7427

- ECM _____ Electronic Control Module
- RPM _____ Revolutions Per Minute

An overspeed is detected by the speed/timing sensors.

The default setting for an overspeed is 3000 rpm. The ECM will cut the power to the electronic unit injectors, until the rpm drops below 200 rpm of the overspeed setting. A diagnostic fault code will be logged into the ECM memory and a warning lamp will indicate a diagnostic fault code.

An overspeed can be set from 2600 rpm to 3000 rpm. This setting depends on the application.

i05350563

Sensors and Electrical Components

SMCS Code: 1900; 7400

The illustrations within the following sections are typical location of the sensors or electrical components for an industrial engine. Specific engines may appear different due to differences in applications.

Engine Components

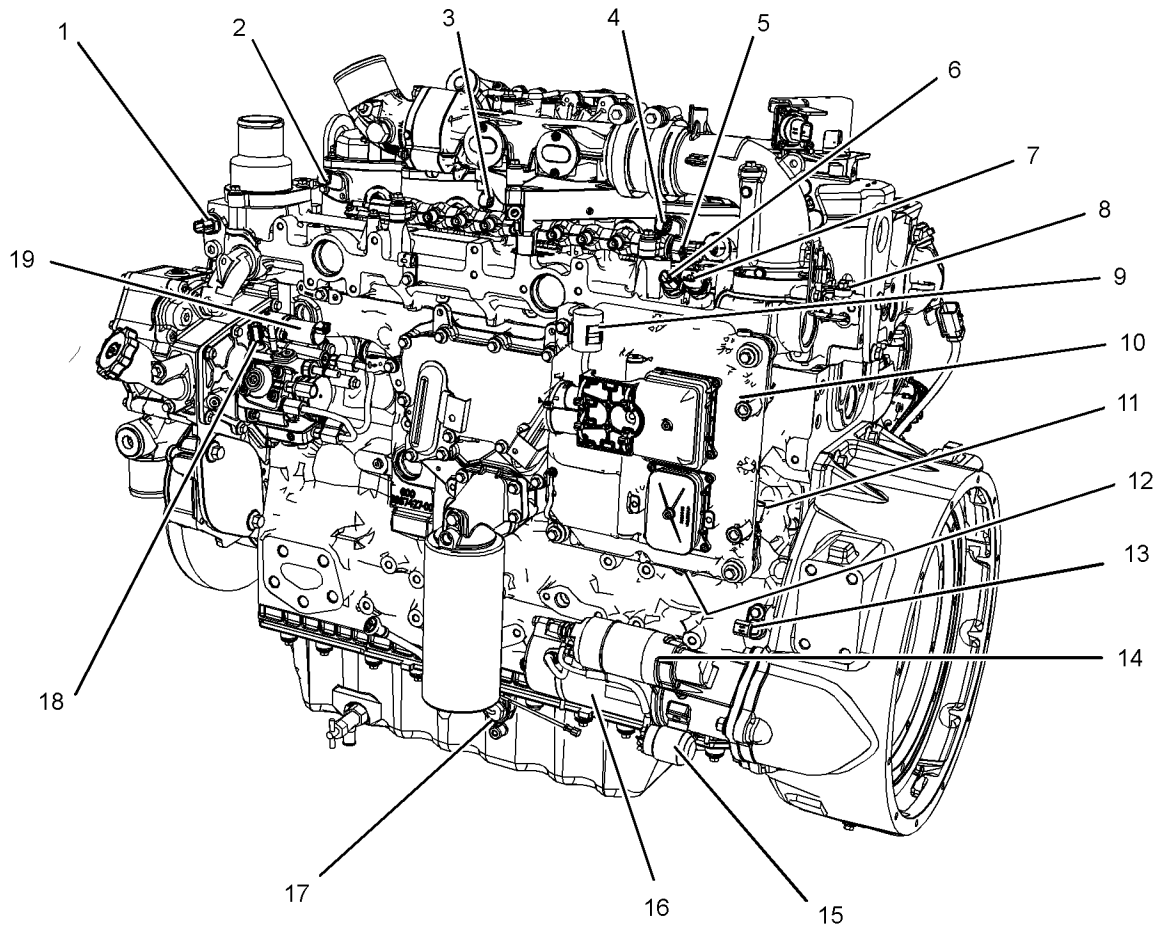

Illustration 37

g03389319

Typical example

- | | | |
|--|---|---|
| (1) Coolant Temperature Sensor | (6) Inlet Manifold Air Temperature Sensor | (13) Primary Speed/Timing Sensor |
| (2) Injector Connector for Number One and Two Injectors | (7) Inlet Manifold Air Pressure Sensor | (14) Starter Solenoid |
| (3) Injector Connector for Number three and Four Injectors | (8) Glow Plug Connection | (15) Starter relay |
| (4) Injector Connector for Number Five and Six Injectors | (9) Diagnostic Connector | (16) Starting Motor |
| (5) Fuel Pressure Sensor | (10) Electronic Control Module | (17) Oil Level Switch |
| | (11) Atmospheric Pressure Sensor (Barometric Pressure sensor) | (18) Fuel Temperature Sensor |
| | (12) Oil Pressure Sensor | (19) Solenoid for High Pressure Fuel Pump |

Features and Controls
Sensors and Electrical Components

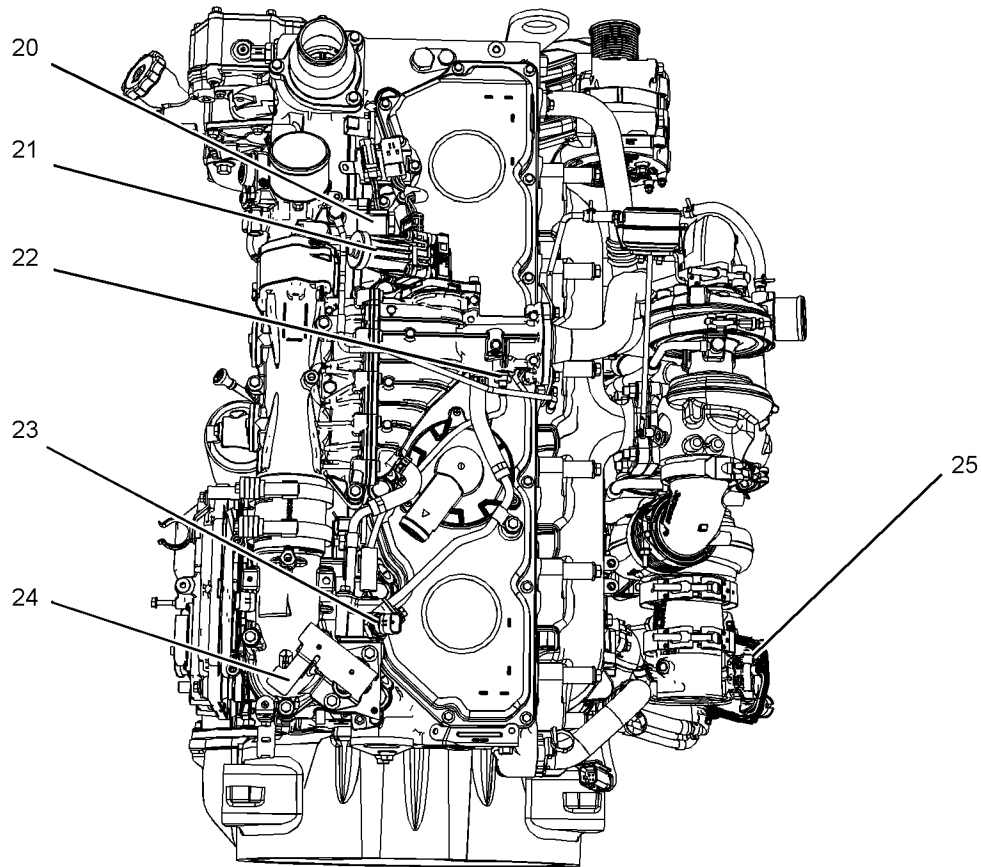

Illustration 38

g03389322

Typical example

(20) Wastegate Regulator
(21) Control Valve for the NO_x Reduction
System (NRS)

(22) Temperature Sensor for the NRS
(23) Intake Pressure for the NRS
(24) Differential Pressure for the NRS

(25) Back Pressure Valve

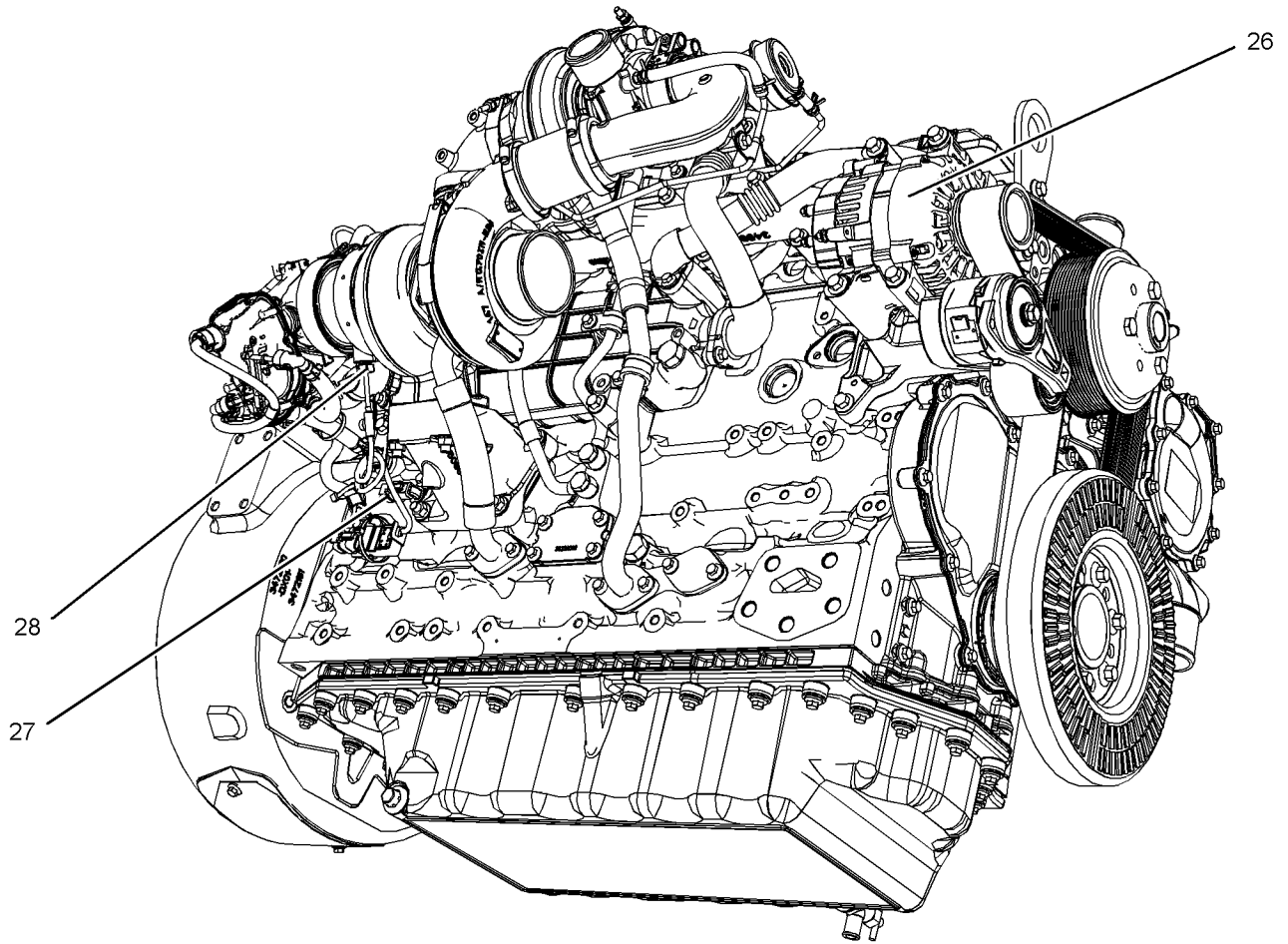

Illustration 39

Typical example

(26) Alternator

(27) Secondary Speed/Timing sensor

(28) Exhaust Temperature Sensor

g03389323

Features and Controls
Sensors and Electrical Components

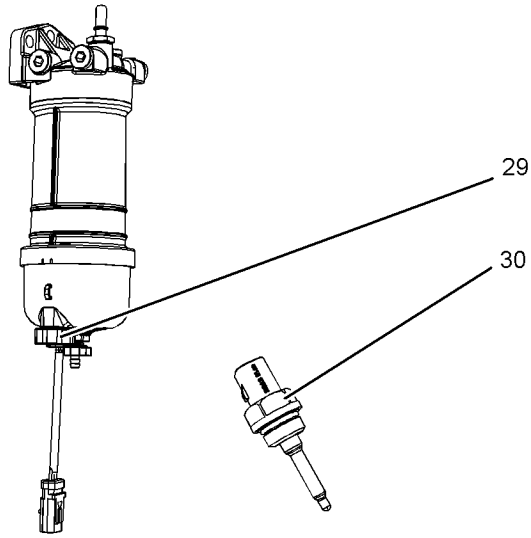

Illustration 40 g03393046

Typical example

- (29) Water in Fuel Switch
- (30) Inlet Air Temperature

Some applications do not require a diagnostic connector (9) installed in the engine wiring harness. The Inlet air temperature sensor (30) will be installed in the induction system between the air cleaner and the inlet manifold.

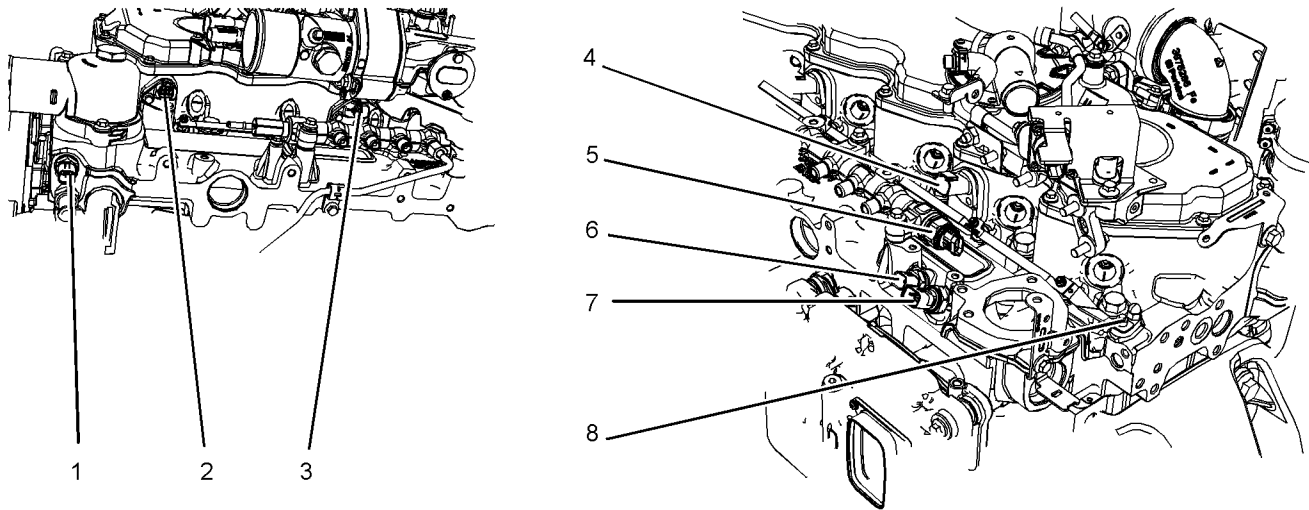

Illustration 41 g03058119

Typical example

- | | | |
|--------------------------------|---------------------------------------|------------------------------------|
| (1) Coolant Temperature Sensor | (4) Injector Connector | (7) Inlet Manifold Pressure Sensor |
| (2) Injector connector | (5) Fuel Pressure Sensor | (8) Glow Plug Connection |
| (3) Injector Connector | (6) Inlet Manifold Temperature Sensor | |

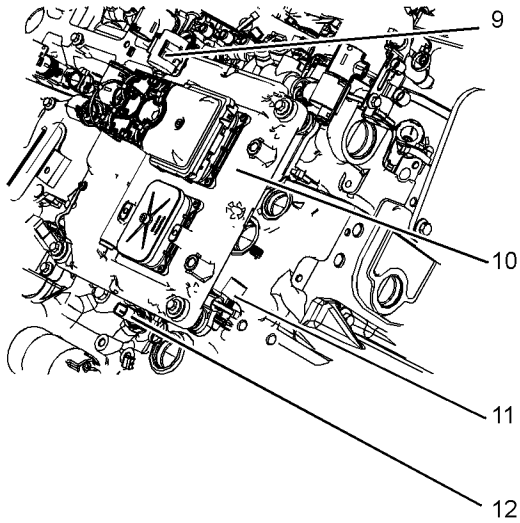

Illustration 42

g03393011

Typical example

- (9) Diagnostic connector
- (10) Electronic Control Module
- (11) Atmospheric Pressure Sensor (Barometric Pressure sensor)
- (12) Oil pressure sensor

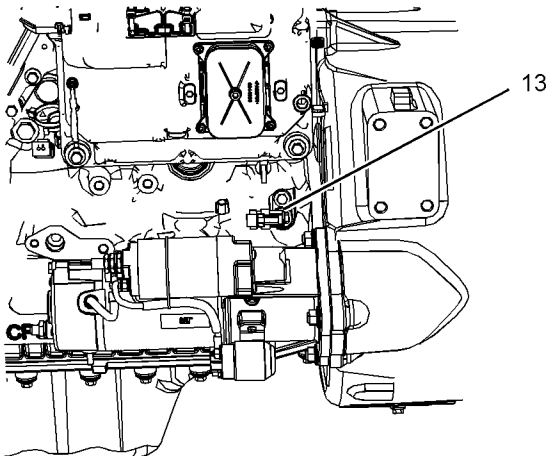

Illustration 43

g03392999

Typical example

- (13) Primary Speed/Timing Sensor

Features and Controls
Sensors and Electrical Components

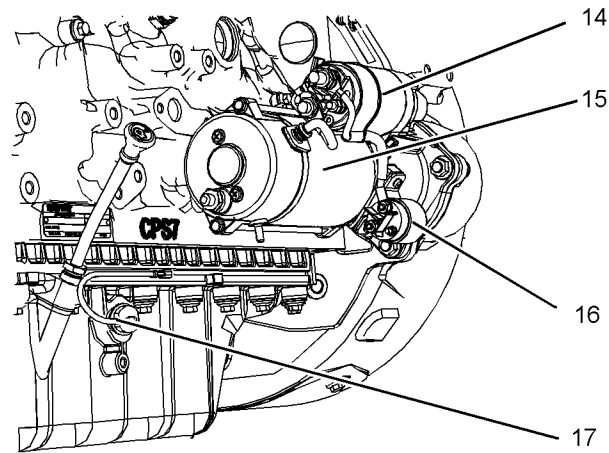

Illustration 44

g03393000

Typical example

(14) Starter Solenoid
(15) Starting Motor

(16) Starter Relay
(17) Oil Level Switch

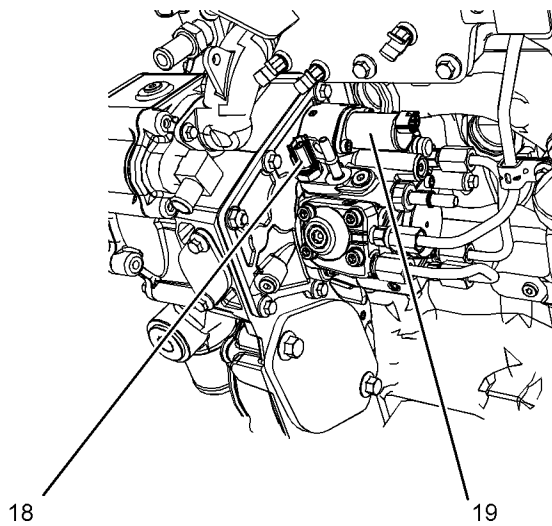

Illustration 45

g03393004

Typical example

(18) Fuel Temperature Sensor
(19) Solenoid for High Pressure Fuel Pump

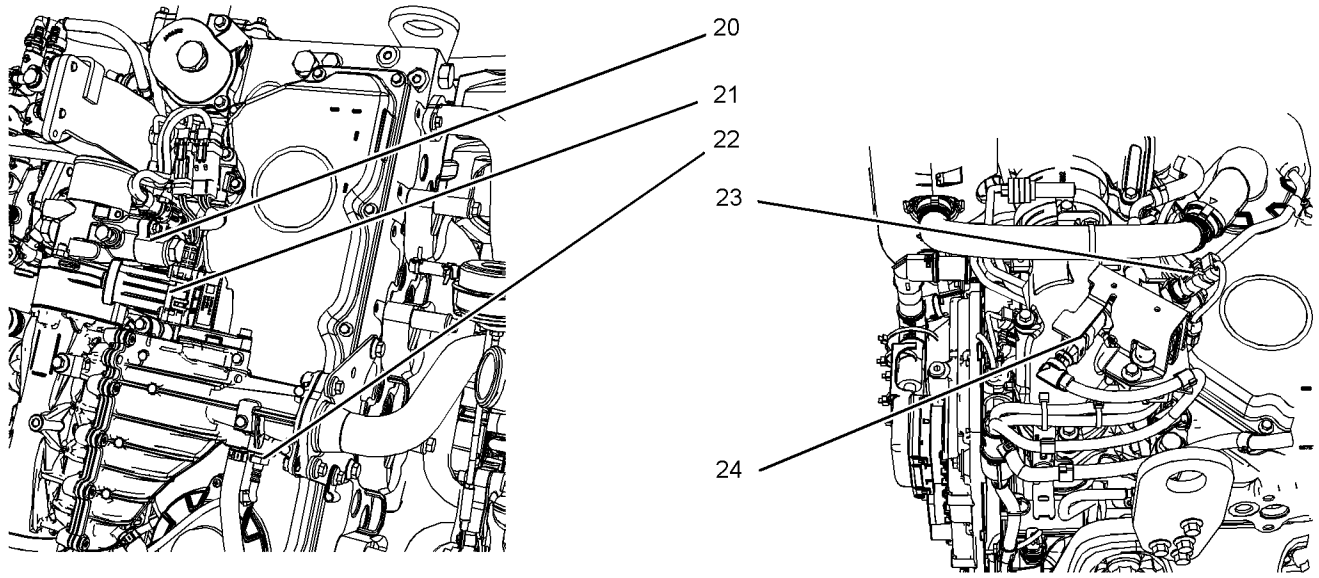

Illustration 46

g03393005

Typical example

(20) Wastegate Regulator
(21) Control Valve for NRS

(22) Temperature Sensor for the NRS
(23) Intake Pressure for the NRS

(24) Differential Pressure for the NRS

Features and Controls
Sensors and Electrical Components

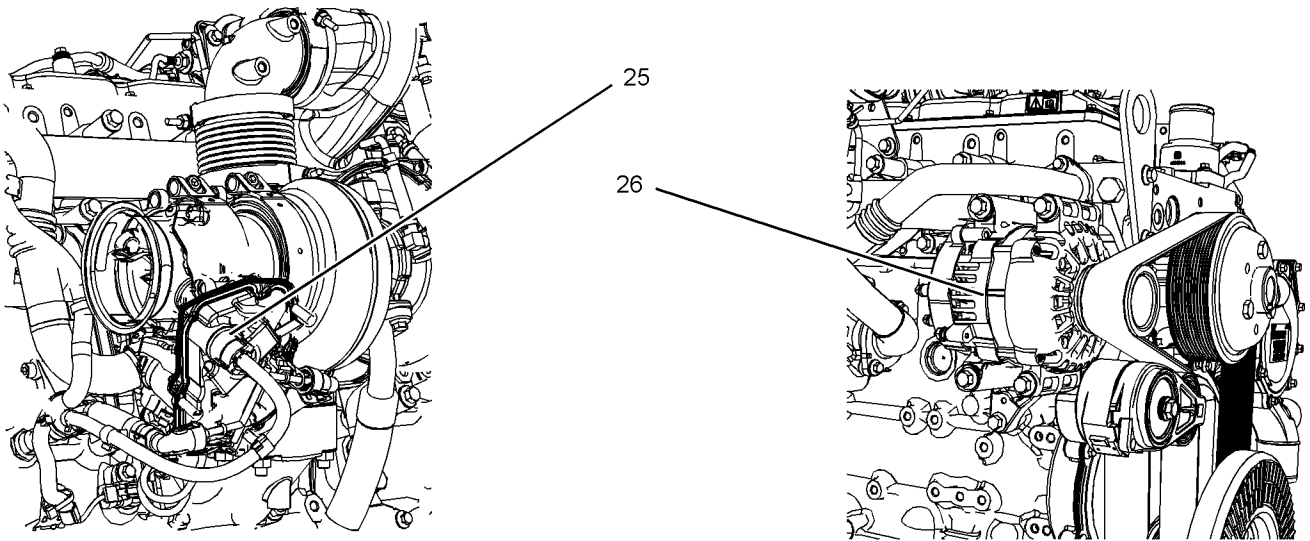

Illustration 47

Typical example

- (25) Back Pressure valve
- (26) Alternator

g03393010

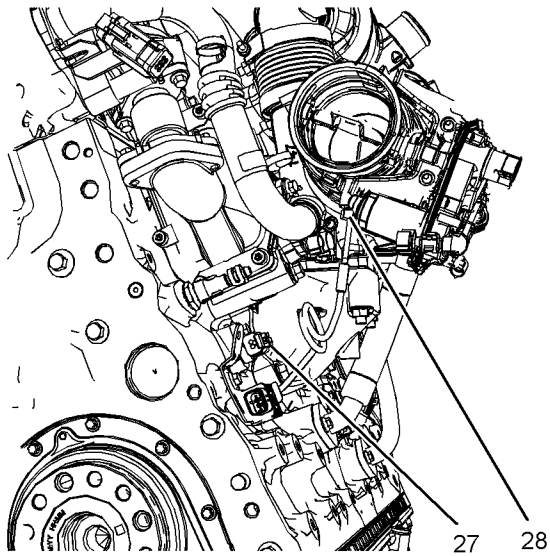

Illustration 48

g03393006

Typical example

- (27) Secondary Speed/Timing sensor
- (28) Exhaust Temperature Sensor

Aftertreatment Components

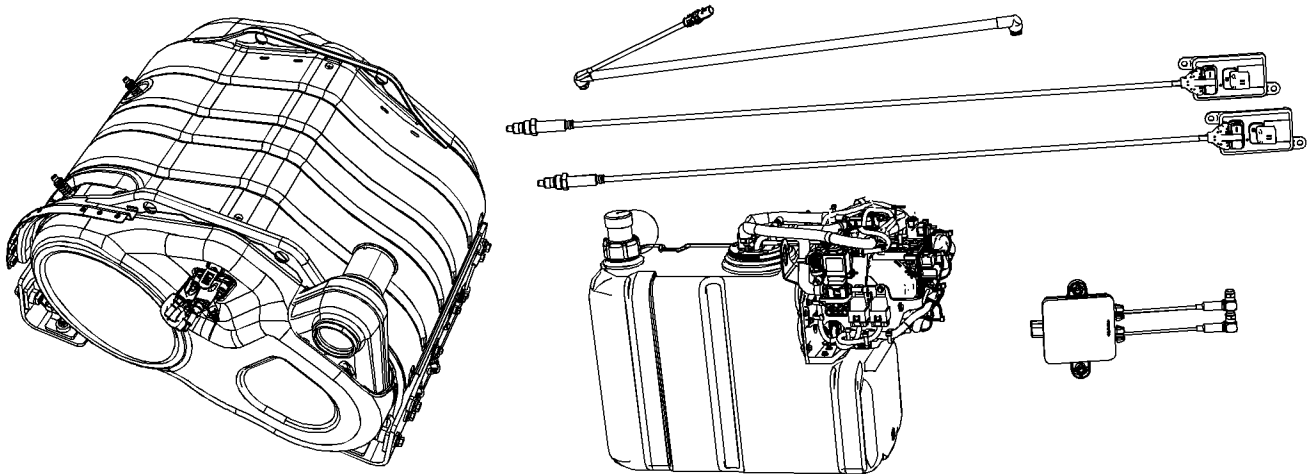

Illustration 49

g03393078

Clean Emissions Module (CEM)

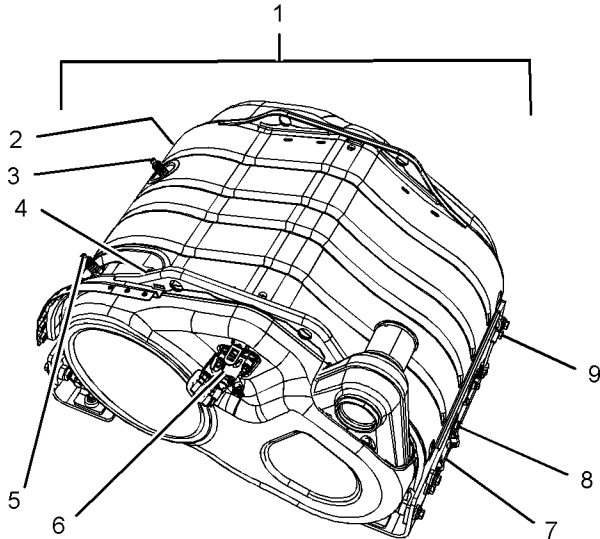

Illustration 50

g03393624

- (1) Clean Emission Module
- (2) Gas Intake Temperature Sensor
- (3) Soot Sensor Antenna
- (4) Location for NO_x Sensing Element
- (5) Soot Sensor Antenna
- (6) Diesel Exhaust Fluid Injector
- (7) Temperature Sensor Connector
- (8) Identification Module
- (9) Gas Temperature Sensor before Selective Catalytic Reduction

CEM Sensors

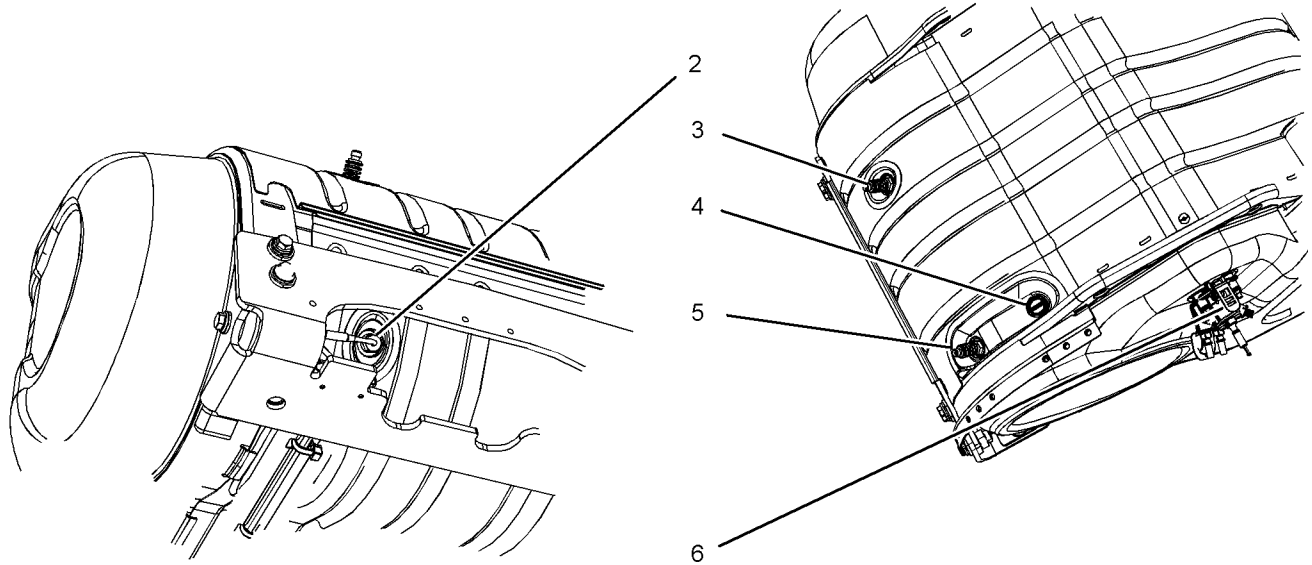

Illustration 51

g03393632

(2) Gas Intake Temperature Sensor
(3) Soot Sensor Antenna

(4) Location for NOx Sensing Element
(5) Soot Sensor Antenna

(6) Diesel Exhaust Fluid Injector

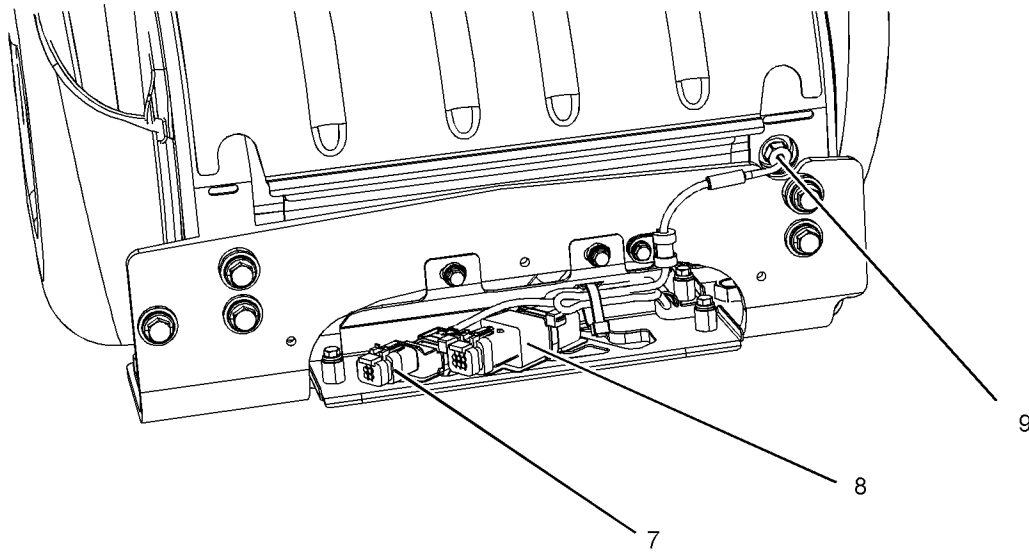

Illustration 52

g03393634

(7) Temperature Sensor Connector
(8) Identification Module

(9) Gas Temperature Sensor before
Selective Catalytic Reduction

Soot and NOx Sensors

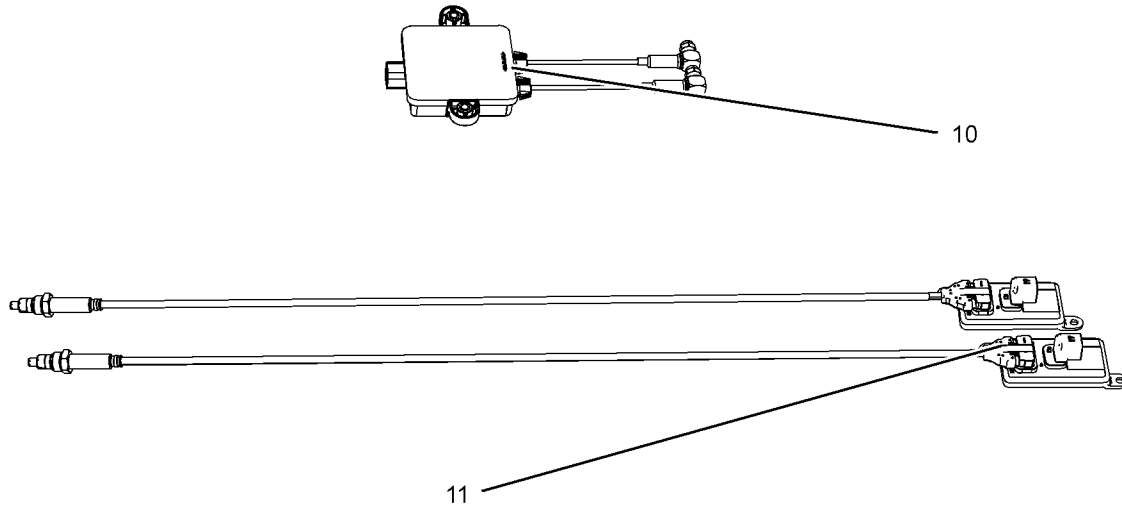

Illustration 53

g03393956

(10) Soot Sensor

(11) NOx Sensors

The location of the soot sensor (10) and NOx sensor (11) will depend on the application.

Pump Electronic Tank Unit (PETU)

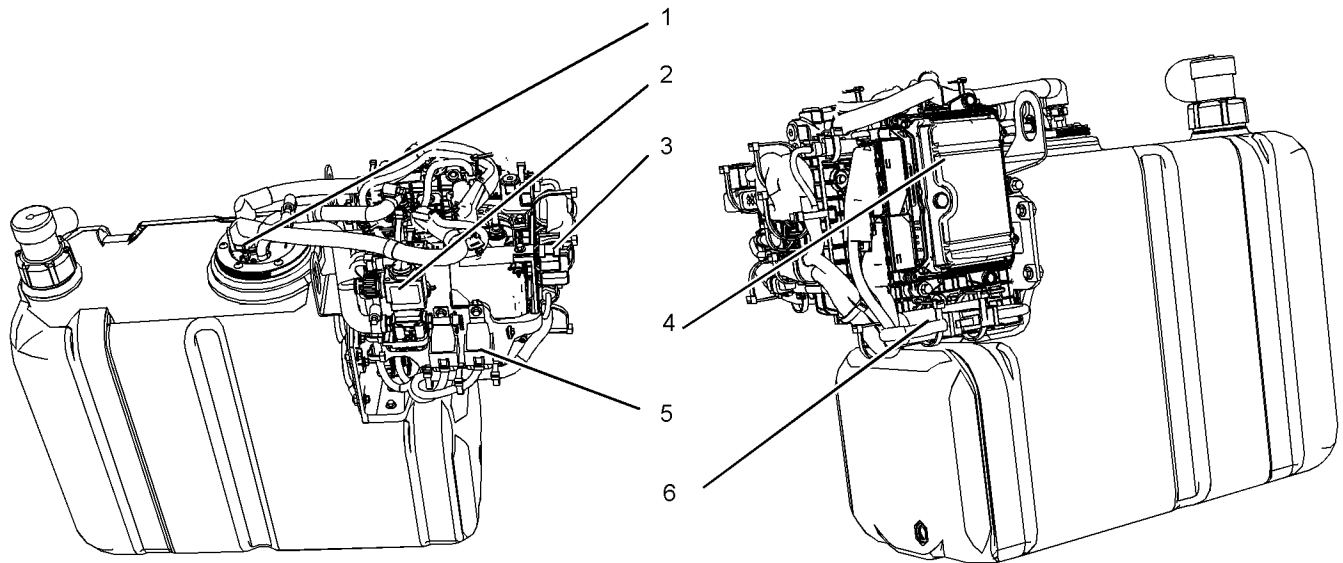

Illustration 54

g03393959

(1) DEF Level Sensor and DEF Temperature
Sensor
(2) Coolant Diverter Valve

(3) Customer Connections
(4) Dosing Control Module
(5) Relays

(6) Voltage Limiting Protection Module

Heated Line

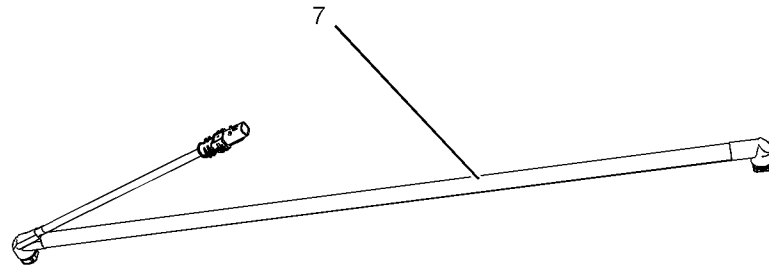

Illustration 55

Typical example

(7) Heated line

g03393960

Engine Diagnostics

i01796959

Self-Diagnostics

SMCS Code: 1000; 1900; 1901; 1902

Caterpillar Electronic Engines have the capability to perform a self-diagnostics test. When the system detects an active problem, a diagnostic lamp is activated. Diagnostic codes will be stored in permanent memory in the Electronic Control Module (ECM). The diagnostic codes can be retrieved by using Caterpillar electronic service tools.

Some installations have electronic displays that provide direct readouts of the engine diagnostic codes. Refer to the manual that is provided by the OEM for more information on retrieving engine diagnostic codes.

Active codes represent problems that currently exist. These problems should be investigated first.

Logged codes represent the following items:

- Intermittent problems
- Recorded events
- Performance history

The problems may have been repaired since the logging of the code. These codes do not indicate that a repair is needed. The codes are guides or signals when a situation exists. Codes may be helpful to troubleshoot problems.

When the problems have been corrected, the corresponding logged fault codes should be cleared.

i03554520

Diagnostic Lamp

SMCS Code: 1000; 1900; 1901; 1902; 7451

A diagnostic lamp is used to indicate the existence of an active fault. A fault diagnostic code will remain active until the problem is repaired. The diagnostic code may be retrieved by using the electronic service tool.

i04907245

Diagnostic Flash Code Retrieval

SMCS Code: 1000; 1900; 1901; 1902

Use the following procedure to retrieve the flash codes if the engine is equipped with a "DIAGNOSTIC" lamp:

1. Move the keyswitch from the on/off two times within 3 seconds.
2. The shutdown warning lamp will flash once.
3. A flashing YELLOW lamp indicates a 3-digit diagnostic code for the engine. The sequence of flashes represents the system diagnostic message. Count the first sequence of flashes in order to determine the first digit of the flash code. After a two second pause, the second sequence of flashes will identify the second digit of the flash code. After the second pause, the third sequence of flashes will identify the flash code.
4. After the diagnostic codes have been displayed, the shutdown lamp will flash twice and the indicator lamp will start to flash the logged diagnostic codes.
5. After the logged diagnostic codes have been displayed, the shutdown lamp will flash three times in order to indicate that the code sequences have finished.

Note: If there are no diagnostic codes or logged diagnostic codes, the system will flash the code 551.

i05406659

Fault Logging

SMCS Code: 1000; 1900; 1901; 1902

The system provides the capability of Fault Logging. When the Electronic Control Module (ECM) generates an active diagnostic code, the code will be logged in the memory of the ECM. The codes that have been logged by the ECM can be identified by the electronic service tool. The active codes that have been logged will be cleared when the fault has been rectified or the fault is no longer active. The following logged faults cannot be cleared from the memory of the ECM without using a factory password: Overspeed, low engine oil pressure, high engine coolant temperature, and aftertreatment codes.

i03554534

Engine Operation with Active Diagnostic Codes

SMCS Code: 1000; 1900; 1901; 1902

If a diagnostic lamp illuminates during normal engine operation, the system has identified a situation that is not within the specification. Use electronic service tools to check the active diagnostic codes.

Note: If the customer has selected “DERATE” and if there is a low oil pressure condition, the Electronic Control Module (ECM) will limit the engine power until the problem is corrected. If the oil pressure is within the normal range, the engine may be operated at the rated speed and load. However, maintenance should be performed as soon as possible.

The active diagnostic code should be investigated. The cause of the problem should be corrected as soon as possible. If the cause of the active diagnostic code is repaired and there is only one active diagnostic code, the diagnostic lamp will turn off.

Operation of the engine and performance of the engine can be limited as a result of the active diagnostic code that is generated. Acceleration rates may be significantly slower. Refer to the Troubleshooting Guide for more information on the relationship between these active diagnostic codes and engine performance.

i01797063

Engine Operation with Intermittent Diagnostic Codes

SMCS Code: 1000; 1900; 1901; 1902

If a diagnostic lamp illuminates during normal engine operation and the diagnostic lamp shuts off, an intermittent fault may have occurred. If a fault has occurred, the fault will be logged into the memory of the Electronic Control Module (ECM).

In most cases, it is not necessary to stop the engine because of an intermittent code. However, the operator should retrieve the logged fault codes and the operator should reference the appropriate information in order to identify the nature of the event. The operator should log any observation that could have caused the lamp to light.

- Low power
- Limits of the engine speed
- Excessive smoke, etc

This information can be useful to help troubleshoot the situation. The information can also be used for future reference. For more information on diagnostic codes, refer to the Troubleshooting Guide for this engine.

i05402551

Configuration Parameters

SMCS Code: 1000; 1900; 1901; 1902

The engine electronic control module (ECM) has two types of configuration parameters. The system configuration parameters and the customer specified parameters.

The electronic service tool is required in order to alter the configuration parameters.

System Configuration Parameters

System configuration parameters affect the emissions of the engine or the power of the engine. System configuration parameters are programmed at the factory. Normally, system configuration parameters would never require changing through the life of the engine. System configuration parameters must be reprogrammed if an ECM is replaced. System configuration parameters do not require reprogrammed if the ECM software is changed. Factory passwords are required to change these parameters.

Table 9

System Configuration Parameters	
Configuration Parameters	Record
Engine Serial Number	
Factory Installed Aftertreatment #1 Identification Number	
DPF #1 Soot Loading Sensing System Configuration Code	
Limp Home Engine Speed Ramp Rate	
System Operating Voltage Configuration	
Rating Number	
CAN Communication Protocol Write Security	
Engine Emissions Operator Inducement Progress Configuration	
Engine Emissions Operator Inducement Regulation Configuration	

Customer Specified Parameters

Customer specified parameters allow the engine to be configured to the exact needs of the application.

The electronic service tool is required in order to alter the customer configuration parameters.

Customer parameters may be changed repeatedly as operational requirements change.

Table 10

Customer Specified Parameters	
Specified Parameters	Record
Throttle Type Channel 1	
Throttle Type Channel 2	
IVS Channel 1	
IVS Channel 2	
Continuous Position Throttle Configuration 1	
Continuous Position Throttle Configuration 2	
Multi Position Throttle Switch Configuration	
Throttle Arbitration	
Equipment ID	
Low Idle Speed	
Delay Engine Shutdown	
Ether Solenoid Configuration	
Engine Idle Shutdown Minimum Ambient Air Temperature	
Engine Idle Shutdown Maximum Ambient Air Temperature	
Engine Idle Shutdown Enable Status	
Engine Idle Shutdown Delay Time	

(continued)

Engine Diagnostics
Configuration Parameters

(Table 10, contd)

Engine Idle Shutdown Ambient Temperature Override Enable Status	
High Soot Load Aftertreatment Protection Enable Status	
Air Shutoff	
Throttle Lock Feature Installation Status	
PTO Mode	
Throttle Lock Engine Set Speed #1	
Throttle Lock Engine Set Speed #2	
Throttle Lock Increment Speed Ramp Rate	
Throttle Lock Decrement Speed Ramp Rate	
Throttle Lock Engine Set Speed Increment	
Throttle Lock Engine Set Speed Decrement	
Monitoring Mode Shutdowns	
Monitoring Mode Derates	
Limp Home Desired Engine Speed	
Engine Acceleration Rate	
Engine Speed Decelerating Ramp Rate	
Intermediate Engine Speed	
Fan	
Engine Fan Control	
Engine Fan Type Configuration	
Engine Cooling Fan Temperature Error Increasing Hysteresis	
Engine Cooling Fan Temperature Error Decreasing Hysteresis	
Engine Cooling Fan Current Ramp Rate	
Engine Cooling Fan Speed	
Top Engine Fan Speed	
Minimum Desired Engine Cooling Fan Speed	
Engine Cooling Fan Solenoid Minimum Current	
Engine Cooling Fan Solenoid Maximum Current	
Engine cooling Fan solenoid Dither Frequency	
Engine Cooling Fan Solenoid Dither Amplitude	
Fan Temperatures	
Engine Fan Control Charge Air Cooler Outlet Temperature Input Enable	
Engine Cooling Fan Maximum Air Flow Charge Air Cooler Outlet Temperature	
Engine Cooling Fan Minimum Air Flow Charge Air Cooler Outlet Temperature	
Engine Cooling Fan Control Coolant Temperature Input Enable Status	
Engine Cooling Fan Maximum Air Flow Coolant Temperature	

(continued)

(Table 10, contd)

Engine Cooling Fan Minimum Air Flow Coolant Temperature	
Engine Cooling Fan Control Transmission Oil Temperature Input Enable Status	
Engine Cooling Fan Maximum Air Flow Transmission Oil Temperature	
Engine Cooling Fan Minimum Air Flow Transmission Oil Temperature	
Engine Cooling Fan Control Hydraulic Oil Temperature Input Enable Status	
Engine Cooling Fan Maximum Air Flow Hydraulic Oil Temperature	
Engine Cooling Fan Minimum Air Flow Hydraulic Oil Temperature	
Engine Cooling Fan Control Auxiliary #1 Temperature Input Enable Status	
Engine Cooling Fan Maximum Air Flow Auxiliary #1 Temperature	
Engine Cooling Fan Minimum Air Flow Auxiliary #1 Temperature	
Engine Cooling Fan Control Auxiliary #2 Temperature Input Enable Status	
Engine Cooling Fan Maximum Air Flow Auxiliary #2 Temperature	
Engine Cooling Fan Minimum Air Flow Auxiliary #2 Temperature	
Other Parameters	
Maintenance Indicator Mode	
Maintenance Level 1 Cycle Interval Hours	
Coolant Level Sensor	
Air Filter Restriction Switch Installation Status	
Air Filter Restriction Switch Configuration	
Fuel/Water Separator Switch Installation Status	
User Defined Switch Installation Status	
Auxiliary Temperature Sensor Installation Status	
Auxiliary Pressure Sensor Installation Status	
Remote Torque Speed Control Enable Status	
Number of Engine Operating Mode Switches	
Engine Operating Mode Configuration	
Glow Plug Start Aid Installation Status	
High Idle Configuration	
Throttle Channel 1 Droop %	
Throttle Channel 2 Droop %	
TSC 1 Droop %	
Min Max / All Speed Governing	
Rated Speed Configuration	

Engine Starting

i05354321

Before Starting Engine

i04935860

SMCS Code: 1000; 1400; 1450

Perform the required daily maintenance and other periodic maintenance before the engine is started. Inspect the engine compartment. This inspection can help prevent major repairs at a later date. Refer to the Operation and Maintenance Manual, "Maintenance Interval Schedule" for more information.

- Ensure that the engine has an adequate fuel supply.
- Ensure that the engine has an adequate diesel exhaust fluid supply
- Open the fuel supply valve (if equipped).

NOTICE

All valves in the fuel return line must be open and fuel supply lines must be open. Damage to the fuel system can occur if fuel lines are closed with the engine in operation.

If the engine has not been started for several weeks, fuel may have drained from the fuel system. Air may have entered the filter housing. Also, when fuel filters have been changed, some air pockets will be trapped in the engine. In these instances, prime the fuel system. Refer to the Operation and Maintenance Manual, "Fuel System - Prime" for more information on priming the fuel system. Also, check that the fuel specification is correct and that the fuel condition is correct. Refer to the Operation and Maintenance Manual, "Fuel Recommendations".

WARNING

Engine exhaust contains products of combustion which may be harmful to your health. Always start and operate the engine in a well ventilated area and, if in an enclosed area, vent the exhaust to the outside.

- Do not start the engine or move any of the controls if there is a "DO NOT OPERATE" warning tag or similar warning tag attached to the start switch or to the controls.
- Reset all of the shutoffs or alarm components.
- Ensure that any driven equipment has been disengaged. Minimize electrical loads or remove any electrical loads.

Cold Weather Starting

SMCS Code: 1000; 1250; 1450; 1453; 1456; 1900

WARNING

Do not use aerosol types of starting aids such as ether. Such use could result in an explosion and personal injury.

Startability will be improved at temperatures below -18°C (0°F) from the use of a jacket water heater or extra battery capacity.

The following items provide a means of minimizing starting problems and fuel problems in cold weather: Engine oil pan heaters, jacket water heaters, fuel heaters and fuel line insulation. For more information, refer to Commercial Diesel Engine Fluids Recommendations, SEBU6251.

Use the procedure that follows for cold weather starting.

Note: Do not adjust the engine speed control during start-up. The electronic control module (ECM) will control the engine speed during start-up.

1. Disengage any driven equipment.
2. Turn the keyswitch to the RUN position. Leave the keyswitch in the RUN position until the warning light for the glow plugs is extinguished.

NOTICE

Do not engage the starting motor when flywheel is turning. Do not start the engine under load.

If the engine fails to start within 30 seconds, release the starter switch or button and wait two minutes to allow the starting motor to cool before attempting to start the engine again.

3. When the warning light for the glow plugs is extinguished cycle the keyswitch. Turn the keyswitch to the OFF position and then to the START position in order to engage the electric starting motor and crank the engine.

Note: The operating period of the warning light for the glow plugs will change due to the temperature of the engine.

4. Allow the keyswitch to return to the RUN position after the engine starts.
5. Repeat step 2 through step 4 if the engine fails to start.

Note: After starting, the engine may be held at low speed for a duration between 1 and 25 seconds to allow engine systems to stabilize. The duration will depend on ambient temperature, time since last run and other factors. The glow plug warning lamp will flash in order to indicate that the engine is been held at low speed.

6. The engine should not be “raced” in order to speed up the warm-up process. Allow the engine to idle for 3 to 5 minutes, or allow the engine to idle until the water temperature indicator begins to rise. When idling after the engine has started in cold weather, increase the engine rpm from 1000 to 1200 rpm. This procedure will warm up the engine more quickly.
7. Operate the engine at low load until all systems reach operating temperature. Check the gauges during the warm-up period.

Following a cold start white smoke can be seen from the tailpipe. This smoke is normal and caused by condensation leaving the exhaust system after warming up. The white smoke should clear following working of the engine.

i05354322

Starting the Engine

SMCS Code: 1000; 1450

Note: Do not adjust the engine speed control during start-up. The electronic control module (ECM) will control the engine speed during start-up.

Starting the Engine

1. Disengage any equipment that is driven by the engine.
2. Turn the keyswitch to the RUN position. Leave the keyswitch in the RUN position until the warning light for the glow plugs is extinguished.

Note: During the key on, the indicator lamps will be illuminated for 2 seconds in order to check lamp operation. If any of the lamps do not illuminate, check the bulb. If any indicator lamps stay illuminated or flash, refer to Troubleshooting, “Indicator Lamp Circuit - Test”.

3. When the warning light for the glow plugs is extinguished cycle the keyswitch. Turn the keyswitch to the OFF position and then to the START position in order to engage the electric starting motor and crank the engine.

Note: The operating period of the warning light for the glow plugs will change due to the temperature of the engine.

NOTICE

Do not engage the starting motor when flywheel is turning. Do not start the engine under load.

If the engine fails to start within 30 seconds, release the starter switch or button and wait two minutes to allow the starting motor to cool before attempting to start the engine again.

4. Allow the keyswitch to return to the RUN position after the engine starts.
5. Repeat step 2 through step 4 if the engine fails to start.
6. After starting, the engine may be held at low speed for a duration between 1 and 25 seconds to allow engine systems to stabilize. The duration will depend on ambient temperature, time since last run and other factors. The glow plug warning light will flash in order to indicate that the engine is been held at low speed.

i03653722

Starting with Jump Start Cables

SMCS Code: 1000; 1401; 1402; 1900

WARNING

Improper jump start cable connections can cause an explosion resulting in personal injury.

Prevent sparks near the batteries. Sparks could cause vapors to explode. Do not allow jump start cable ends to contact each other or the engine.

If the installation is not equipped with a backup battery system, it may be necessary to start the engine from an external electrical source.

For information on troubleshooting the charging system, refer to Special Instruction, REHS0354, “Charging System Troubleshooting”.

Many batteries which are considered unusable are still rechargeable. After jump starting, the alternator may not be able to fully recharge batteries that are severely discharged. The batteries must be charged to the proper voltage with a battery charger. For information on testing and charging, refer to the Special Instruction, SEHS7633, “Battery Test Procedure”.

NOTICE

Using a battery source with the same voltage as the electric starting motor. Use ONLY equal voltage for jump starting. The use of higher voltage will damage the electrical system.

Do not reverse the battery cables. The alternator can be damaged. Attach ground cable last and remove first.

When using an external electrical source to start the engine, turn the generator set control switch to the "OFF" position. Turn all electrical accessories OFF before attaching the jump start cables.

Ensure that the main power switch is in the OFF position before attaching the jump start cables to the engine being started.

1. Turn the start switch on the stalled engine to the OFF position. Turn off all the engine's accessories.
2. Connect one positive end of the jump start cable to the positive cable terminal of the discharged battery. Connect the other positive end of the jump start cable to the positive cable terminal of the electrical source.
3. Connect one negative end of the jump start cable to the negative cable terminal of the electrical source. Connect the other negative end of the jump start cable to the engine block or to the chassis ground. This procedure helps to prevent potential sparks from igniting the combustible gases that are produced by some batteries.

Note: The engine ECM must be powered before the starting motor is operated or damage can occur.

4. Start the engine in the normal operating procedure. Refer to this Operation and Maintenance Manual, "Starting the Engine".
5. Immediately after the engine is started, disconnect the jump start cables in reverse order.

After jump starting, the alternator may not be able to fully recharge batteries that are severely discharged. The batteries must be replaced or charged to the proper voltage with a battery charger after the engine is stopped. Many batteries which are considered unusable are still rechargeable. Refer to Operation and Maintenance Manual, "Battery - Replace" and Testing and Adjusting Manual, "Battery - Test".

Refer to the Electrical Schematic for your engine. Consult your Caterpillar dealer for more information.

i05354355

After Starting Engine

SMCS Code: 1000

After starting, the engine may be held at low speed for a duration between 1 and 25 seconds to allow engine systems to stabilize. The duration will depend on ambient temperature, time since last run and other factors.

Note: In ambient temperatures from 0 to 60°C (32 to 140°F), the warm-up time is approximately 3 minutes. In temperatures below 0°C (32°F), additional warm-up time may be required.

When the engine idles during warm-up, observe the following conditions:

Do not check the high-pressure fuel lines with the engine or the starting motor in operation. If you inspect the engine in operation, always use the proper inspection procedure in order to avoid a fluid penetration hazard. Refer to Operation and Maintenance Manual, "General hazard Information".

- Check for any fluid or for any air leaks at idle rpm and at one-half full rpm (no load on the engine) before operating the engine under load. This check may not be possible in some applications.
- Allow the engine to idle for 3 to 5 minutes, or allow the engine to idle until the water temperature indicator begins to rise. Check all gauges during the warm-up period.

Note: Gauge readings should be observed and the data should be recorded frequently while the engine is operating. Comparing the data over time will help to determine normal readings for each gauge. Comparing data over time will also help detect abnormal operating developments. Significant changes in the readings should be investigated.

Engine Operation

i04907268

Engine Operation

SMCS Code: 1000

Proper operation and maintenance are key factors in obtaining the maximum life and economy of the engine. If the directions in the Operation and Maintenance Manual are followed, costs can be minimized and engine service life can be maximized.

The time that is needed for the engine to reach normal operating temperature can be less than the time taken for a walk-around inspection of the engine.

The engine can be operated at the rated rpm after the engine is started and after the engine reaches operating temperature. The engine will reach normal operating temperature sooner during a low engine speed (rpm) and during a low-power demand. This procedure is more effective than idling the engine at no load. The engine should reach operating temperature in a few minutes.

Avoid excess idling. Excessive idling causes carbon buildup, engine slobber and soot loading of the Diesel Particulate Filter (DPF). These issues are harmful to the engine.

Gauge readings should be observed and the data should be recorded frequently while the engine is operating. Comparing the data over time will help to determine normal readings for each gauge. Comparing data over time will also help detect abnormal operating developments. Significant changes in the readings should be investigated.

Engine Operation and the Aftertreatment System

The exhaust gases and hydrocarbon particles from the engine first pass through Diesel Oxidation Catalyst (DOC). Some of the gasses and matter are oxidized as they pass through the DOC. The gasses then pass through the Diesel Particulate Filter (DPF). The DPF collects the soot and any ash that is produced by the combustion in the engine. During regeneration, the soot is converted into a gas and the ash remains in the DPF. The gasses finally pass through the Selective Catalytic Reduction (SCR). Before the gasses pass through the SCR, Diesel Exhaust Fluid (DEF) is injected into the gas stream. The DEF is stored and controlled by the Pump Electronic Tank Unit (PETU). The mixtures of DEF and the exhaust gas pass through the SCR reducing the NOx in the exhaust emissions.

The DPF may require the exhaust gas temperature to rise in order to remove the soot. If necessary, the back pressure valve operates in order to create the rise in temperature. In some applications, the operation of the back pressure valve will make the engine tone different.

The engine software will control the amount of DEF that will be required in order to keep the exhaust emission compliant.

This design of DPF will not require a service maintenance interval. The DPF can be expected to function properly for the useful life of the engine (emissions durability period), as defined by regulation, subject to prescribed maintenance requirements being followed.

i01646335

Engaging the Driven Equipment

SMCS Code: 1000

1. Operate the engine at one-half of the rated rpm, when possible.
2. Engage the driven equipment without a load on the equipment, when possible.

Interrupted starts put excessive stress on the drive train. Interrupted starts also waste fuel. To get the driven equipment in motion, engage the clutch smoothly with no load on the equipment. This method should produce a start that is smooth and easy. The engine rpm should not increase and the clutch should not slip.
3. Ensure that the ranges of the gauges are normal when the engine is operating at one-half of the rated rpm. Ensure that all gauges operate properly.
4. Increase the engine rpm to the rated rpm. Always increase the engine rpm to the rated rpm before the load is applied.
5. Apply the load. Begin operating the engine at low load. Check the gauges and equipment for proper operation. After normal oil pressure is reached and the temperature gauge begins to move, the engine may be operated at full load. Check the gauges and equipment frequently when the engine is operated under load.

Extended operation at low idle or at reduced load may cause increased oil consumption and carbon buildup in the cylinders. This carbon buildup results in a loss of power and/or poor performance.

i04018250

Fuel Conservation Practices

SMCS Code: 1000; 1250

The efficiency of the engine can affect the fuel economy. Caterpillar's design and technology in manufacturing provides maximum fuel efficiency in all applications. Follow the recommended procedures in order to attain optimum performance for the life of the engine.

- Avoid spilling fuel.

Fuel expands when the fuel is warmed up. The fuel may overflow from the fuel tank. Inspect fuel lines for leaks. Repair the fuel lines, as needed.

- Be aware of the properties of the different fuels. Use only the recommended fuels. Refer to the Operations and Maintenance Manual, "Fuel Recommendations" for further information.
- Avoid unnecessary idling.

Shut off the engine rather than idle for long periods of time.

- Observe the service indicator frequently. Keep the air cleaner elements clean.
- Ensure that the turbocharger is operating correctly. For more information refer to this Operation and Maintenance Manual, "Turbocharger - Inspect".
- Maintain a good electrical system.

One faulty battery cell will overwork the alternator. This fault will consume excess power and excess fuel.

- The belt should be in good condition. Refer to the Systems Operation, Testing and Adjusting, "V - Belt Test" for further information.
- Ensure that all of the connections of the hoses are tight. The connections should not leak.
- Ensure that the driven equipment is in good working order.
- Cold engines consume excess fuel. Utilize heat from the jacket water system and the exhaust system, when possible. Keep cooling system components clean and keep cooling system components in good repair. Never operate the engine without water temperature regulators. All of these items will help maintain operating temperatures.

Cold Weather Operation

i05353504

Cold Weather Operation

SMCS Code: 1000; 1250

Caterpillar Diesel Engines can operate effectively in cold weather. During cold weather, the starting and the operation of the diesel engine is dependent on the following items:

- The type of fuel that is used
- The viscosity of the engine oil
- The operation of the glow plugs
- Optional Cold starting aid
- Battery condition
- Ambient air temperature

Refer to Special Publication, SEBU5898, Cold Weather Recommendations for Caterpillar Machines.

This section will cover the following information:

- Potential problems that are caused by cold-weather operation
- Suggest steps which can be taken in order to minimize starting problems and operating problems when the ambient air temperature is between "0° to -40 °C (32° to -40 °F)".

The operation and maintenance of an engine in freezing temperatures is complex. This complexity is because of the following conditions:

- Weather conditions
- Engine applications

Recommendations from your Caterpillar dealer are based on past proven practices. The information that is contained in this section provides guidelines for cold-weather operation.

Hints for Cold Weather Operation

- After starting the engine, the engine speed will be governed for up to a maximum of 25 seconds. After this period, the engine should be operated at low loads until a minimum operating temperature of 80° C (176° F) is achieved
- Achieving operating temperature will help prevent the intake valves and exhaust valves from sticking.
- The cooling system and the lubrication system for the engine do not lose heat immediately upon shutdown. This means that an engine can be shut down for a period and the engine can still start readily.
- Install the correct specification of engine lubricant before the beginning of cold weather.
- Check all rubber parts (hoses, fan drive belts) weekly.
- Check all electrical wiring and connections for any fraying or damaged insulation.
- Keep all batteries fully charged and warm.
- Fill the fuel tank at the end of each shift.
- Drain the water from the fuel system. Refer to this Operation and Maintenance Manual, "Fuel System Primary Filter/Water Separator - Drain".
- Check the air cleaners and the air intake daily. Check the air intake more often when you operate in snow.
- Ensure that the glow plugs are in working order. Refer to Troubleshooting, "Glow Plug Starting Aid - Test".

WARNING

Personal injury or property damage can result from alcohol or starting fluids.

Alcohol or starting fluids are highly flammable and toxic and if improperly stored could result in injury or property damage.

WARNING

Do not use aerosol types of starting aids such as ether. Such use could result in an explosion and personal injury.

- For jump starting with cables in cold weather, refer to the Operation and Maintenance Manual, "Starting with Jump Start Cables." for instructions.

Viscosity of the Engine Lubrication Oil

Correct engine oil viscosity is essential. Oil viscosity affects the amount of torque that is needed to crank the engine. Refer to this Operation and Maintenance Manual, "Fluid Recommendations" for the recommended viscosity of oil.

Recommendations for the Coolant

Provide cooling system protection for the lowest expected outside temperature. Refer to this Operation and Maintenance Manual, "Fluid Recommendations" for the recommended coolant mixture.

In cold weather, check the coolant often for the correct glycol concentration in order to ensure adequate freeze protection.

Engine Block Heaters

Engine block heaters (if equipped) heat the engine jacket water that surrounds the combustion chambers. This heat provides the following functions:

- Startability is improved.
- Warm up time is reduced.

An electric block heater can be activated once the engine is stopped. A block heater can be 110V dc or 240V dc. The output can be 750/1000W. Consult your Cat dealer for more information.

Idling the Engine

After starting the engine, the engine speed will be governed for a maximum period of 25 seconds. When idling after the engine is started in cold weather, increase the engine rpm from 1000 to 1200 rpm. This increase in RPM will warm up the engine more quickly. Maintaining an elevated low idle speed for extended periods will be easier with the installation of a hand throttle. The engine should not be "raced" in order to speed up the warm-up process.

While the engine is idling, the application of a light load (parasitic load) will assist in achieving the minimum operating temperature. The minimum operating temperature is 80° C (176° F).

Recommendations for Coolant Warm Up

Warm up an engine that has cooled below normal operating temperatures due to inactivity. This procedure should be performed before the engine is returned to full operation. During operation in very cold temperature conditions, damage to engine valve mechanisms can result from engine operation for short intervals. This damage can happen if the engine is started and the engine is stopped many times without being operated in order to warm up completely.

When the engine is operated below normal operating temperatures, fuel and oil are not completely burned in the combustion chamber. This fuel and oil causes soft carbon deposits to form on the valve stems. Generally, the deposits do not cause problems and the deposits are burned off during operation at normal engine operating temperatures.

When the engine is started and the engine is stopped many times without being operated in order to warm up completely, the carbon deposits become thicker. This carbon can cause the following problems:

- Free operation of the valves is prevented.
- Valves become stuck.
- Pushrods may become bent.
- Other damage to valve train components can result.

For this reason, when the engine is started, the engine must be operated until the coolant temperature is 80° C (176° F) minimum. Carbon deposits on the valve stems will be kept at a minimum and the free operation of the valves and the valve components will be maintained.

The engine must be thoroughly warmed in order to keep other engine parts in better condition. Also, the service life of the engine will be generally extended. Lubrication will be improved. There will be less acid and less sludge in the oil. This improvement will provide longer service life for the engine bearings, the piston rings, and other parts. However, limit unnecessary idle time to 10 minutes in order to reduce wear and unnecessary fuel consumption.

The Water Temperature Regulator and Insulated Heater Lines

The engine is equipped with a water temperature regulator. When the engine coolant is below the correct operating temperature, jacket water circulates through the engine cylinder block and into the engine cylinder head. The coolant then returns to the cylinder block via an internal passage that bypasses the valve of the coolant temperature regulator. This coolant return circuit ensures that coolant flows around the engine under cold operating conditions. The water temperature regulator begins to open when the engine jacket water has reached the correct minimum operating temperature. As the jacket water coolant temperature rises above the minimum operating temperature the water temperature regulator opens further allowing more coolant through the radiator to dissipate excess heat.

The progressive opening of the water temperature regulator operates the progressive closing of the bypass passage between the cylinder block and head. This process ensures maximum coolant flow to the radiator in order to achieve maximum heat dissipation.

Note: Do not restrict the air flow. Restriction to the air flow can damage the fuel system. Caterpillar strongly discourages the use of all air flow restriction devices such as radiator shutters. Restriction of the air flow can result in the following: high exhaust temperatures, power loss, excessive fan usage and reduction in fuel economy.

A cab heater is beneficial in very cold weather. The feed from the engine and the return lines from the cab should be insulated in order to reduce heat loss to the outside air.

Insulating the Air Inlet and Engine Compartment

When temperatures below -18°C (-0°F) will be frequently encountered, an air cleaner inlet that is located in the engine compartment may be specified. An air cleaner that is located in the engine compartment may also minimize the entry of snow into the air cleaner. Also, heat that is rejected by the engine helps to warm the intake air.

Additional heat can be retained around the engine by insulating the engine compartment.

Recommendation for Crankcase Breather Protection

Crankcase ventilation gases contain a large quantity of water vapor. This water vapor can freeze in cold ambient conditions and can plug or damage the crankcase ventilation system. If the engine is operated in temperatures below -25°C (-13°F), measures must be taken to prevent freezing and plugging of the breather system. Insulated hoses and a heated canister assembly should be installed.

Consult with your Cat dealer for the recommended breather components for operation from -25° to -40°C (-13° to -40°F).

i04156663

Radiator Restrictions

SMCS Code: 1353; 1396

Caterpillar discourages the use of airflow restriction devices that are mounted in front of radiators. Airflow restriction can cause the following conditions:

- High exhaust temperatures
- Power loss
- Excessive fan usage
- Reduction in fuel economy

Reducing air flow over components will also affect under hood temperatures. Reducing air flow can increase surface temperatures during an aftertreatment regeneration and could affect component reliability.

Reducing air flow can increase surface temperatures during an aftertreatment regeneration and could affect component reliability.

If an airflow restriction device must be used, the device should have a permanent opening directly in line with the fan hub. The device must have a minimum opening dimension of at least 770 cm^2 (120 in^2).

A centered opening that is directly in line with the fan hub is specified in order to prevent an interrupted airflow on the fan blades. Interrupted airflow on the fan blades could cause a fan failure.

Caterpillar recommends a warning device for the inlet manifold temperature and/or the installation of an inlet air temperature gauge. The warning device for the inlet manifold temperature should be set at 75°C (167°F). The inlet manifold air temperature should not exceed 75°C (167°F). Temperatures that exceed this limit can cause power loss and potential engine damage.

i05385898

Fuel and the Effect from Cold Weather

SMCS Code: 1000; 1250; 1280

The following fuels are the grades that are available for Cat engines:

- NO. 1 is ASTM D975 grade 1D S15
- NO. 2 is ASTM D975 grade 2D S15

No. 2 diesel fuel is the most commonly used fuel. Either No. 1 diesel fuel or a blend of No. 1 and No. 2 is best suited for cold-weather operation.

Quantities of No. 1 diesel fuel are limited. No. 1 diesel fuels are usually available during the months of the winter in the colder climates. During cold-weather operation, if No. 1 diesel fuel is not available, use No. 2 diesel fuel, if necessary.

There are three major differences between No. 1 and No. 2 diesel fuel. No. 1 diesel fuel has the following properties:

- Lower cloud point
- Lower pour point
- Lower rating of kJ (BTU) per unit volume of fuel

When No. 1 diesel fuel is used, a decrease in power and in fuel efficiency may be noticed. Other operating effects should not be experienced.

The cloud point is the temperature when a cloud of wax crystals begins to form in the fuel. These crystals can cause the fuel filters to plug. The pour point is the temperature when diesel fuel will thicken. The diesel fuel becomes more resistant to flow through fuel pumps and through fuel lines.

Be aware of these values when diesel fuel is purchased. Anticipate the average ambient temperature of the area. Engines that are fueled in one climate may not operate well if the engines are moved to another climate. Problems can result due to changes in temperature.

Before troubleshooting for low power or for poor performance in the winter, check the type of fuel that is being used.

When No. 2 diesel fuel is used, the following components provide a means of minimizing problems in cold weather:

- Starting aids
- Engine oil pan heaters
- Engine coolant heaters
- Fuel heaters
- Fuel line insulation

For more information on cold-weather operation, see Special Publication, SEBU5898, "Cold Weather Recommendations".

i05354369

Fuel Related Components in Cold Weather

SMCS Code: 1000; 1250; 1280

Fuel Tanks

Condensation can form in partially filled fuel tanks. Top off the fuel tanks after you operate the engine.

Fuel tanks should contain some provision for draining water and sediment from the bottom of the tanks. Some fuel tanks use supply pipes that allow water and sediment to settle below the end of the fuel supply pipe.

Some fuel tanks use supply lines that take fuel directly from the bottom of the tank. If the engine is equipped with this system, regular maintenance of the fuel system filter is important.

Drain the water and sediment from any fuel storage tank at the following intervals: weekly, service intervals and refueling of the fuel tank. This procedure will help prevent water and/or sediment from being pumped from the fuel storage tank and into the engine fuel tank.

Fuel Filters

After you change the fuel filter, always prime the fuel system in order to remove air bubbles from the fuel system. Refer to the Operation and Maintenance Manual in the Maintenance Section for more information on priming the fuel system.

The micron rating and the location of a primary fuel filter is important in cold-weather operation. The In-line filter, primary fuel filter, and the fuel supply line are the most common components that are affected by cold fuel.

NOTICE

In order to maximize fuel system life and prevent premature wear out from abrasive particles in the fuel, a four micron[c] absolute high efficiency fuel filter is required for all Caterpillar Electronic Unit Injectors. Caterpillar High Efficiency Fuel Filters meet these requirements. Consult your Cat dealer for the proper part numbers.

Fuel Heaters

Fuel heaters help to prevent fuel filters from plugging in cold weather due to waxing. A fuel heater should be installed in the fuel system before the electric fuel pump.

For further information on fuel heaters, consult your Cat dealer.

i04928593

Diesel Exhaust Fluid in Cold Weather**SMCS Code:** 108K

Due to the freezing point of Diesel Exhaust Fluid (DEF) the aftertreatment system is equipped with electrically heated DEF lines. The system also has a coolant heated element in the DEF tank. For information on DEF refer to this Operation and Maintenance Manual, "Fluid Recommendations".

Engine Stopping

i05406628

Stopping the Engine

SMCS Code: 1000

NOTICE

Stopping the engine immediately after the engine has been working under load, can result in overheating and accelerated wear of the engine components.

Avoid accelerating the engine prior to shutting down the engine.

Avoiding hot engine shutdowns will maximize turbo-charger shaft and bearing life. Also, selective catalytic reduction component life.

Note: Individual applications will have different control systems. Ensure that the shutoff procedures are understood. Use the following general guidelines in order to stop the engine.

1. Remove the load from the engine. Reduce the engine speed to low idle. Allow the engine to idle for 5 minutes in order to cool the engine.
2. Stop the engine after the cool down period according to the shutoff system on the engine and turn the ignition keyswitch to the OFF position. If necessary, refer to the instructions that are provided by the OEM.

Note: Some applications the engine will continue to operate after the keyswitch is turned to the OFF position. The engine will operate for a short time in order to allow engine components to cool.

3. Allow at least 2 minutes after the engine has stopped before you turn the battery disconnect switch to OFF. Disconnecting the battery power too soon will prevent purging of the DEF fluid lines after the engine is shut down. Also, during the 2 minutes the engine electronic control module is active, storing information from the engine and aftertreatment sensors.

Delayed Engine Shutdown (if Equipped)

The delayed engine shutdown allows the engine to run for a time after the engine start switch is turned to the OFF position in order to cool the system components. The engine start switch key may be removed.

Note: There may be regulations that define the requirements for the operator and/or support personnel to be present when the engine is running.

WARNING

Leaving the machine unattended when the engine is running may result in personal injury or death. Before leaving the machine operator station, neutralize the travel controls, lower the work tools to the ground and deactivate all work tools, and place the lever for the hydraulic lockout control in the LOCKED position.

Leaving the engine unattended while running may result in property damage in the event of a malfunction.

Note: An authorized dealer can change the maximum run time value up to 30 minutes but the default setting is 10 minutes.

An override can be enabled so that the delayed engine shutdown will not operate. Overriding delayed engine shutdown may reduce engine and system component life. The override is operated by the keyswitch.

At any time during a delayed engine shutdown, the engine start switch may be turned to the ON position. The engine may be placed back into service.

i03554860

Emergency Stopping

SMCS Code: 1000; 7418

NOTICE

Emergency shutoff controls are for EMERGENCY use ONLY. DO NOT use emergency shutoff devices or controls for normal stopping procedure.

Ensure that any components for the external system that support the engine operation are secured after the engine is stopped.

Emergency Stop Button

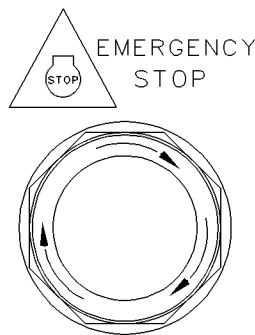

Illustration 56

g00104303

Typical emergency stop button

The emergency stop button is in the OUT position for normal engine operation. Push the emergency stop button. The engine will not start when the button is locked. Turn the button clockwise in order to reset.

Refer to Operation and Maintenance Manual, "Features and Controls" for the location and the operation of the emergency stop button.

i05402556

After Stopping Engine

SMCS Code: 1000

Note: Before you check the engine oil, do not operate the engine. Wait for at least 10 minutes after the engine has stopped in order to allow the engine oil to return to the oil pan.

WARNING

Contact with high pressure fuel may cause fluid penetration and burn hazards. High pressure fuel spray may cause a fire hazard. Failure to follow these inspection, maintenance and service instructions may cause personal injury or death.

- Diesel Exhaust Fluid (DEF) purge, do not disconnect the battery disconnect switch until the DEF purge has been completed. The procedure is automatically controlled and will take approximately 2 minutes.
- After the engine has stopped, you must wait for 10 minutes in order to allow the fuel pressure to be purged from the high-pressure fuel lines before any service or repair is performed on the engine fuel lines. If necessary, perform minor adjustments. Repair any leaks from the low-pressure fuel system and from the cooling, lubrication, or air systems. Replace any high-pressure fuel line that has leaked. Refer to Disassembly and Assembly Manual, "Fuel Injection Lines - Install".
- Check the crankcase oil level. Maintain the oil level between the "MIN" mark and the "MAX" mark on the engine oil level gauge.
- If the engine is equipped with a service hour meter, note the reading. Perform the maintenance that is in the Operation and Maintenance Manual, "Maintenance Interval Schedule".
- Fill the fuel tank, in order to help prevent accumulation of moisture in the fuel. Do not overfill the fuel tank.
- Fill the DEF tank, a low level of DEF in the tank can result in engine de-rate.

NOTICE

Only use antifreeze/coolant mixtures recommended in this Operation and Maintenance Manual, "Refill Capacities and Recommendations" topic or in this Operation and Maintenance Manual, "Fluid Recommendations" topic. Failure to do so can cause engine damage.

WARNING

Pressurized System: Hot coolant can cause serious burns. To open the cooling system filler cap, stop the engine and wait until the cooling system components are cool. Loosen the cooling system pressure cap slowly in order to relieve the pressure.

- Allow the engine to cool. Check the coolant level.
- Check the coolant for correct antifreeze protection and the correct corrosion protection. Add the correct coolant/water mixture, if necessary.
- Perform all required periodic maintenance on all driven equipment. This maintenance is outlined in the instructions from the OEM.

Maintenance Section

i04907693

Refill Capacities

i04907690

Refill Capacities

SMCS Code: 1000; 1348; 1395; 7560

Lubrication System

The refill capacities for the engine crankcase reflect the approximate capacity of the crankcase or sump plus standard oil filters. Auxiliary oil filter systems will require additional oil. Refer to the OEM specifications for the capacity of the auxiliary oil filter. Refer to the Operation and Maintenance Manual, "Maintenance Section" for more information on Lubricant Specifications.

Table 11

Engine Refill Capacities		
Compartment or System	Minimum	Maximum
Crankcase Oil Sump ⁽¹⁾	13.5 L (3.56 US gal)	16.5 L (4.36 US gal)

⁽¹⁾ These values are the approximate capacities for the crankcase oil sump (aluminum) which includes the standard factory installed oil filters. Engines with auxiliary oil filters will require additional oil. Refer to the OEM specifications for the capacity of the auxiliary oil filter. The design of the oil pan can change the oil capacity of the oil pan.

Cooling System

Refer to the OEM specifications for the External System capacity. This capacity information will be needed in order to determine the amount of coolant/antifreeze that is required for the Total Cooling System.

Table 12

Engine Refill Capacities	
Compartment or System	Liters
Engine Only	15 L (3.96 US gal)
External System Per OEM ⁽¹⁾	

⁽¹⁾ The External System includes a radiator or an expansion tank with the following components: heat exchanger and piping. Refer to the OEM specifications. Enter the value for the capacity of the External System in this row.

Fluid Recommendations

SMCS Code: 1280; 1348; 1395; 7560

Engine Lubrication Oil

NOTICE

These recommendations are subject to change without notice. Contact your local Caterpillar dealer for the most up-to-date fluids recommendations.

- EMA _____ Engine Manufacturers Association
- API _____ American Petroleum Institute
- SAE _____ Society Of Automotive Engineers Inc.
- DEO-ULS _____ Diesel Engine Oil-Ultra Low Sulfur

Cat DEO-ULS

Cat DEO-ULS is developed and tested in order to provide superior protection and life for your Caterpillar engines.

- Better Detergents
- Advanced Additive Package
- Enhanced Dispersants
- Improved Protection from Thermal breakdown and Oxidation Breakdown

Due to significant variations in the quality and in the performance of commercially available oils, Caterpillar makes the following recommendations:

- **Cat DEO-ULS (SAE 10W-30)**
- **Cat DEO-ULS (SAE 15W-40)**

Cat DEO-ULS Multigrade oil is available in various viscosity grades that include SAE 10W-30 and SAE 15W-40. To choose the correct viscosity grade for the ambient temperature, see illustration 57. Multigrade oils provide the correct viscosity for a broad range of operating temperatures. Multigrade oils are also effective in maintaining low oil consumption and low levels of piston deposits.

Consult your Caterpillar dealer for part numbers and for available sizes of containers.

Note: Cat DEO-ULS in SAE 15W-40 passes the following proprietary tests: sticking of the piston ring, oil control tests, wear tests and soot tests. Proprietary tests help ensure that Caterpillar multigrade oil provides superior performance in Caterpillar Diesel Engines. In addition, Cat DEO-ULS Multigrade oil exceeds many of the performance requirements of other manufacturers of diesel engines. Therefore, this oil is an excellent choice for many mixed fleets. **True high performance oil is produced with a combination of the following factors: industry standard tests, proprietary tests, field tests and prior experience with similar formulations. The design and the development of Caterpillar lubricants that are both high performance and high quality are based on these factors.**

Commercial Oils

Note: Non-Caterpillar commercial oils are second choice oils.

NOTICE

Caterpillar require the use of the following specification of engine oil. Failure to use the appropriate specification of engine oil will reduce the life of your engine. Failure to use the correct specification of engine will also reduce the life and the effectiveness of your aftertreatment system.

Table 13

API Classifications for the Industrial Engine
Oil Specification
ECF-3 CJ-4 AECA E9

NOTICE

Failure to follow these oil recommendations can cause shortened engine service life due to deposits and/or excessive wear.

Note: Refer to Special Publication, SEBU6251, "Caterpillar Commercial Diesel Engine Fluids Recommendations" for additional information that relates to lubrication for your engine.

Lubricant Viscosity Recommendations

The proper SAE viscosity grade of oil is determined by the minimum ambient temperature during cold engine start-up, and the maximum ambient temperature during engine operation.

Refer to illustration 57 (minimum temperature) in order to determine the required oil viscosity for starting a cold engine.

Refer to illustration 57 (maximum temperature) in order to select the oil viscosity for engine operation at the highest ambient temperature that is anticipated.

Note: Generally, use the highest oil viscosity that is available to meet the requirement for the temperature at start-up.

If ambient temperature conditions at engine start-up require the use of multigrade SAE 0W oil, SAE 0W-40 viscosity grade is preferred.

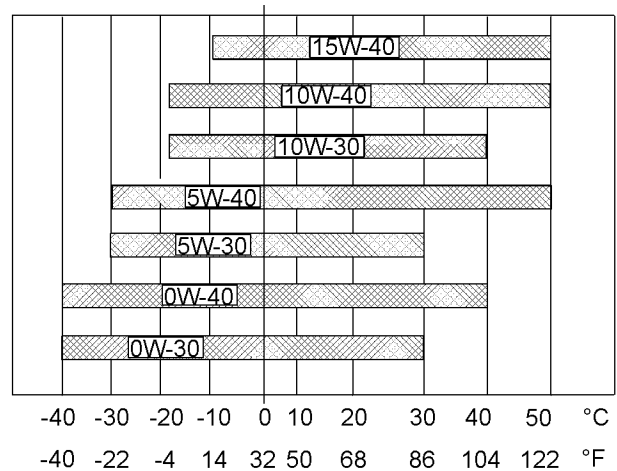

Illustration 57

g03329687

Supplemental heat is recommended for cold soaked starts below the minimum ambient temperature. Supplemental heat may be required for cold soaked starts that are above the minimum temperature that is stated, depending on the parasitic load and other factors. Cold soaked starts occur when the engine has not been operated for a period of time. This will allow the oil to become more viscous due to cooler ambient temperatures.

S·O·S Oil Analysis

Caterpillar has developed a tool for maintenance management that evaluates oil degradation and the tool also detects the early signs of wear on internal components. The Caterpillar tool for oil analysis is called S·O·S Oil Analysis and the tool is part of the S·O·S Services program. S·O·S Oil Analysis divides oil analysis into three categories:

- Wear Analysis
- Oil condition
- Additional tests

The wear analysis monitors metal particles, some oil additives, and some contaminants.

Oil condition uses infrared (IR) analysis to evaluate the chemistry of the oil. Infrared analysis is also used to detect certain types of contamination.

Additional tests are used to measure contamination levels from water, fuel, or coolant. Oil viscosity and corrosion protection can be evaluated, as needed.

Refer to Special Publication, SEBU6251, Caterpillar Commercial Diesel Engine Fluids Recommendations or contact your local Caterpillar dealer for additional information concerning the S·O·S Oil Analysis program.

Lubricating Grease

Caterpillar provides a range of moderate greases to extremely high performance greases in order to service the entire line of Caterpillar products that operate throughout the wide variety of climates. You will always be able to find a grease that will meet your machines requirements for a certain application. Caterpillar grease products often exceed Caterpillar specifications.

Before selecting a grease products for any application, the performance requirements must be determined. Consult the grease recommendations that are made by the OEM for the equipment when the equipment is operated in the expected conditions. Then, consult with your Caterpillar dealer for a list of greases and the following related characteristics.

- Performance specifications
- Available sizes of containers
- Part numbers

Always choose a grease that meets the recommendations that are specified by the equipment manufacturer for the application, or choose a grease that exceeds the recommendations that are specified by the equipment manufacturer for the application.

If it is necessary to choose a single grease for use on all of the equipment at one site, always choose a grease that meets the requirements of the most demanding application. A product that barely meets the minimum performance requirements will shorten the life of the part. Use the grease that yields the least total operating cost. Base this cost on an analysis that includes the costs of the parts, the labor, the downtime, and the cost of the grease that is used.

Some greases are not chemically compatible. Consult your supplier in order to determine if two or more greases are compatible.

Purge the grease from a joint at the following times:

- Switching from one grease to another grease
- Switching from one supplier to another supplier

Note: All Caterpillar brand name greases are compatible with each other.

Note: Refer to Special Publication, SEBU6251, "Caterpillar Commercial Diesel Engine Fluids Recommendations " for additional information that relates to lubrication for your engine.

Fuel

Refer to Special Publication, SEBU6251, "Caterpillar Commercial Diesel Engine Fluids Recommendations " for the Caterpillar Specification for distillate fuel and for additional information that relates to fuel for your engine.

Ultra low Sulfur Diesel (ULSD)

Your Caterpillar Diesel Engine must use ultra low sulfur diesel fuel. This fuel complies with the emissions regulations that are prescribed by the Environmental Protection Agency of the United States.

Engines that are manufactured by Caterpillar are certified with the fuel that is prescribed by the United States Environmental Protection Agency. Engines that are manufactured by Caterpillar are certified with the fuel that is prescribed by the European Certification. Caterpillar does not certify diesel engines on any other fuel.

Note: The owner and the operator of the engine has the responsibility of using the fuel that is prescribed by the United States Environmental Protection Agency and other appropriate regulatory agencies.

Fuel tank inlet labels are installed in order to ensure that the correct fuels are used. Illustration 58 is an example of one of the labels designs that will be installed.

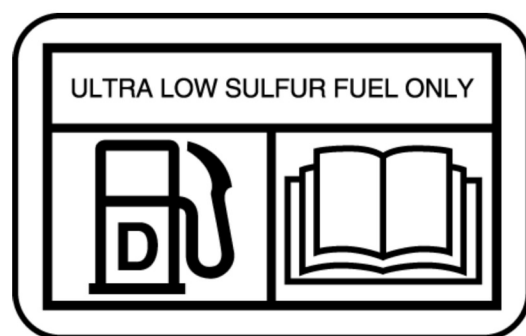

Illustration 58

g02157153

Typical example

Fuel Additives

Many types of fuel additives are available. Caterpillar does not generally recommend the use of fuel additives.

In special circumstances, Caterpillar recognizes the need for fuel additives. Fuel additives need to be used with caution. The additive may not be compatible with the fuel. Some additives may precipitate. This action causes deposits in the fuel system. The deposits may cause seizure. Some additives may be corrosive and some additives may be harmful to the elastomers in the fuel system.

Some additives may damage emission control systems. Some additives may cause the amount of sulfur in the fuel to be greater than 15 ppm.

Contact your fuel supplier for those circumstances when fuel additives are required. Your fuel supplier can recommend the best additives for your application and for the proper level of treatment.

Note: For the best results, your fuel supplier should treat the fuel when additives are necessary.

Diesel Exhaust Fluid

General Information

Diesel Exhaust Fluid (DEF) is a liquid that is injected into the exhaust system of engines equipped with Selective Catalytic Reduction (SCR) systems. SCR reduces emissions of nitrogen oxides (NOx) in diesel engine exhaust.

In engines equipped with SCR emissions reduction system, DEF is injected in controlled amounts into the engine exhaust stream. At the elevated exhaust temperature, urea in DEF is converted to ammonia. The ammonia chemically reacts with NOx in diesel exhaust in the presence of the SCR catalyst. The reaction converts NOx into harmless nitrogen (N₂) and water (H₂O).

DEF is known by many brands including those that carry the AdBlue or API certification.

DEF Recommendations

For use in Cat engines, DEF must meet all the requirements defined by ISO 22241-1 Requirements.

Caterpillar recommends the use of DEF available through the Cat parts ordering system for use in Cat engines equipped with SCR systems. Refer to Table 14 for part number information:

Table 14

Cat Part Number	Container Size
350-8733	2.5 gal bottle
350-8734	1000-L tote

In North America, commercial DEF that is API approved and meets all the requirements defined in ISO 22241-1 may be used in Cat engines that are equipped with SCR systems.

Outside of North America, commercial DEF that meets all requirements defined in ISO 22241-1 may be used in Cat engines that are equipped with SCR systems.

The supplier should provide documentation to prove the DEF is compliant with the requirements of ISO 22241-1.

NOTICE

Cat does not warrant the quality or performance of non-Cat fluids.

NOTICE

Do not use agriculture grade urea solutions. Do not use any fluids that do not meet ISO 22241-1 Requirements in SCR emissions reduction systems. Use of these fluids can result in numerous problems including damage to SCR equipment and a reduction in NOx conversion efficiency.

DEF is a solution of solid urea that is dissolved in demineralized water to produce a final concentration of 32.5% urea. DEF concentration of 32.5% is optimal for use in SCR systems. DEF solution of 32.5% urea has the lowest attainable freeze point of -11.5° C (11.3° F). DEF concentrations that are higher or lower than 32.5% have higher freeze points. DEF dosing systems and ISO 22241-1 specifications are designed for a solution that is approximately 32.5%.

Caterpillar offers a refractometer, Cat part number 360-0774, that can be used to measure DEF concentration. Follow the instructions provided with the instrument. Appropriate commercial portable refractometers can be used to determine urea concentration. Follow the instructions from the manufacturer.

DEF Guidelines

DEF solution is typically colorless and clear. Changes to color or clarity are indicators of quality issues. Quality of DEF can degrade when stored and handled inappropriately or if DEF is not protected from contamination. Details are provided below.

If quality issues are suspected, testing of DEF should focus on urea percentage, alkalinity as NH₃ and biuret content. DEF that does not pass all these tests or that is no longer clear should not be used.

Materials compatibility

DEF is corrosive. Due to the corrosion caused, DEF must be stored in tanks constructed of approved materials. Recommended storage materials:

Stainless Steels:

Refill Capacities Fluid Recommendations

- 304 (S30400)
- 304L (S30403)
- 316 (S31600)
- 316L (S31603)

Alloys and metals:

- Chromium Nickel (CrNi)
- Chromium Nickel Molybdenum (CrNiMo)
- Titanium

Non-metallic materials:

- Polyethylene
- Polypropylene
- Polyisobutylene
- Teflon (PFA)
- Polyfluoroethylene (PFE)
- Polyvinylidene fluoride (PVDF)
- Polytetrafluoroethylene (PTFE)

Materials NOT compatible with DEF solutions include Aluminum, Magnesium, Zinc, Nickel coatings, Silver and Carbon steel and Solders containing any of the above. Unexpected reactions may occur if DEF solutions come in contact with any non-compatible material or unknown materials.

Bulk storage

Follow all local regulations covering bulk storage tanks. Follow proper tank construction guidelines. Tank volume typically should be 110% of planned capacity. Appropriately vent indoor tanks. Plan for control of overflow of the tank. Heat tanks that dispense DEF in cold climates.

Bulk tank breathers should be fitted with filtration to keep airborne debris from entering the tank. Desiccant breathers should not be used because water will be absorbed, which potentially can alter DEF concentration.

Handling

Follow all local regulations covering transport and handling. DEF transport temperature is recommended to be -5°C (23°F) to 25°C (77°F). All transfer equipment and intermediate containers should be used exclusively for DEF. Containers should not be reused for any other fluids. Ensure that transfer equipment is made from DEF-compatible materials. Recommended material for hoses and other non-metallic transfer equipment include:

- Nitrile Rubber (NBR)
- Fluoroelastomer (FKM)
- Ethylene Propylene Diene Monomer (EPDM)

The condition of hoses and other nonmetallics that are used with DEF should be monitored for signs of degradation. DEF leaks are easily recognizable by white urea crystals that accumulate at the site of the leak. Solid urea can be corrosive to galvanized or unalloyed steel, aluminum, copper, and brass. Leaks should be repaired immediately to avoid damage to surrounding hardware.

Cleanliness

Contaminants can degrade the quality and life of DEF. Filtering DEF is recommended when dispensed into the DEF tank. Filters should be compatible with DEF and should be used exclusively with DEF. Check with the filter supplier to confirm compatibility with DEF before using. Mesh-type filters using compatible metals, such as stainless steel, are recommended. Paper (cellulose) media and some synthetic filter media are not recommended because of degradation during use.

Care should be taken when dispensing DEF. Spills should be cleaned immediately. Machine or engine surfaces should be wiped clean and rinsed with water. Caution should be used when dispensing DEF near an engine that has recently been running. Spilling DEF onto hot components will cause harmful vapors.

Stability

DEF fluid is stable when stored and handled properly. The quality of DEF rapidly degrades when stored at high temperatures. The ideal storage temperature for DEF is between -9°C (15.8°F) and 25°C (77°F). DEF that is stored above 35°C (95°F) for longer than 1 month must be tested before use. Testing should evaluate Urea Percentage, Alkalinity as NH_3 and Biuret content.

The length of storage of DEF is listed in the following table:

Table 15

Storage Temperature	Expected DEF Life
Below 25°C (77°F)	18 months
25°C (77°F) to 30°C (86°F)	12 months
30°C (86°F) to 35°C (95°F)	6 months
Above 35°C (95°F)	test quality before use

Refer to ISO 22241 document series for more information about DEF quality control.

Note: Dispose of all fluids according to applicable regulations and mandates.

Coolant

The following two coolants are used in Caterpillar diesel engines:

Preferred – Cat ELC (Extended Life Coolant) or a commercial extended life coolant that meets the Caterpillar EC-1 specification

Acceptable – A Cat DEAC (Diesel Engine Antifreeze/Coolant) or a commercial heavy-duty antifreeze that meets ASTM D6210 specifications

NOTICE

The Caterpillar industrial engine must be operated with a 1:1 mixture of water and glycol. This concentration allows the NOx reduction system to operate correctly at high ambient temperatures.

NOTICE

Do not use a commercial coolant/antifreeze that only meets the ASTM D3306 or equivalent specification. This type of coolant/antifreeze is made for light duty automotive applications.

Use only the coolant/antifreeze that is recommended.

Caterpillar recommends a 1:1 mixture of water and glycol. This mixture of water and glycol will provide optimum heavy-duty performance as an antifreeze.

Note: Cat DEAC does not require a treatment with an SCA at the initial fill. Commercial heavy-duty antifreeze that meets ASTM D6210 specifications MAY require a treatment with an SCA at the initial fill. Read the label or the instructions that are provided by the OEM of the product.

In stationary engine applications that do not require anti-boil protection or freeze protection, a mixture of SCA and water is acceptable. Caterpillar recommends a 6 percent to 8 percent concentration of SCA in those cooling systems. Distilled water or deionized water is preferred. Water which has the recommended properties may be used.

Table 16

Coolant Service Life	
Coolant Type	Service Life ⁽¹⁾
Cat ELC	12000 Service Hours or Six Years ⁽²⁾
Commercial coolant that meets the Caterpillar EC-1 Specification	6000 Service Hours or Six Years ⁽³⁾

(continued)

(Table 16, contd)

Cat DEAC	3000 Service Hours or Three Years
Commercial Heavy-Duty Coolant/Antifreeze that meets ASTM D6210	3000 Service Hours or Two Years

- (1) Use the interval that occurs first. The cooling system must also be flushed out at this time.
- (2) Cat ELC Extender must be added at 6000 service hours or one half of the service life of the Cat ELC. Refer to your machine Operation and Maintenance Manual for exceptions.
- (3) An extender must be added at 3000 service hours or one half of the service life of the coolant.

Note: Refer to Special Publication, SEBU6251, "Caterpillar Commercial Diesel Engine Fluids Recommendations" for additional information that relates to coolant for your engine.

S·O·S Coolant Analysis

Table 17

Recommended Interval		
Type of Coolant	Level 1	Level 2
DEAC	Every 250 Hours ⁽¹⁾	Yearly ⁽¹⁾
ELC	Optional ⁽¹⁾	Yearly

- (1) The Level 2 Coolant Analysis should be performed sooner if a problem is identified by a Level 1 Coolant Analysis.

S·O·S Coolant Analysis (Level 1)

A coolant analysis (Level 1) is a test of the properties of the coolant.

The following properties of the coolant are tested:

- Glycol concentration for freeze protection and boil protection
- Ability to protect from erosion and corrosion
- pH
- Conductivity
- Visual analysis
- Odor analysis

The results are reported, and appropriate recommendations are made.

Refer to the Maintenance Interval Schedule in this Operation and Maintenance Manual in order to find the maintenance interval for collecting the coolant samples.

S·O·S Coolant Analysis (Level 2)

Refill Capacities Fluid Recommendations

A coolant analysis (Level 2) is a comprehensive chemical evaluation of the coolant. This analysis is also a check of the overall condition of the inside of the cooling system.

The S·O·S Coolant Analysis has the following features:

- Full coolant analysis (Level 1)
- Identification of the source of metal corrosion and of contaminants
- Water hardness
- Identification of buildup of the impurities that cause corrosion
- Identification of buildup of the impurities that cause scaling

The results are reported, and appropriate recommendations are made.

Refer to the Maintenance Interval Schedule in this Operation and Maintenance Manual, "Cooling System Coolant Sample (Level 2) - Obtain" for the maintenance interval for collecting the coolant samples.

Testing the engine coolant is important to ensure that the engine is protected from internal cavitation and from corrosion. The analysis also tests the ability of the coolant to protect the engine from boiling and from freezing. The S·O·S Coolant Analysis can be done at your Caterpillar dealer. Caterpillar S·O·S Coolant Analysis is the best way to monitor the condition of your coolant and your cooling system. S·O·S Coolant Analysis is a program that is based on periodic samples.

Refer to Special Publication, SEBU6251, Caterpillar Commercial Diesel Engine Fluids Recommendations for additional information.

Maintenance Recommendations

i03648938

System Pressure Release

SMCS Code: 1250; 1300; 1350; 5050

Coolant System

WARNING

Pressurized system: Hot coolant can cause serious burn. To open cap, stop engine, wait until radiator is cool. Then loosen cap slowly to relieve the pressure.

The engine can have the ability to auto start. Ensure that the power supply is isolated before any service or repair is performed.

To relieve the pressure from the coolant system, turn off the engine. Allow the cooling system pressure cap to cool. Remove the cooling system pressure cap slowly in order to relieve pressure.

Fuel System

To relieve the pressure from the fuel system, turn off the engine.

High Pressure Fuel Lines

WARNING

Contact with high pressure fuel may cause fluid penetration and burn hazards. High pressure fuel spray may cause a fire hazard. Failure to follow these inspection, maintenance and service instructions may cause personal injury or death.

The high pressure fuel lines are the fuel lines that are between the high pressure fuel pump and the high pressure fuel manifold and the fuel lines that are between the fuel manifold and cylinder head. These fuel lines are different from fuel lines on other fuel systems.

This is because of the following differences:

- The high pressure fuel lines are constantly charged with high pressure.
- The internal pressures of the high pressure fuel lines are higher than other types of fuel system.

Before any service or repair is performed on the engine fuel lines, perform the following tasks:

1. Stop the engine.
2. Wait for 10 minutes.

Do not loosen the high pressure fuel lines in order to remove air from the fuel system.

Engine Oil

To relieve pressure from the lubricating system, turn off the engine.

i05354374

Welding on Engines with Electronic Controls

SMCS Code: 1000

NOTICE

Because the strength of the frame may decrease, some manufacturers do not recommend welding onto a chassis frame or rail. Consult the OEM of the equipment or your Caterpillar dealer regarding welding on a chassis frame or rail.

Proper welding procedures are necessary in order to avoid damage to the engines ECM, sensors, and associated components. When possible, remove the component from the unit and then weld the component. If removal of the component is not possible, the following procedure must be followed when you weld on a unit equipped with an Electronic Engine. The following procedure is considered to be the safest procedure to weld on a component. This procedure should provide a minimum risk of damage to electronic components.

NOTICE

Do not ground the welder to electrical components such as the ECM or sensors. Improper grounding can cause damage to the drive train bearings, hydraulic components, electrical components, and other components.

Clamp the ground cable from the welder to the component that will be welded. Place the clamp as close as possible to the weld. This will help reduce the possibility of damage.

Note: Perform the welding in areas that are free from explosive hazards.

1. Stop the engine. Turn the switched power to the OFF position.
2. Ensure that the fuel supply to the engine is turned off.

Maintenance Recommendations
Welding on Engines with Electronic Controls

3. Disconnect the negative battery cable from the battery. If a battery disconnect switch is provided, open the switch.
4. Disconnect all electronic components from the wiring harnesses. Include the following components:
 - Electronic components for the driven equipment
 - ECM
 - Sensors
 - Electronically controlled valves
 - Relays
 - Electric fuel pump
 - Aftertreatment ID module

NOTICE

Do not use electrical components (ECM or ECM sensors) or electronic component grounding points for grounding the welder.

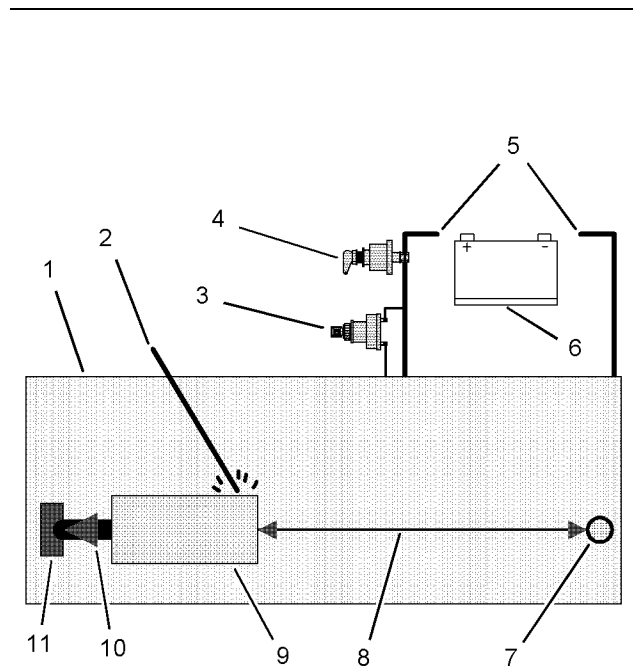

Illustration 59

g01075639

Use the example above. The current flow from the welder to the ground clamp of the welder will not damage any associated components.

- (1) Engine
- (2) Welding electrode
- (3) Keyswitch in the OFF position
- (4) Battery disconnect switch in the open position
- (5) Disconnected battery cables
- (6) Battery
- (7) Electrical/Electronic component
- (8) Minimum distance between the component that is being welded and any electrical/electronic component
- (9) The component that is being welded
- (10) Current path of the welder
- (11) Ground clamp for the welder

5. Connect the welding ground cable directly to the part that will be welded. Place the ground cable as close as possible to the weld in order to reduce the possibility of welding current damage to the following components. Bearings, hydraulic components, electrical components, and ground straps.

Note: If electrical/electronic components are used as a ground for the welder, or electrical/electronic components are located between the welder ground and the weld, current flow from the welder could severely damage the component.

6. Protect the wiring harness from welding debris and spatter.

7. Use standard welding practices to weld the materials.

i04807435

Severe Service Application

SMCS Code: 1000

An engine which operates outside of normal conditions is operating in a severe service application.

An engine that operates in a severe service application may need more frequent maintenance intervals in order to maximize the following conditions:

- Reliability
- Service life

The number of individual applications cause the impossibility of identifying all of the factors which may contribute to severe service operation. Consult your Caterpillar dealer for the unique maintenance that may be necessary for your engine.

An application is a severe service application if any of the following conditions apply:

Severe Environmental Factors

- Frequent operation in dirty air
- Frequent operation at an altitude which is above 1525 m (5000 ft)
- Frequent operation in ambient temperatures which are above 32° C (90° F)
- Frequent operation in ambient temperatures which are below 0° C (32° F)

Severe Operating Conditions

- Frequent operation with inlet air which has a corrosive content
- Operation with inlet air which has a combustible content
- Operation which is outside of the intended application
- Operation with a plugged fuel filter
- Extended operation at low idle (more than 20% of hours)
- Frequent cold starts at temperatures below 0° C (32° F)
- Frequent dry starts (starting after more than 72 hours of shutdown)
- Frequent hot shutdowns (shutting down the engine without the minimum of 2 minutes to 5 minutes of cool down time)
- Operation above the engine rated speed
- Operation below the peak torque speed
- Operating with fuel which does not meet the standards for distillate diesel fuel as stated in Special Publication, SEBU6250, Caterpillar Machine Fluids Recommendations, "Distillate Diesel Fuel"
- Operating with a blend of distillate fuel which contains more than 20 percent biodiesel

Improper Maintenance Procedures (Maintenance Procedures Which May Contribute to a Severe Service Application)

- Inadequate maintenance of fuel storage tanks from causes such as excessive water, sediment, and microorganism growth.
- Extending maintenance intervals beyond the recommended intervals
- Using fluids which are not recommended in Special Publication, SEBU6250, Caterpillar Machine Fluids Recommendations
- Extending maintenance intervals for changing the engine oil and engine coolant without S·O·S validation
- Extending maintenance intervals for changing air filters, oil filters, and fuel filters
- Failure to use a water separator
- Using filters which are not recommended by Special Publication, PEWJ0074, 2008 Cat Filter and Fluid Application Guide
- Storing the engine for more than 3 months but less than 1 yr (For information about engine storage, refer to Special Publication, SEHS9031, Storage Procedure for Caterpillar Products)

i05354411

Maintenance Interval Schedule

SMCS Code: 1000; 4450; 7500

When Required

“Battery - Replace”	89
“Battery or Battery Cable - Disconnect”	90
“Diesel Exhaust Fluid - Fill”	101
“Engine - Clean”	102
“Engine Air Cleaner Element (Dual Element) - Inspect/Clean/Replace”	102
“Engine Air Cleaner Element (Single Element) - Inspect/Replace”	105
“Fuel System - Prime”	115

Daily

“Coolant Level - Check”	97
“Driven Equipment - Check”	102
“Engine Air Cleaner Service Indicator - Inspect” ..	105
“Engine Air Precleaner - Check/Clean”	106
“Engine Oil Level - Check”	110
“Fuel System Primary Filter/Water Separator - Drain”	118
“Walk-Around Inspection”	128

Every Week

“Hoses and Clamps - Inspect/Replace”	120
--	-----

Every 50 Service Hours or Weekly

“Fuel Tank Water and Sediment - Drain”	120
--	-----

Every 250 Service Hours

“Coolant Sample (Level 1) - Obtain”	97
“Engine Oil Sample - Obtain”	110

Every 500 Service Hours

“Fan Clearance - Check”	113
-------------------------------	-----

Every 500 Service Hours or 1 Year

“Battery Electrolyte Level - Check”	89
“Cooling System Supplemental Coolant Additive (SCA) - Test/Add”	99

“Crankshaft Vibration Damper - Inspect”	100
“Engine Air Cleaner Element (Dual Element) - Inspect/Clean/Replace”	102
“Engine Air Cleaner Element (Single Element) - Inspect/Replace”	105
“Engine Oil and Filter - Change”	111
“Fuel Filter (In-Line) - Replace”	114
“Fuel System Primary Filter (Water Separator) Element - Replace”	116
“Fuel System Secondary Filter - Replace”	118
“Radiator - Clean”	125

Every 1000 Service Hours

“Belt Tensioner - Check”	90
“Belt - Inspect”	91
“Water Pump - Inspect”	129

Every 1500 Service Hours

“Engine Crankcase Breather Element - Replace” ..	106
--	-----

Every 2000 Service Hours

“Aftercooler Core - Inspect”	88
“Engine Mounts - Inspect”	109
“Starting Motor - Inspect”	126
“Turbocharger - Inspect”	126

Every Year

“Coolant Sample (Level 2) - Obtain”	98
---	----

Every 3000 Service Hours

“Alternator - Inspect”	88
“Alternator and Fan Belts - Replace”	89

Every 3000 Service Hours or 2 Years

“Coolant (DEAC) - Change”	91
---------------------------------	----

Every 4000 Service Hours

“Aftercooler Core - Clean/Test”	88
---------------------------------------	----

Every 5000 Service Hours

“Diesel Exhaust Fluid Filter - Clean/Replace”	101
“Injector (Diesel Exhaust Fluid) - Replace”	121

Every 6000 Service Hours or 3 Years

“Coolant Extender (ELC) - Add”96

Every 12 000 Service Hours or 6 Years

“Coolant (ELC) - Change”94

Overhaul

“Overhaul Considerations” 123

i01807350

Aftercooler Core - Clean/Test (Air-To-Air Aftercooler)

SMCS Code: 1064-070; 1064-081

The air-to-air aftercooler is OEM installed in many applications. Please refer to the OEM specifications for information that is related to the aftercooler.

i04380914

Aftercooler Core - Inspect

SMCS Code: 1064-040

Note: Adjust the frequency of cleaning according to the effects of the operating environment.

Inspect the aftercooler for these items: damaged fins, corrosion, dirt, grease, insects, leaves, oil and other debris. Clean the aftercooler, if necessary.

For air-to-air aftercoolers, use the same methods that are used for cleaning radiators.



WARNING

Personal injury can result from air pressure.

Personal injury can result without following proper procedure. When using pressure air, wear a protective face shield and protective clothing.

Maximum air pressure at the nozzle must be less than 205 kPa (30 psi) for cleaning purposes.

Pressurized air is the preferred method for removing loose debris. Direct the air in the opposite direction of the fans air flow. Hold the nozzle approximately 6 mm (.25 inch) away from the fins. Slowly move the air nozzle in a direction that is parallel with the tubes. The pressurized air will remove debris that is between the tubes.

Pressurized water may also be used for cleaning. The maximum water pressure for cleaning purposes must be less than 275 kPa (40 psi). Use pressurized water in order to soften mud. Clean the core from both sides.

Use a degreaser and steam for removal of oil and grease. Clean both sides of the core. Wash the core with detergent and hot water. Thoroughly rinse the core with clean water.

After cleaning, start the engine and accelerate the engine to high idle rpm. This will help in the removal of debris and drying of the core. Stop the engine. Use a light bulb behind the core in order to inspect the core for cleanliness. Repeat the cleaning, if necessary.

Inspect the fins for damage. Bent fins may be opened with a “comb”.

Note: If parts of the aftercooler system are repaired or replaced, a leak test is highly recommended. For more information, refer to OEM specification for the aftercooler.

Inspect these items for good condition: welds, mounting brackets, air lines, connections, clamps and seals. Make repairs, if necessary.

i03641972

Alternator - Inspect

SMCS Code: 1405-040

Caterpillar recommends a scheduled inspection of the alternator. Inspect the alternator for loose connections and proper battery charging. Inspect the ammeter (if equipped) during engine operation in order to ensure proper battery performance and/or proper performance of the electrical system. Make repairs, as required.

Check the alternator and the battery charger for proper operation. If the batteries are properly charged, the ammeter reading should be very near zero. All batteries should be kept charged. The batteries should be kept warm because temperature affects the cranking power of the battery. If the battery is too cold, the battery will not crank the engine.

When the engine is not run for long periods of time or if the engine is run for short periods, the batteries may not fully charge. A battery with a low charge will freeze more easily than a battery with a full charge.

i02320208

Alternator and Fan Belts - Replace

SMCS Code: 1357-510

Refer to Disassembly and Assembly Manual, "Alternator Belt - Remove and Install".

i05425759

Battery - Replace

SMCS Code: 1401-510

WARNING

Batteries give off combustible gases which can explode. A spark can cause the combustible gases to ignite. This can result in severe personal injury or death.

Ensure proper ventilation for batteries that are in an enclosure. Follow the proper procedures in order to help prevent electrical arcs and/or sparks near batteries. Do not smoke when batteries are serviced.

WARNING

The battery cables or the batteries should not be removed with the battery cover in place. The battery cover should be removed before any servicing is attempted.

Removing the battery cables or the batteries with the cover in place may cause a battery explosion resulting in personal injury.

1. Switch the engine to the OFF position. Remove all electrical loads.

Note: After the engine has stopped, allow 2 minutes in order for the diesel exhaust fluid lines to be purged before disconnecting the power.

2. Turn off any battery chargers. Disconnect any battery chargers.
3. Ensure that the battery disconnect switch is in the OFF position.
4. Disconnect the NEGATIVE "-" cable from the NEGATIVE "-" battery terminal.
5. Disconnect the POSITIVE "+" cable from the POSITIVE "+" battery terminal.

Note: Always recycle a battery. Never discard a battery. Dispose of used batteries to an appropriate recycling facility.

6. Remove the used battery.

7. Install the new battery.

Note: Before the cables are connected, ensure that the battery disconnect switch is in the OFF position.

8. Connect the POSITIVE "+" cable to the POSITIVE "+" battery terminal.

9. Connect the NEGATIVE "-" cable to the NEGATIVE "-" battery terminal.

10. Turn the battery disconnect switch to the ON position.

i02724529

Battery Electrolyte Level - Check

SMCS Code: 1401-535-FLV

When the engine is not run for long periods of time or when the engine is run for short periods, the batteries may not fully recharge. Ensure a full charge in order to help prevent the battery from freezing. If batteries are properly charged, ammeter reading should be very near zero, when the engine is in operation.

WARNING

All lead-acid batteries contain sulfuric acid which can burn the skin and clothing. Always wear a face shield and protective clothing when working on or near batteries.

1. Remove the filler caps. Maintain the electrolyte level to the "FULL" mark on the battery.

If the addition of water is necessary, use distilled water. If distilled water is not available use clean water that is low in minerals. Do not use artificially softened water.

2. Check the condition of the electrolyte with the 245 - 5829 Coolant Battery Tester Refractometer.
3. Keep the batteries clean.

Clean the battery case with one of the following cleaning solutions:

- Use a solution of 0.1 kg (0.2 lb) baking soda and 1 L (1 qt) of clean water.
- Use a solution of ammonium hydroxide .

Thoroughly rinse the battery case with clean water.

Use a fine grade of sandpaper to clean the terminals and the cable clamps. Clean the items until the surfaces are bright or shiny. DO NOT remove material excessively. Excessive removal of material can cause the clamps to not fit properly. Coat the clamps and the terminals with 5N-5561 Silicone Lubricant, petroleum jelly or MPGM.

i05424317

Battery or Battery Cable - Disconnect

SMCS Code: 1401; 1402-029

WARNING

The battery cables or the batteries should not be removed with the battery cover in place. The battery cover should be removed before any servicing is attempted.

Removing the battery cables or the batteries with the cover in place may cause a battery explosion resulting in personal injury.

1. Turn the start switch to the OFF position. Turn the ignition switch (if equipped) to the OFF position and remove the key and all electrical loads.

Note: After the engine has stopped, allow 2 minutes in order for the diesel exhaust fluid lines to be purged before disconnecting the power.

2. Disconnect the negative battery terminal. Ensure that the cable cannot contact the terminal. When four 12 V batteries are involved, 2 negative connections must be disconnected.
3. Remove the positive connection.
4. Clean all disconnected connection and battery terminals.
5. Use a fine grade of sandpaper to clean the terminals and the cable clamps. Clean the items until the surfaces are bright or shiny. DO NOT remove material excessively. Excessive removal of material can cause the clamps to fit incorrectly. Coat the clamps and the terminals with a suitable silicone lubricant or petroleum jelly.
6. Tape the cable connections in order to help prevent accidental starting.
7. Proceed with necessary system repairs.

8. In order to connect the battery, connect the positive connection before the negative connector.

i04907925

Belt Tensioner - Check

SMCS Code: 1358-535

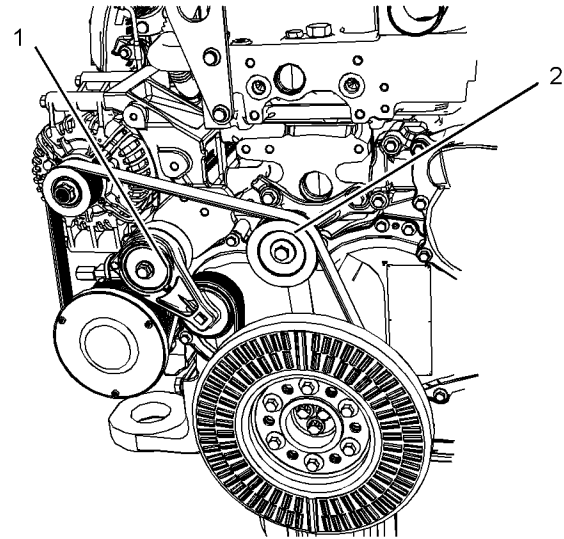

Illustration 60

g03074016

Typical example

Remove the belt. Refer to Disassembly and Assembly, "Alternator Belt - Remove and Install".

Ensure that the belt tensioner is securely installed. Visually inspect the belt tensioner (1) for damage. Check that the pulley on the tensioner rotates freely and that the bearing is not loose. Some engines have an idler pulley (2). Ensure that the idler pulley is securely installed. Visually inspect the idler pulley for damage. Ensure that the idler pulley can rotate freely and that the bearing is not loose. If necessary, replace damaged components.

Install the belt. Refer to Disassembly and Assembly, "Alternator Belt - Remove and Install".

i04907868

Belt - Inspect

SMCS Code: 1357-040; 1357; 1397-040; 1397

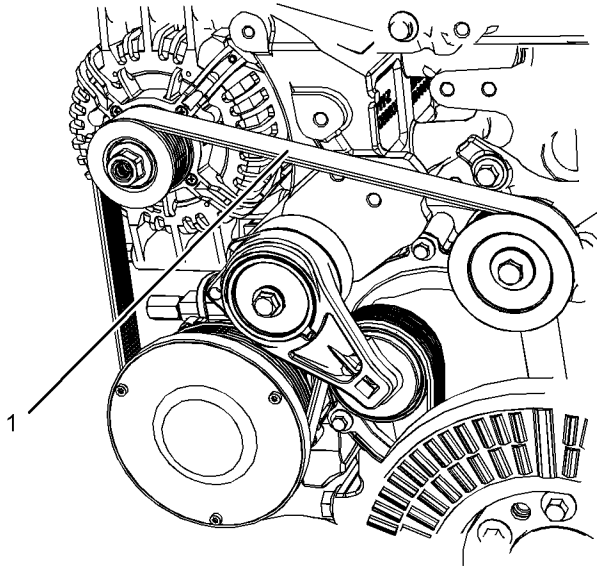

Illustration 61

g03073936

Typical example

To maximize the engine performance, inspect the belt (1) for wear and for cracking. Replace the belt if the belt is worn or damaged.

- Inspect the belt for cracks, splits, glazing, grease, displacement of the cord and evidence of fluid contamination.

The belt must be replaced if the following conditions are present.

- The belt has a crack in more than one rib.
- More than one section of the belt is displaced in one rib of a maximum length of 50.8 mm (2 inch).

To replace the belt, refer to Disassembly and Assembly, "Alternator Belt - Remove and Install". If necessary, replace the belt tensioner. Refer to Disassembly and Assembly, "Alternator Belt - Remove and Install" for the correct procedure.

i05425761

Coolant (DEAC) - Change

SMCS Code: 1350-070; 1395-044

Clean the cooling system and flush the cooling system before the recommended maintenance interval if the following conditions exist:

- The engine overheats frequently.
- Foaming is observed.
- The oil has entered the cooling system and the coolant is contaminated.
- The fuel has entered the cooling system and the coolant is contaminated.

NOTICE

Use of commercially available cooling system cleaners may cause damage to cooling system components. Use only cooling system cleaners that are approved for Caterpillar engines.

NOTICE

When any servicing or repair of the engine cooling system is performed, the procedure must be performed with the engine on level ground. Level ground will allow you to check accurately the coolant level. This procedure will also help in avoiding the risk of introducing an air lock into the coolant system.

Note: Inspect the water pump and the water temperature regulator after the cooling system has been drained. This inspection is a good opportunity to replace the water pump, the water temperature regulator, and the hoses, if necessary.

Drain

WARNING

Pressurized System: Hot coolant can cause serious burns. To open the cooling system filler cap, stop the engine and wait until the cooling system components are cool. Loosen the cooling system pressure cap slowly in order to relieve the pressure.

1. Stop the engine and allow the engine to cool. Loosen the cooling system filler cap slowly in order to relieve any pressure. Remove the cooling system filler cap.

Note: Refer to Operation and Maintenance Manual, "General Hazard Information" for information on Containing Fluid Spillage.

Maintenance Recommendations

Coolant (DEAC) - Change

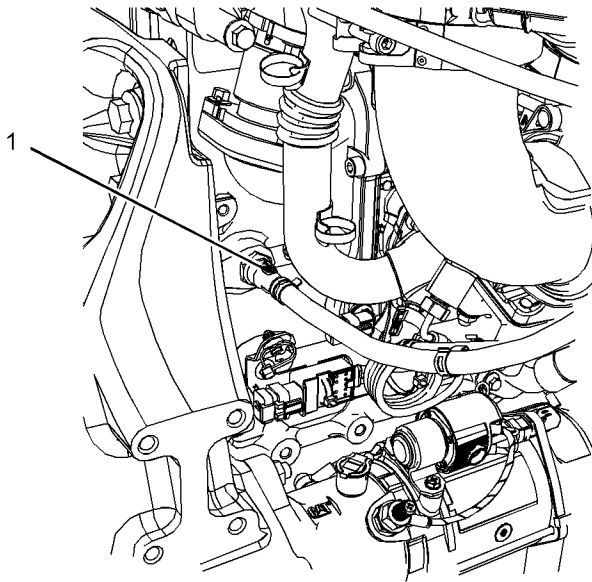

Illustration 62

g03075756

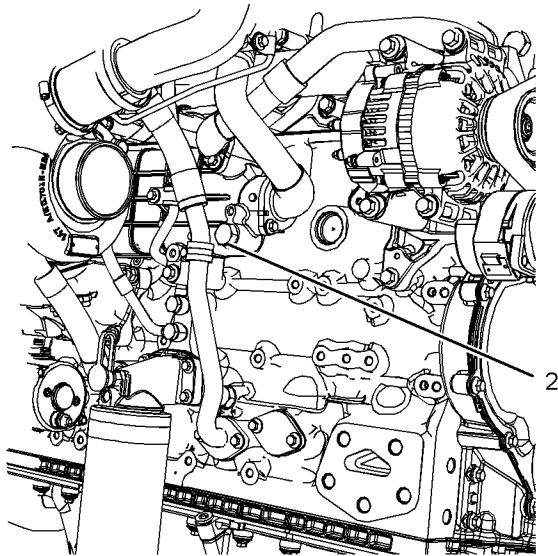

Illustration 63

g02350785

2. Remove connection hose (1) on the engine. Also remove the drain plug (2). Open the drain cock or remove the drain plug on the radiator.

Allow the coolant to drain into a suitable container.

3. Properly dispose of the drained material. Obey local regulations for the disposal of the material.

NOTICE

Dispose of used engine coolant properly or recycle. Various methods have been proposed to reclaim used coolant for reuse in engine cooling systems. The full distillation procedure is the only method acceptable by Caterpillar to reclaim the used coolant.

Alternative Drain Plug

The cylinder coolant can be drained from the plug below the oil cooler. Refer to illustration 64. If the alternative drain plug (3) is removed, the O ring seal must be replaced. Tighten the drain plug to a torque of 35 N·m (25 lb ft).

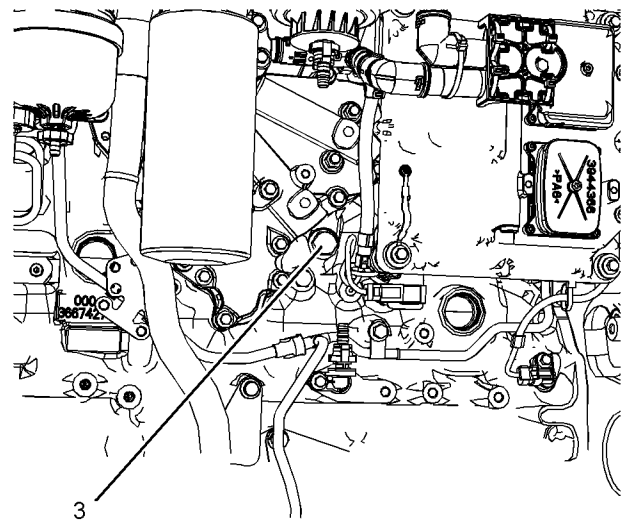

Illustration 64

g03081697

Flush

1. Flush the cooling system with clean water in order to remove any debris.
2. Install connection hose. Clean the drain plugs. Install the drain plugs and tighten securely.

NOTICE

Do not fill the cooling system faster than 5 L (1.3 US gal) per minute to avoid air locks.

Cooling system air locks may result in engine damage.

3. Fill the cooling system with a mixture of clean water and Caterpillar Fast Acting Cooling System Cleaner. Add 0.5 L (1 pt) of cleaner per 15 L (4 US gal) of the cooling system capacity. Install the cooling system filler cap.

4. Start and run the engine at low idle for a minimum of 30 minutes. The coolant temperature should be at least 82 °C (180 °F).

NOTICE

Improper or incomplete rinsing of the cooling system can result in damage to copper and other metal components.

To avoid damage to the cooling system, make sure to completely flush the cooling system with clear water. Continue to flush the system until all signs of the cleaning agent are gone.

5. Stop the engine and allow the engine to cool. Loosen the cooling system filler cap slowly in order to relieve any pressure. Remove the cooling system filler cap. Remove the connection hose or remove the cooling system drain plugs. Allow the water to drain. Flush the cooling system with clean water. Install the connection hose.
6. The drain plug O rings on the engine block must be replaced. Clean the drain plugs and install new O ring seal. Install the drain plugs and tighten to a torque of 35 N·m (25 lb ft).

Cooling Systems with Heavy Deposits or Plugging

Note: For the following procedure to be effective, there must be some active flow through the cooling system components.

1. Flush the cooling system with clean water in order to remove any debris.
2. Install the connection hose. Clean the drain plugs. Install the drain plugs and tighten securely.

NOTICE

Do not fill the cooling system faster than 5 L (1.3 US gal) per minute to avoid air locks.

Cooling system air locks may result in engine damage.

3. Fill the cooling system with a mixture of clean water and Caterpillar Fast Acting Cooling System Cleaner. Add 0.5 L (1 pt) of cleaner per 3.8 to 7.6 L (1 to 2 US gal) of the cooling system capacity. Install the cooling system filler cap.
4. Start and run the engine at low idle for a minimum of 90 minutes. The coolant temperature should be at least 82 °C (180 °F).

NOTICE

Improper or incomplete rinsing of the cooling system can result in damage to copper and other metal components.

To avoid damage to the cooling system, make sure to completely flush the cooling system with clear water. Continue to flush the system until all signs of the cleaning agent are gone.

5. Stop the engine and allow the engine to cool. Loosen the cooling system filler cap slowly in order to relieve any pressure. Remove the cooling system filler cap. Open the drain valve (if equipped) or remove the cooling system drain plugs. Allow the water to drain. Flush the cooling system with clean water. Install the connection hose.
6. The drain plug O rings on the engine block must be replaced. Clean the drain plugs and install new O ring seal. Install the drain plugs and tighten to a torque of 35 N·m (25 lb ft).

Fill

NOTICE

Do not fill the cooling system faster than 5 L (1.3 US gal) per minute to avoid air locks.

Cooling system air locks may result in engine damage.

1. Fill the cooling system with the coolant/antifreeze. Refer to this Operation and Maintenance Manual, "Refill Capacities and Recommendations" topic (Maintenance Section) for more information on cooling system specifications. Do not install the cooling system filler cap.
2. Start and run the engine at low idle. Increase the engine rpm to high idle. Operate the engine in order to open the engine thermostat. This operation will allow any air in the system to be purged. Decrease the engine speed to low idle. Stop the engine.
3. Maintain the coolant level at the maximum mark that is correct for your application.

4. Clean the cooling system filler cap. Inspect the gasket that is on the cooling system filler cap. If the gasket that is on the cooling system filler cap is damaged, discard the old cooling system filler cap and install a new cooling system filler cap. If the gasket that is on the cooling system filler cap is not damaged, perform a pressure test. A 9S-8140 Pressurizing Pump is used to perform the pressure test. The correct pressure for the cooling system filler cap is stamped on the face of the cooling system filler cap. If the cooling system filler cap does not retain the correct pressure, install a new cooling system filler cap.
5. Start the engine. Inspect the cooling system for leaks and for the correct operating temperature.

i05360509

Coolant (ELC) - Change

SMCS Code: 1350-070; 1395-044

Clean the cooling system and flush the cooling system before the recommended maintenance interval if the following conditions exist:

- The engine overheats frequently.
- Foaming is observed.
- The oil has entered the cooling system and the coolant is contaminated.
- The fuel has entered the cooling system and the coolant is contaminated.

Note: When the cooling system is cleaned, only clean water is needed when the ELC is drained and replaced.

Note: Inspect the water pump and the water temperature regulator after the cooling system has been drained. Replace the water pump, the water temperature regulator, and the hoses, if necessary.

NOTICE

Service or repair of the engine cooling system must be performed on level ground. The engine must be level in order to check the coolant level. The engine must be level in order to avoid the risk of introducing an air lock into the coolant system.

Drain

WARNING

Pressurized System: Hot coolant can cause serious burns. To open the cooling system filler cap, stop the engine and wait until the cooling system components are cool. Loosen the cooling system pressure cap slowly in order to relieve the pressure.

1. Stop the engine and allow the engine to cool. Loosen the cooling system filler cap slowly in order to relieve any pressure. Remove the cooling system filler cap.

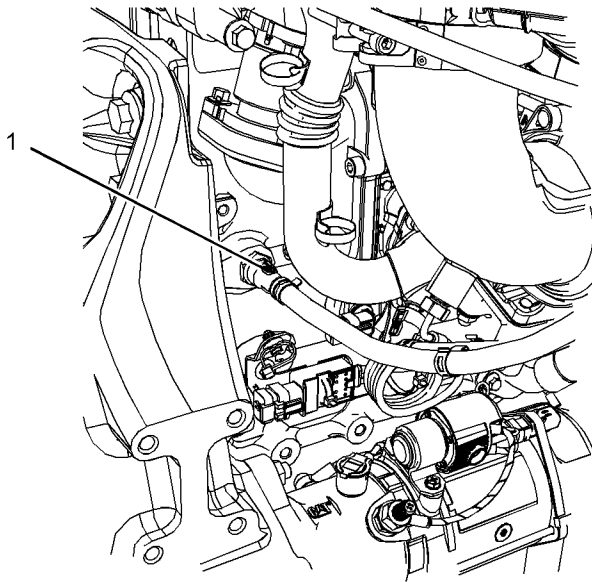

Illustration 65

g03075756

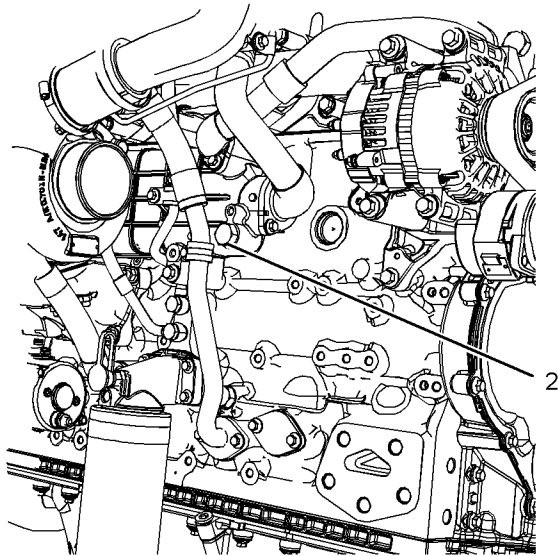

Illustration 66

g02350785

2. Remove connection hose (1) on the engine. Also remove the drain plug (2). Open the drain cock or remove the drain plug on the radiator.

Allow the coolant to drain.

NOTICE

Dispose of used engine coolant properly or recycle. Various methods have been proposed to reclaim used coolant for reuse in engine cooling systems. The full distillation procedure is the only method acceptable by Caterpillar to reclaim the used coolant.

For information regarding the disposal and the recycling of used coolant, consult your Caterpillar dealer or consult Dealer Service Tools .

Flush

1. Flush the cooling system with clean water in order to remove any debris.
2. Install the connection hose. Clean the drain plugs. Install the drain plugs. Refer to Torque Specifications, SENR3130 for more information on the correct torques.

NOTICE

Do not fill the cooling system faster than 5 L (1.3 US gal) per minute to avoid air locks.

Cooling system air locks may result in engine damage.

3. Fill the cooling system with clean water. Install the cooling system filler cap.
4. Start and run the engine at low idle until the temperature reaches 49 to 66 °C (120 to 150 °F).
5. Stop the engine and allow the engine to cool. Loosen the cooling system filler cap slowly in order to relieve any pressure. Remove the cooling system filler cap. Remove the connection hose and remove the cooling system drain plugs. Allow the water to drain. Flush the cooling system with clean water. Install the connection hose. Clean the drain plugs. Install the drain plugs. Refer to Torque Specifications, SENR3130 for more information on the correct torques.

Fill

NOTICE

Do not fill the cooling system faster than 5 L (1.3 US gal) per minute to avoid air locks.

Cooling system air locks may result in engine damage.

1. Fill the cooling system with Extended Life Coolant (ELC). Refer to this Operation and Maintenance Manual, "Refill Capacities and Recommendations" topic (Maintenance Section) for more information on cooling system specifications. Do not install the cooling system filler cap.

Maintenance Recommendations

Coolant Extender (ELC) - Add

2. Start and run the engine at low idle. Increase the engine rpm to high idle. Operate the engine in order to open the engine thermostat. An open thermostat will allow any air in the system to be purged. Decrease the engine speed to low idle. Stop the engine.
3. Maintain the coolant level at the maximum mark that is correct for your application.
4. Clean the cooling system filler cap. Inspect the gasket that is on the cooling system filler cap. If the gasket that is on the cooling system filler cap is damaged, discard the old cooling system filler cap and install a new cooling system filler cap. If the gasket that is on the cooling system filler cap is not damaged, use a 9S-8140 Pressurizing Pump in order to pressure test the cooling system filler cap. The correct pressure for the cooling system filler cap is stamped on the face of the cooling system filler cap. If the cooling system filler cap does not retain the correct pressure, install a new cooling system filler cap.
5. Start the engine. Inspect the cooling system for leaks and for proper operating temperature.

i04913503

Coolant Extender (ELC) - Add

SMCS Code: 1352-544-NL

Cat ELC (Extended Life Coolant) does not require the frequent additions of any supplemental cooling additives which are associated with the present conventional coolants. The Cat ELC Extender only needs adding once.

NOTICE

Use only Cat Extended Life Coolant (ELC) Extender with Cat ELC.

Do NOT use conventional supplemental coolant additive (SCA) with Cat ELC. Mixing Cat ELC with conventional coolants and/or conventional SCA reduces the Cat ELC service life.

Check the cooling system only when the engine is stopped and cool.

WARNING

Personal injury can result from hot coolant, steam and alkali.

At operating temperature, engine coolant is hot and under pressure. The radiator and all lines to heaters or the engine contain hot coolant or steam. Any contact can cause severe burns.

Remove cooling system pressure cap slowly to relieve pressure only when engine is stopped and cooling system pressure cap is cool enough to touch with your bare hand.

Do not attempt to tighten hose connections when the coolant is hot, the hose can come off causing burns.

Cooling System Coolant Additive contains alkali. Avoid contact with skin and eyes.

NOTICE

Care must be taken to ensure that fluids are contained during performance of inspection, maintenance, testing, adjusting, and repair of the product. Be prepared to collect the fluid with suitable containers before opening any compartment or disassembling any component containing fluids.

Refer to Special Publication, NENG2500, "Cat Dealer Service Tool Catalog" or refer to Special Publication, PECJ0003, "Cat Shop Supplies and Tools Catalog" for tools and supplies suitable to collect and contain fluids on Cat products.

Dispose of all fluids according to local regulations and mandates.

NOTICE

When any servicing or repair of the engine cooling system is performed, the procedure must be performed with the engine on level ground. This procedure will allow you to check accurately the coolant level. This procedure will also help in avoiding the risk of introducing an air lock into the coolant system.

1. Loosen the cooling system filler cap slowly in order to relieve pressure. Remove the cooling system filler cap.
2. If necessary, drain enough coolant from the cooling system in order to add the Cat ELC Extender .
3. Add Cat ELC Extender according to the requirements for your engines cooling system capacity. Refer to the Operation and Maintenance Manual, "Refill Capacities and Recommendations" article for more information.

4. Clean the cooling system filler cap. Inspect the gaskets on the cooling system filler cap. Replace the cooling system filler cap if the gaskets are damaged. Install the cooling system filler cap.

i05436397

Coolant Level - Check

SMCS Code: 1395-082

WARNING

Pressurized System: Hot coolant can cause serious burns. To open the cooling system filler cap, stop the engine and wait until the cooling system components are cool. Loosen the cooling system pressure cap slowly in order to relieve the pressure.

Check the coolant level when the engine is stopped and cool.

NOTICE

When any servicing or repair of the engine cooling system is performed, the procedure must be performed with the engine on level ground. This procedure will allow you to check accurately the coolant level. This procedure will also help in avoiding the risk of introducing an air lock into the coolant system.

1. Remove the cooling system filler cap slowly in order to relieve pressure.
2. Maintain the coolant level at the maximum mark that is correct for your application. If the engine is equipped with a sight glass, maintain the coolant level to the correct level in the sight glass.

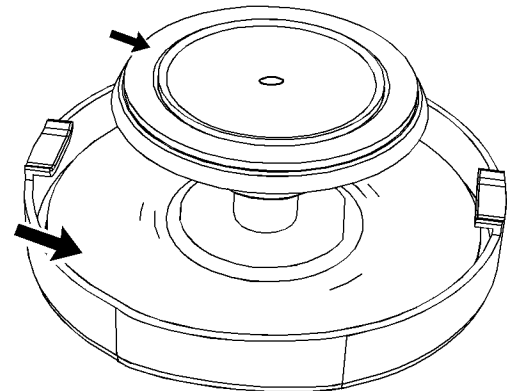

Illustration 67

g02590196

Typical filler cap gaskets

3. Clean the cooling system filler cap and check the condition of the filler cap gaskets. Replace the cooling system filler cap if the filler cap gaskets are damaged. Reinstall the cooling system filler cap.
4. Inspect the cooling system for leaks.

Note: The Diesel Exhaust Fluid (DEF) tank requires coolant flow around the tank. The Coolant Diverter Valve (CDV) will turn the flow on or off. If the coolant system has been filled with the CDV in the closed position, coolant level will drop because of the opening of the CDV.

i04913603

Coolant Sample (Level 1) - Obtain

SMCS Code: 1350-008; 1395-008; 1395-554; 7542

Note: Obtaining a Coolant Sample (Level 1) is optional if the cooling system is filled with Cat ELC (Extended Life Coolant). Cooling systems filled with Cat ELC should have a Coolant Sample (Level 2) that is obtained at the recommended interval as stated in the maintenance interval schedule.

Note: Obtain a Coolant Sample (Level 1) if the cooling system is filled with any other coolant instead of Cat ELC including the following coolants:

Maintenance Recommendations

Coolant Sample (Level 2) - Obtain

- Commercial long life coolants that meet the Caterpillar Engine Coolant Specification -1 (Caterpillar EC-1)
- Cat DEAC (Diesel Engine Antifreeze/Coolant)
- Commercial heavy-duty coolant/antifreeze

Table 18

Recommended Interval		
Type of Coolant	Level 1	Level 2
Cat DEAC	Every 250 service hours	Every year ⁽¹⁾
Conventional heavy duty-coolant		
Commercial coolant that meets the requirements of the Caterpillar EC-1 standard		
Cat ELC or conventional EC-1 coolant	Optional	Every year ⁽¹⁾

⁽¹⁾ The Level 2 Coolant Analysis should be performed sooner if a problem is suspected or identified.

NOTICE

Always use a designated pump for oil sampling, and use a separate designated pump for coolant sampling. Using the same pump for both types of samples may contaminate the samples that are being drawn. This contaminate may cause a false analysis and an incorrect interpretation that could lead to concerns by both dealers and customers.

Note: Level 1 results may indicate a need for Level 2 Analysis.

Obtain the sample of the coolant as close as possible to the recommended sampling interval. In order to receive the full effect of S·O·S analysis, establish a consistent trend of data. In order to establish a pertinent history of data, perform consistent samplings that are evenly spaced. Supplies for collecting samples can be obtained from your Caterpillar dealer.

Use the following guidelines for proper sampling of the coolant:

- Complete the information on the label for the sampling bottle before you begin to take the samples.
- Keep the unused sampling bottles stored in plastic bags.
- Obtain coolant samples directly from the coolant sample port. You should not obtain the samples from any other location.
- Keep the lids on empty sampling bottles until you are ready to collect the sample.
- Place the sample in the mailing tube immediately after obtaining the sample in order to avoid contamination.
- Never collect samples from expansion bottles.
- Never collect samples from the drain for a system.

Submit the sample for Level 1 analysis.

For additional information about coolant analysis, see this Operation and Maintenance Manual, "Refill Capacities and Recommendations" or consult your Caterpillar dealer.

i04913805

Coolant Sample (Level 2) - Obtain

SMCS Code: 1350-008; 1395-008; 1395-554; 7542

NOTICE

Always use a designated pump for oil sampling, and use a separate designated pump for coolant sampling. Using the same pump for both types of samples may contaminate the samples that are being drawn. This contaminate may cause a false analysis and an incorrect interpretation that could lead to concerns by both dealers and customers.

NOTICE

Care must be taken to ensure that fluids are contained during performance of inspection, maintenance, testing, adjusting and repair of the product. Be prepared to collect the fluid with suitable containers before opening any compartment or disassembling any component containing fluids.

Refer to Special Publication, NENG2500, "Caterpillar Dealer Service Tool Catalog" or refer to Special Publication, PECJ0003, "Caterpillar Shop Supplies and Tools Catalog" for tools and supplies suitable to collect and contain fluids on Caterpillar products.

Dispose of all fluids according to local regulations and mandates.

Refer to Operation and Maintenance Manual, "Cooling System Coolant Sample (Level 1) - Obtain" for the guidelines for proper sampling of the coolant.

Submit the sample for Level 2 analysis.

For additional information about coolant analysis, see Special Publication, SEBU6251, "Caterpillar Commercial Diesel Engines Fluids Recommendations" or consult your Caterpillar dealer.

i03644817

Cooling System Supplemental Coolant Additive (SCA) - Test/Add

SMCS Code: 1352-045; 1395-081

 **WARNING**

Cooling system coolant additive contains alkali. To help prevent personal injury, avoid contact with the skin and the eyes. Do not drink cooling system coolant additive.

Note: Test the concentration of the Supplemental Coolant Additive (SCA) or test the SCA concentration as part of an S·O·S Coolant Analysis.

Test for SCA Concentration

Coolant and SCA

NOTICE

Do not exceed the recommended six percent supplemental coolant additive concentration.

Use the 8T - 5296 Coolant Conditioner Test Kit or use the 4C - 9301 Coolant Conditioner Test Kit in order to check the concentration of the SCA. Refer to this Operation and Maintenance Manual, "Refill Capacities and Recommendations" for more information.

Water and SCA

NOTICE

Do not exceed the recommended eight percent supplemental coolant additive concentration.

Test the concentration of the SCA with the 8T - 5296 Coolant Conditioner Test Kit. Refer to the Special Publication, SEBU6251, Caterpillar Commercial Diesel Engine Fluids Recommendations for more information.

S·O·S Coolant Analysis

S·O·S coolant samples can be analyzed at your Caterpillar dealer. S·O·S Coolant Analysis is a program that is based on periodic samples.

Level 1

Level 1 is a basic analysis of the coolant. The following items are tested:

- Glycol Concentration
- Concentration of SCA
- pH
- Conductivity

The results are reported, and recommendations are made according to the results. Consult your Caterpillar dealer for information on the benefits of managing your equipment with an S·O·S Coolant Analysis.

Level 2

This level coolant analysis is recommended when the engine is overhauled. Refer to this Operations and Maintenance Manual, "Overhaul Considerations" for further information.

Add the SCA, If Necessary

NOTICE

Do not exceed the recommended amount of supplemental coolant additive concentration. Excessive supplemental coolant additive concentration can form deposits on the higher temperature surfaces of the cooling system, reducing the engine's heat transfer characteristics. Reduced heat transfer could cause cracking of the cylinder head and other high temperature components. Excessive supplemental coolant additive concentration could also result in radiator tube blockage, overheating, and/or accelerated water pump seal wear. Never use both liquid supplemental coolant additive and the spin-on element (if equipped) at the same time. The use of those additives together could result in supplemental coolant additive concentration exceeding the recommended maximum.

WARNING

Pressurized System: Hot coolant can cause serious burns. To open the cooling system filler cap, stop the engine and wait until the cooling system components are cool. Loosen the cooling system pressure cap slowly in order to relieve the pressure.

NOTICE

When any servicing or repair of the engine cooling system is performed the procedure must be performed with the engine on level ground. This will allow you to accurately check the coolant level. This will also help in avoiding the risk of introducing an air lock into the coolant system.

1. Slowly loosen the cooling system filler cap in order to relieve the pressure. Remove the cooling system filler cap.

Note: Always discard drained fluids according to local regulations.

2. If necessary, drain some coolant from the cooling system into a suitable container in order to allow space for the extra SCA.
3. Add the proper amount of SCA. Refer to the Special Publication, SEBU6251, Caterpillar Commercial Diesel Engines Fluids Recommendations for more information on SCA requirements.

4. Clean the cooling system filler cap. Inspect the gaskets of the cooling system filler cap. If the gaskets are damaged, replace the old cooling system filler cap with a new cooling system filler cap. Install the cooling system filler cap.

i03634651

Crankshaft Vibration Damper - Inspect

SMCS Code: 1205-040

Viscous Damper

The viscous damper has a inertia weight that is located inside a fluid filled case. The inertia weight moves in the case in order to limit torsional vibration.

Visually inspect the crankshaft damper. Ensure that the cooling fins (1) on the crankshaft damper are clean and free from dirt.

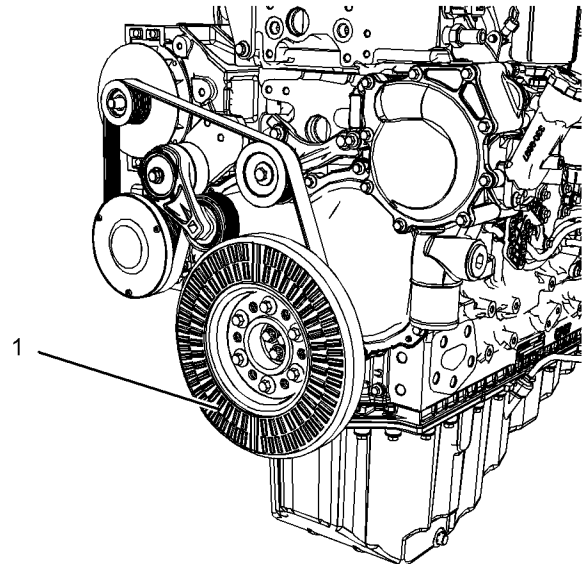

Illustration 68

g01950241

Typical example

Inspect the damper and replace the damper for any of the following reasons:

- The damper is dented, cracked, or leaking.

For information on removal of the crankshaft damper, refer to Disassembly and Assembly, "Vibration Damper and Pulley - Remove and Install".

i05413412

Diesel Exhaust Fluid - Fill

SMCS Code: 108K-544

Refer to the original equipment manufacture information for the Diesel Exhaust Fluid (DEF) tank capacity.

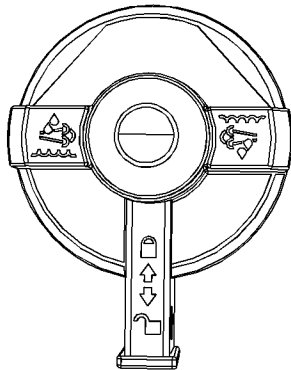

Illustration 69

g03379943

Lockable type DEF Filler cap

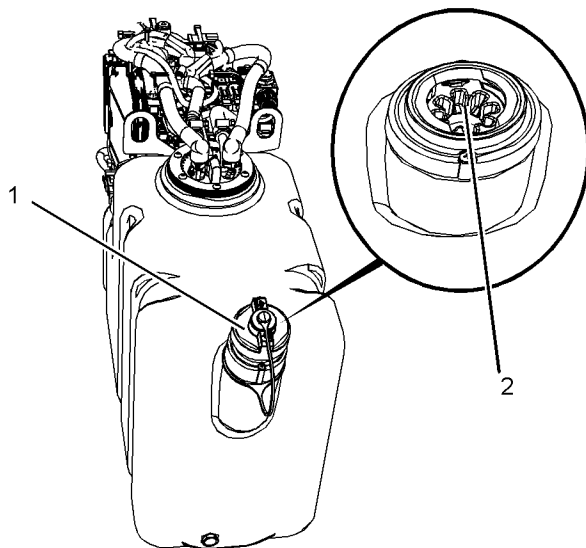

Illustration 70

g03417998

Typical example

1. Ensure that the DEF cap (1) and the surrounding area is clean and free from dirt.
2. Remove the DEF cap from the tank.
3. Fill the tank with the required amount of DEF. Ensure that dirt is not introduced into the tank during filling. Do not over fill the tank. The DEF may require room for expansion.

4. The opening on the DEF tank (2) is a special diameter. Ensure that the correct nozzle is used when filling the DEF tank.
5. Install the DEF cap.

i04928595

Diesel Exhaust Fluid Filter - Clean/Replace

SMCS Code: 108K-070-FI; 108K-510-FI

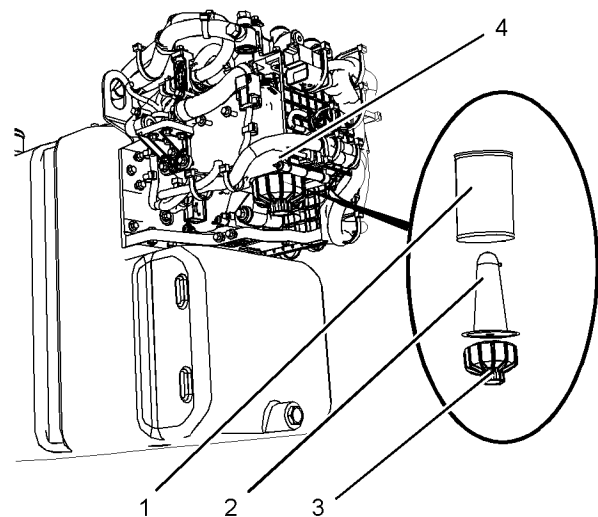

Illustration 71

g03097598

1. Ensure that the area around the Diesel Exhaust Fluid (DEF) filter is clean and free from dirt. Use a 27mm Bi-Hex socket in order to remove filter cap (3).
2. Remove the expansion device (2). Use tool supplied with new filter element in order to remove expansion device. Remove filter element (1) from main body (4).
3. Install new filter element (1) into main body (4). Install expansion device (2) into filter element (1). Install filter cap (3) and tighten cap to 20 N·m (15 lb ft).

i00174798

Driven Equipment - Check

SMCS Code: 3279-535

Refer to the OEM specifications for more information on the following maintenance recommendations for the driven equipment:

- Inspection
- Adjustment
- Lubrication
- Other maintenance recommendations

Perform any maintenance for the driven equipment which is recommended by the OEM.

i03991933

Engine - Clean

SMCS Code: 1000-070

WARNING

Personal injury or death can result from high voltage.

Moisture can create paths of electrical conductivity.

Make sure that the electrical system is OFF. Lock out the starting controls and tag the controls "DO NOT OPERATE" .

NOTICE

Accumulated grease and oil on an engine is a fire hazard. Keep the engine clean. Remove debris and fluid spills whenever a significant quantity accumulates on the engine.

Periodic cleaning of the engine is recommended. Steam cleaning the engine will remove accumulated oil and grease. A clean engine provides the following benefits:

- Easy detection of fluid leaks
- Maximum heat transfer characteristics
- Ease of maintenance

Note: Caution must be used in order to prevent electrical components from being damaged by excessive water when the engine is cleaned. Pressure washers and steam cleaners should not be directed at any electrical connectors or the junction of cables into the rear of the connectors. Avoid electrical components such as the alternator, the starter, and the ECM. Protect the fuel injection pump from fluids in order to wash the engine.

Aftertreatment

During the engine cleaning process, ensure that water or cleaning fluids cannot enter the aftertreatment system. If cleaning fluids enters the aftertreatment system, damage could occur.

i04932800

Engine Air Cleaner Element (Dual Element) - Inspect/Clean/Replace

SMCS Code: 1051; 1054-040; 1054-070; 1054-510

NOTICE

Never run the engine without an air cleaner element installed. Never run the engine with a damaged air cleaner element. Do not use air cleaner elements with damaged pleats, gaskets or seals. Dirt entering the engine causes premature wear and damage to engine components. Air cleaner elements help to prevent airborne debris from entering the air inlet.

NOTICE

Never service the air cleaner element with the engine running since this will allow dirt to enter the engine.

Servicing the Air Cleaner Elements

Note: The air filter system may not have been provided by Caterpillar. The procedure that follows is for a typical air filter system. Refer to the OEM information for the correct procedure.

If the air cleaner element becomes plugged, the air can split the material of the air cleaner element. Unfiltered air will drastically accelerate internal engine wear. Refer to the OEM information for the correct air cleaner elements for your application.

- Check the precleaner (if equipped) and the dust bowl daily for accumulation of dirt and debris. Remove any dirt and debris, as needed.
- Operating in dirty conditions may require more frequent service of the air cleaner element.
- The air cleaner element should be replaced at least one time per year. This replacement should be performed regardless of the number of cleanings.

Replace the dirty air cleaner elements with clean air cleaner elements. Before installation, the air cleaner elements should be thoroughly checked for tears and/or holes in the filter material. Inspect the gasket or the seal of the air cleaner element for damage. Maintain a supply of suitable air cleaner elements for replacement purposes.

Dual Element Air Cleaners

The dual element air cleaner contains a primary air cleaner element and a secondary air cleaner element.

The primary air cleaner element can be used up to six times if the element is properly cleaned and properly inspected. The primary air cleaner element should be replaced at least one time per year. This replacement should be performed regardless of the number of cleanings.

The secondary air cleaner element is not serviceable. Refer to the OEM information for instructions in order to replace the secondary air cleaner element.

When the engine is operating in environments that are dusty or dirty, air cleaner elements may require more frequent replacement.

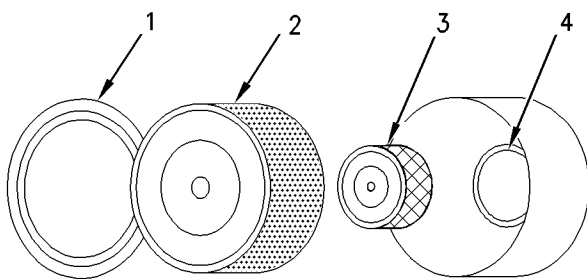

Illustration 72

g00736431

- (1) Cover
- (2) Primary air cleaner element
- (3) Secondary air cleaner element
- (4) Air inlet

1. Remove the cover. Remove the primary air cleaner element.

2. The secondary air cleaner element should be removed and discarded for every three cleanings of the primary air cleaner element.

Note: Refer to “Cleaning the Primary Air Cleaner Elements”.

3. Cover the air inlet with tape in order to keep out dirt.
4. Clean the inside of the air cleaner cover and body with a clean, dry cloth.
5. Remove the tape from the air inlet. Install the secondary air cleaner element. Install a primary air cleaner element that is new or cleaned.
6. Install the air cleaner cover.
7. Reset the air cleaner service indicator.

Cleaning the Primary Air Cleaner Elements

Refer to the OEM information in order to determine the number of times that the primary filter element can be cleaned. When the primary air cleaner element is cleaned, check for rips or tears in the filter material. The primary air cleaner element should be replaced at least one time per year. This replacement should be performed regardless of the number of cleanings.

NOTICE

Do not tap or strike the air cleaner element.

Do not wash the primary air cleaner element.

Use low pressure (207 kPa 30 psi maximum) pressurized air or vacuum cleaning to clean the primary air cleaner element.

Take extreme care in order to avoid damage to the air cleaner elements.

Do not use air cleaner elements that have damaged pleats, gaskets, or seals.

Refer to the OEM information in order to determine the number of times that the primary air cleaner element can be cleaned. Do not clean the primary air filter element more than three times. The primary air cleaner element must be replaced at least one time per year.

Cleaning the air filter element will not extend the life of the air filter element.

Visually inspect the primary air cleaner element before cleaning. Inspect air cleaner elements for damage to the pleats, the seals, the gaskets, and the outer cover. Discard any damaged air cleaner element.

Maintenance Recommendations

Engine Air Cleaner Element (Dual Element) - Inspect/Clean/Replace

Two methods may be used in order to clean the primary air cleaner element:

- pressurized air
- Vacuum cleaning

Pressurized Air**WARNING**

Personal injury can result from air pressure.

Personal injury can result without following proper procedure. When using pressure air, wear a protective face shield and protective clothing.

Maximum air pressure at the nozzle must be less than 205 kPa (30 psi) for cleaning purposes.

Pressurized air can be used to clean primary air cleaner elements that have not been cleaned more than three times. Use filtered, dry air with a maximum pressure of 207 kPa (30 psi). Pressurized air will not remove deposits of carbon and oil.

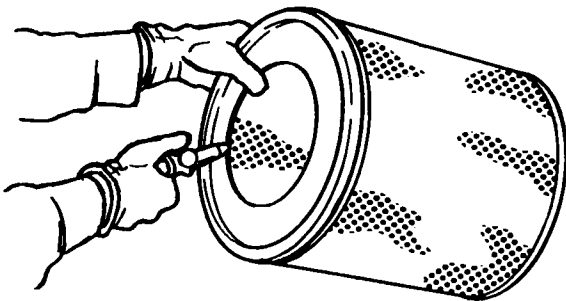

Illustration 73

g00281692

Note: When the primary air cleaner elements are cleaned, always begin with the clean side (inside) in order to force dirt particles toward the dirty side (outside).

Aim the air hose so that air flows along the length of the filter. Follow the direction of the paper pleats in order to prevent damage to the pleats. Do not aim the air directly at the face of the paper pleats.

Note: Refer to “Inspecting the Primary Air Cleaner Elements”.

Vacuum Cleaning

Vacuum cleaning is a good method for removing accumulated dirt from the dirty side (outside) of a primary air cleaner element. Vacuum cleaning is especially useful for cleaning primary air cleaner elements which require daily cleaning because of a dry, dusty environment.

Cleaning from the clean side (inside) with pressurized air is recommended prior to vacuum cleaning the dirty side (outside) of a primary air cleaner element.

Note: Refer to “Inspecting the Primary Air Cleaner Elements”.

Inspecting the Primary Air Cleaner Elements

Illustration 74

g00281693

Inspect the clean, dry primary air cleaner element. Use a 60 W blue light in a dark room or in a similar facility. Place the blue light in the primary air cleaner element. Rotate the primary air cleaner element. Inspect the primary air cleaner element for tears and/or holes. Inspect the primary air cleaner element for light that may show through the filter material. If it is necessary in order to confirm the result, compare the primary air cleaner element to a new primary air cleaner element that has the same part number.

Do not use a primary air cleaner element that has any tears and/or holes in the filter material. Do not use a primary air cleaner element with damaged pleats, gaskets, or seals. Discard damaged primary air cleaner elements.

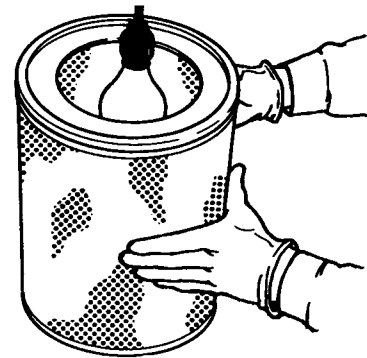
i01432811

Engine Air Cleaner Element (Single Element) - Inspect/Replace

SMCS Code: 1051; 1054-040; 1054-510

Perform the Operation and Maintenance Manual, "Engine Air Cleaner Service Indicator-Inspect" procedure and perform the Operation and Maintenance Manual, "Engine Air Precleaner Check/Clean" procedure (if equipped) before performing the following procedure.

NOTICE

Never run the engine without an air cleaner element installed. Never run the engine with a damaged air cleaner element. Do not use air cleaner elements with damaged pleats, gaskets or seals. Dirt entering the engine causes premature wear and damage to engine components. Air cleaner elements help to prevent airborne debris from entering the air inlet.

NOTICE

Never service the air cleaner element with the engine running since this will allow dirt to enter the engine.

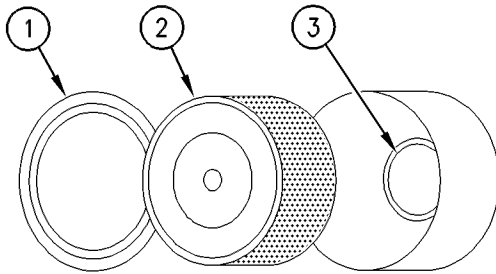

Illustration 75

g00310664

- (1) Air cleaner cover
- (2) Air filter element
- (3) Air inlet

1. Remove air cleaner cover (1) and remove air filter element (2).
2. Cover air inlet (3) with tape or a clean cloth so that debris cannot enter the air inlet.
3. Clean the inside of air cleaner cover (1). Clean the body that holds the air cleaner element.
4. Inspect the replacement element for the following items: damage, dirt and debris.

5. Remove the seal from the opening of the air inlet.
6. Install a clean, undamaged air filter element (2).
7. Install air cleaner cover (1).
8. Reset the air cleaner service indicator.

i02335405

Engine Air Cleaner Service Indicator - Inspect

SMCS Code: 7452-040

Some engines may be equipped with a different service indicator.

Some engines are equipped with a differential gauge for inlet air pressure. The differential gauge for inlet air pressure displays the difference in the pressure that is measured before the air cleaner element and the pressure that is measured after the air cleaner element. As the air cleaner element becomes dirty, the pressure differential rises. If your engine is equipped with a different type of service indicator, follow the OEM recommendations in order to service the air cleaner service indicator.

The service indicator may be mounted on the air cleaner element or in a remote location.

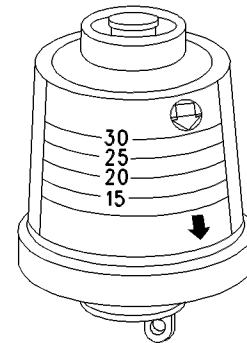

Illustration 76

g00103777

Typical service indicator

Observe the service indicator. The air cleaner element should be cleaned or the air cleaner element should be replaced when one of the following conditions occur:

- The yellow diaphragm enters the red zone.
- The red piston locks in the visible position.

Test the Service Indicator

Service indicators are important instruments.

Maintenance Recommendations

Engine Air Precleaner - Check/Clean

- Check for ease of resetting. The service indicator should reset in less than three pushes.
- Check the movement of the yellow core when the engine is accelerated to the engine rated speed. The yellow core should latch at the greatest vacuum that is attained.

If the service indicator does not reset easily, or if the yellow core does not latch at the greatest vacuum, the service indicator should be replaced. If the new service indicator will not reset, the hole for the service indicator may be restricted.

The service indicator may need to be replaced frequently in environments that are severely dusty.

i02927289

Engine Air Precleaner - Check/Clean

SMCS Code: 1055-070; 1055-535

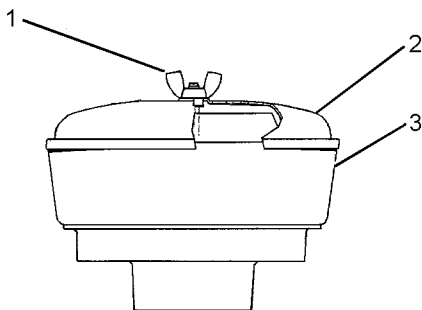

Illustration 77

g01453058

Typical engine air precleaner

- (1) Wing nut
- (2) Cover
- (3) Body

Remove wing nut (1) and cover (2). Check for an accumulation of dirt and debris in body (3). Clean the body, if necessary.

After cleaning the precleaner, install cover (2) and wing nut (1).

Note: When the engine is operated in dusty applications, more frequent cleaning is required.

i04923813

Engine Crankcase Breather Element - Replace

SMCS Code: 1317-510-FQ

WARNING

Hot oil and hot components can cause personal injury. Do not allow hot oil or hot components to contact the skin.

NOTICE

Ensure that the engine is stopped before any servicing or repair is performed.

NOTICE

Care must be taken to ensure that fluids are contained during performance of inspection, maintenance, testing, adjusting, and repair of the product. Be prepared to collect the fluid with suitable containers before opening any compartment or disassembling any component containing fluids.

Refer to Special Publication, NENG2500, "Cat Dealer Service Tool Catalog" or refer to Special Publication, PECJ0003, "Cat Shop Supplies and Tools Catalog" for tools and supplies suitable to collect and contain fluids on Cat products.

Dispose of all fluids according to local regulations and mandates.

The crankcase breather is a very important component in order to keep your engine emissions compliant.

- The filter element within the crankcase breather must be serviced at the prescribed service interval.
- The correct filter element must be installed before the engine is operated.
- The installation of the filter element is very important.
- The quality of the filter element that is installed is very important.

For information on aftermarket products, refer to Operation and Maintenance Manual, "Engine Description". Within that section, refer to the title "Aftermarket Products and Caterpillar Engines".

The breather element can be serviced from the top position or the breather element can be serviced from the bottom position.

Top Service

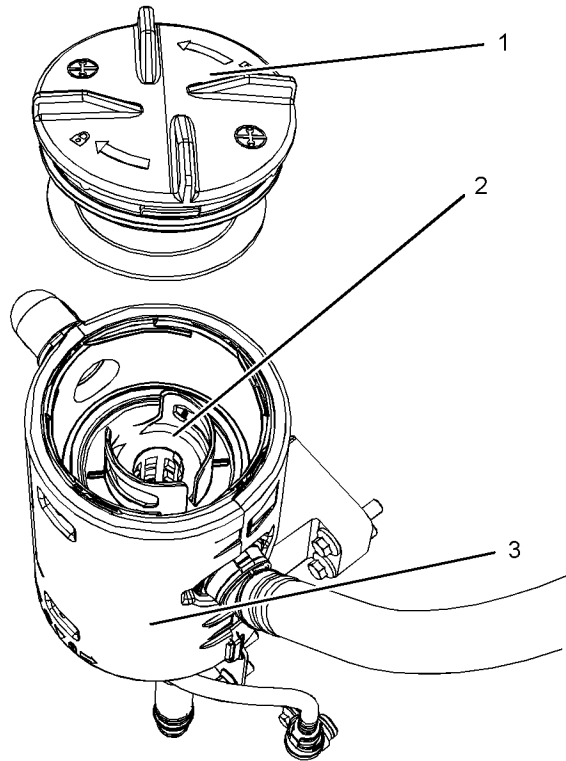

Illustration 78

g03090965

1. Ensure that dirt cannot enter the breather assembly. Ensure that the outside body of the breather assembly is clean and free from damage. Place a container under the breather assembly.
2. Rotate the top cap (1) counterclockwise into the unlocked position. Remove the top cap from the body of the breather (3) and remove the filter element (2).

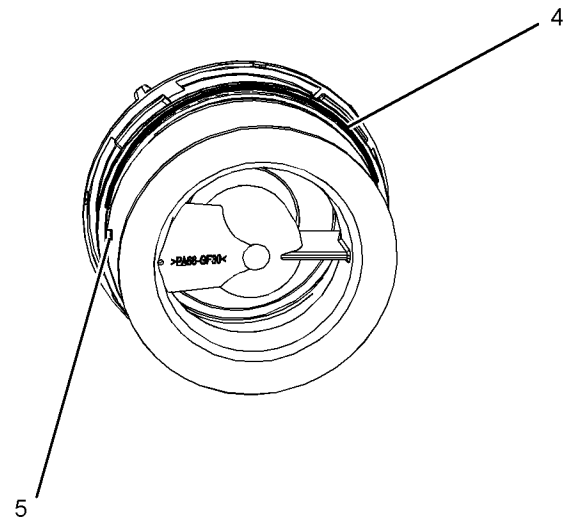

Illustration 79

g03090963

3. Remove the old seal (4) and install a new seal.

Note: The cut away from section (5) in the top cap allows access to the seal.

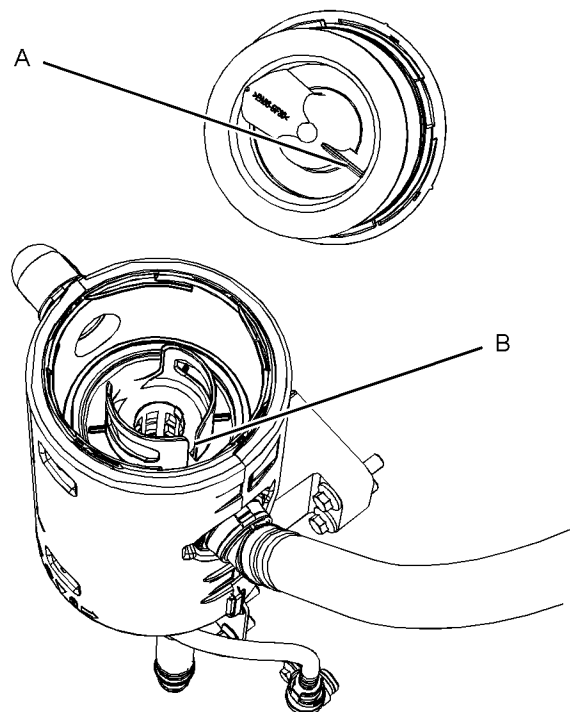

Illustration 80

g03090938

- (A) Alignment position
(B) Alignment position

Maintenance Recommendations
 Engine Crankcase Breather Element - Replace

4. Install a new filter element into the breather body (3). Ensure the correct position of the element, refer to illustration 80 . Align position (A) on the top cap to position (B) on the filter element.

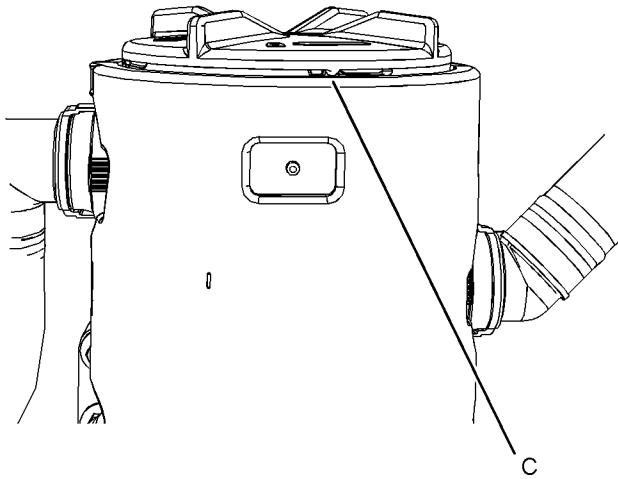

Illustration 81

g02346577

Typical example

5. Install the top cap (1). Rotate the top cap by hand clockwise until the top cap locks into the locked position (C) on the breather body.
6. Remove the container.

Bottom Service

Ensure that dirt cannot enter the breather assembly.

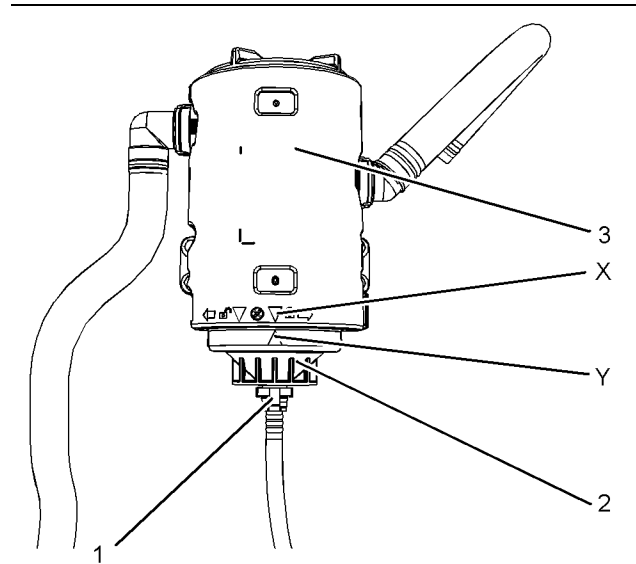

Illustration 82

g02346498

Typical example

(X) Alignment mark
 (Y) Alignment mark

1. Ensure that the outside body of the breather assembly is clean and free from damage. Place a container under the breather.
2. Remove the tube connection (1). Ensure that dirt cannot enter the tube connection. Note the position of the alignment marks (X and Y). Rotate the bottom cap (2) counterclockwise in order to release the cap and the filter element (4) from the breather body (3).

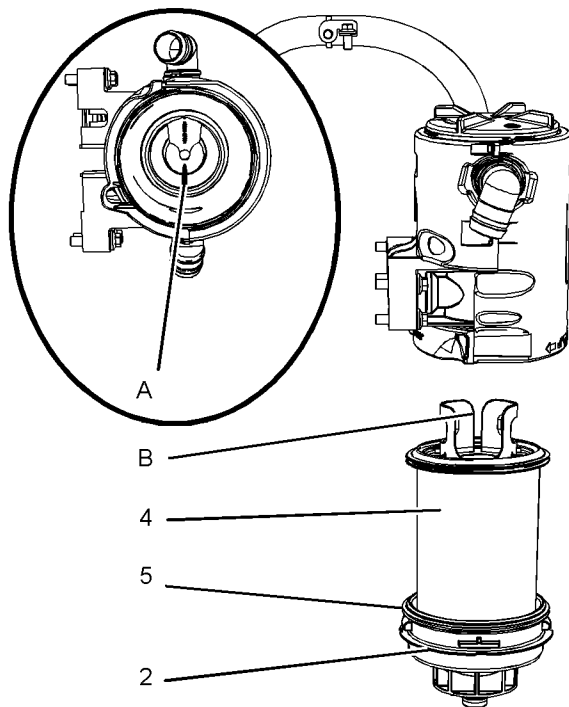

Illustration 83

g03090968

Typical example

- (A) Alignment position
(B) Alignment position

3. Remove the filter element (4). Remove the seal (5).

Note: The bottom cap has a section that allows access in order to remove the seal.

4. Install a new seal (5). Install a new filter element into the bottom cap (2).
5. Align position (A) on the top cap to position (B) on the filter element. Refer to illustration 83 .
6. Install the assembly of the filter element and the bottom cap (2). Rotate the bottom cap by hand clockwise until the bottom cap locks into the locked position on the breather body. Ensure that the alignment marks (X and Y) are correctly aligned. Refer to illustration 82 .
7. Install tube connection (1). Ensure that the retaining clips on the tube connection are correctly engaged. Remove the container.

Check the System

Illustration 84

g02346500

Typical example

Inspect the breather tube (1) for damage. Ensure that the outlet (2) is clean and free from any obstructions. Ice can cause obstructions in adverse weather conditions.

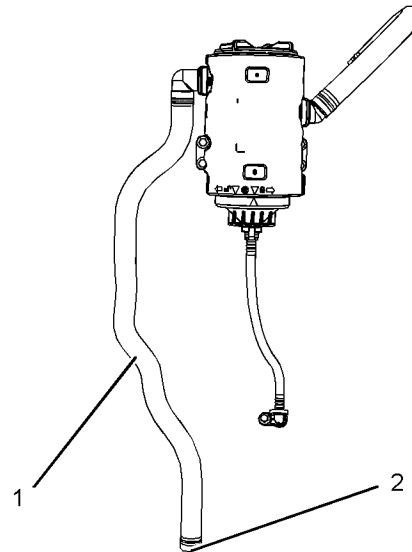
i02456872

Engine Mounts - Inspect

SMCS Code: 1152-040; 1152

Inspect the engine mounts for deterioration and for proper bolt torque. Engine vibration can be caused by the following conditions:

- Improper mounting of the engine
- Deterioration of the engine mounts

Any engine mount that shows deterioration should be replaced. Refer to Special Publication, SENR3130, Torque Specifications for the recommended torques. Refer to the OEM recommendations for more information.

i05300117

i04237495

Engine Oil Level - Check

SMCS Code: 1348-535-FLV

WARNING

Hot oil and hot components can cause personal injury. Do not allow hot oil or hot components to contact the skin.

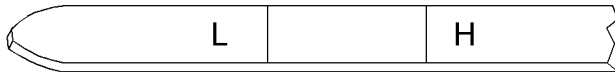

Illustration 85

g02173847

“L” Low
 “H” High

NOTICE

Perform this maintenance with the engine stopped.

Note: Ensure that the engine is either level or that the engine is in the normal operating position in order to obtain a true level indication.

Note: After the engine has been switched OFF, wait for 10 minutes in order to allow the engine oil to drain to the oil pan before checking the oil level.

1. Maintain the oil level between the mark (L) and the mark (H) on the engine oil dipstick. Do not fill the crankcase above the “H” .

NOTICE

Operating your engine when the oil level is above the “H” mark could cause your crankshaft to dip into the oil. The air bubbles created from the crankshaft dipping into the oil reduces the oils lubricating characteristics and could result in the loss of power.

2. Remove the oil filler cap and add oil, if necessary. Clean the oil filler cap. Install the oil filler cap.

If an increase in the oil level is noticed, refer to Troubleshooting, “Oil Contains Fuel”.

Engine Oil Sample - Obtain

SMCS Code: 1348-554-SM

In addition to a good preventive maintenance program, Caterpillar recommends using S·O·S oil analysis at regularly scheduled intervals. S·O·S oil analysis provides infrared analysis, which is required for determining nitration and oxidation levels.

Obtain the Sample and the Analysis

WARNING

Hot oil and hot components can cause personal injury. Do not allow hot oil or hot components to contact the skin.

Before you take the oil sample, complete the Label, PEEP5031 for identification of the sample. In order to help obtain the most accurate analysis, provide the following information:

- Engine model
- Service hours on the engine
- The number of hours that have accumulated since the last oil change
- The amount of oil that has been added since the last oil change

To ensure that the sample is representative of the oil in the crankcase, obtain a warm, mixed oil sample.

To avoid contamination of the oil samples, the tools and the supplies that are used for obtaining oil samples must be clean.

Caterpillar recommends using the sampling valve in order to obtain oil samples. The quality and the consistency of the samples are better when the sampling valve is used. The location of the sampling valve allows oil that is flowing under pressure to be obtained during normal engine operation.

The 169-8373 Fluid Sampling Bottle is recommended for use with the sampling valve. The fluid sampling bottle includes the parts that are needed for obtaining oil samples. Instructions are also provided.

NOTICE

Always use a designated pump for oil sampling, and use a separate designated pump for coolant sampling. Using the same pump for both types of samples may contaminate the samples that are being drawn. This contaminate may cause a false analysis and an incorrect interpretation that could lead to concerns by both dealers and customers.

If the engine is not equipped with a sampling valve, use the 1U-5718 Vacuum Pump. The pump is designed to accept sampling bottles. Disposable tubing must be attached to the pump for insertion into the sump.

For instructions, see Special Publication, PEGJ0047, "How To Take A Good S·O·S Oil Sample". Consult your Cat dealer for complete information and assistance in establishing an S·O·S program for your engine.

i03996035

Engine Oil and Filter - Change

SMCS Code: 1318-510

WARNING

Hot oil and hot components can cause personal injury. Do not allow hot oil or hot components to contact the skin.

NOTICE

Care must be taken to ensure that fluids are contained during performance of inspection, maintenance, testing, adjusting and repair of the product. Be prepared to collect the fluid with suitable containers before opening any compartment or disassembling any component containing fluids.

Dispose of all fluids according to local regulations and mandates.

NOTICE

Keep all parts clean from contaminants.

Contaminants may cause rapid wear and shortened component life.

Do not drain the engine lubricating oil when the engine is cold. As the engine lubricating oil cools, suspended waste particles settle on the bottom of the oil pan. The waste particles are not removed with draining cold oil. Drain the oil pan with the engine stopped. Drain the oil pan with the oil warm. This draining method allows the waste particles that are suspended in the oil to be drained properly.

Failure to follow this recommended procedure will cause the waste particles to be recirculated through the engine lubrication system with the new oil.

Drain the Engine Lubricating Oil

Note: Ensure that the vessel that will be used is large enough to collect the waste oil.

After the engine has been run at the normal operating temperature, stop the engine. Use one of the following methods to drain the engine oil pan:

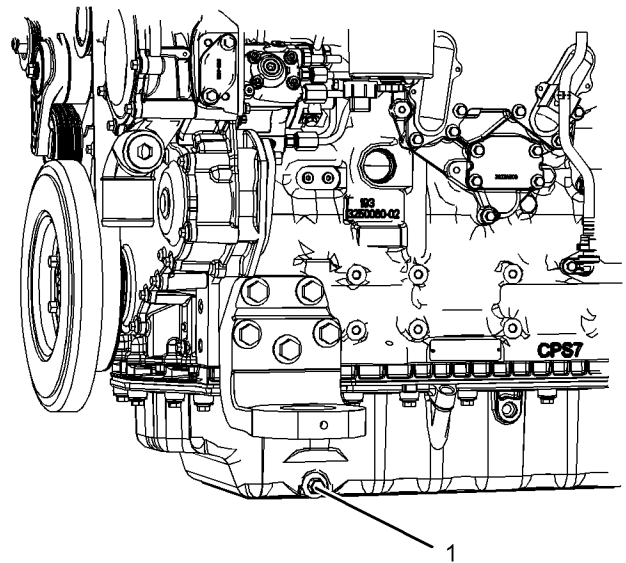

Illustration 86

g01880893

Typical example

- If the engine is equipped with a drain valve, turn the drain valve knob counterclockwise in order to drain the oil. After the oil has drained, turn the drain valve knob clockwise in order to close the drain valve.
- If the engine is not equipped with a drain valve, remove oil drain plug (1) in order to allow the oil to drain. If the engine is equipped with a shallow oil pan, remove the bottom oil drain plugs from both ends of the oil pan.

After the oil has drained, the oil drain plugs should be cleaned and installed. If necessary, replace the O ring seal. Tighten the drain plug to 34 N·m (25 lb ft).

Replace the Oil Filter

NOTICE

Caterpillar oil filters are manufactured to Caterpillar specifications. Use of an oil filter that is not recommended by Caterpillar could result in severe damage to the engine bearings, crankshaft, etc., as a result of the larger waste particles from unfiltered oil entering the engine lubricating system. Only use oil filters recommended by Caterpillar.

1. Remove the oil filter with a 1U-8760 Chain Wrench.

Note: The following actions can be carried out as part of the preventive maintenance program.

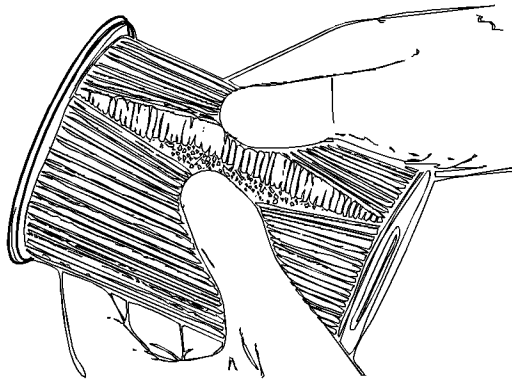

Illustration 87

g01999595

Element with debris

2. Cut the oil filter open with a 175-7546 Oil Filter Cutter. Break apart the pleats and inspect the oil filter for metal debris. An excessive amount of metal debris in the oil filter may indicate early wear or a pending failure.

Use a magnet to differentiate between the ferrous metals and the nonferrous metals that are found in the oil filter element. Ferrous metals may indicate wear on the steel and cast iron parts of the engine.

Nonferrous metals may indicate wear on the aluminum parts, brass parts or bronze parts of the engine. Parts that may be affected include the following items: main bearings, rod bearings, turbocharger bearings and cylinder heads.

Due to normal wear and friction, it is not uncommon to find small amounts of debris in the oil filter. Consult your Caterpillar dealer in order to arrange for a further analysis if an excessive amount of debris is found in the oil filter.

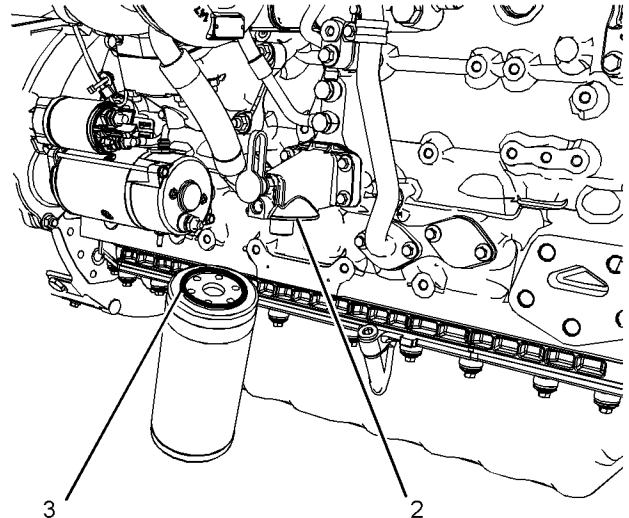

Illustration 88

g02351361

Typical example

3. Clean the sealing surface of the oil filter base (2).
4. Apply clean engine oil to the O ring seal (3) for the new oil filter.

NOTICE

Do not fill the oil filters with oil before installing them. This oil would not be filtered and could be contaminated. Contaminated oil can cause accelerated wear to engine components.

5. Install the engine oil filter. Spin on the oil filter until the O ring seal contacts the oil filter base. Rotate the oil filter $\frac{3}{4}$ of a full turn.

Fill the Oil Pan

1. Remove the oil filler cap. Refer to this Operation and Maintenance Manual, "Fluid Recommendations" for more information on suitable oils. Fill the oil pan with the correct amount of new engine lubricating oil. Refer to this Operation and Maintenance Manual, "Refill Capacities" for more information on refill capacities.

NOTICE

If equipped with an auxiliary oil filter system or a remote filter system, follow the OEM or the filter manufacturer's recommendations. Under filling or over filling the crankcase with oil can cause engine damage.

2. Start the engine and run the engine at "LOW IDLE" for 2 minutes. Perform this procedure in order to ensure that the lubrication system has oil and that the oil filters are filled. Inspect the oil filter for oil leaks.
 3. Stop the engine and allow the oil to drain back to the oil pan for a minimum of 10 minutes.
-

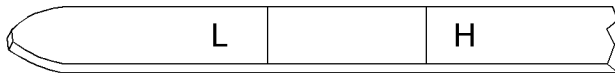

Illustration 89

g02173847

"L" Low

"H" High

4. Remove the engine oil level gauge in order to check the oil level. Maintain the oil level between the "L" and "H" marks on the engine oil level gauge. Do not fill the crankcase above the "H" mark.

i05404932

Fan Clearance - Check

SMCS Code: 1356; 1359; 1360

There are different types of cooling systems that can be installed. Refer to the Original Equipment Manufactory (OEM) for your application for more information.

Ensure that the engine is stopped and allow 2 minutes before the battery disconnect switch is turned off. This procedure will allow the Diesel Exhaust Fluid (DEF) system to purged.

Ensure that the cooling system is full before checking the fan tip clearance. The fan tip clearance is the distance between the tip of the fan blade (2) and the edge of the cover (1).

Maintenance Recommendations
 Fuel Filter (In-Line) - Replace

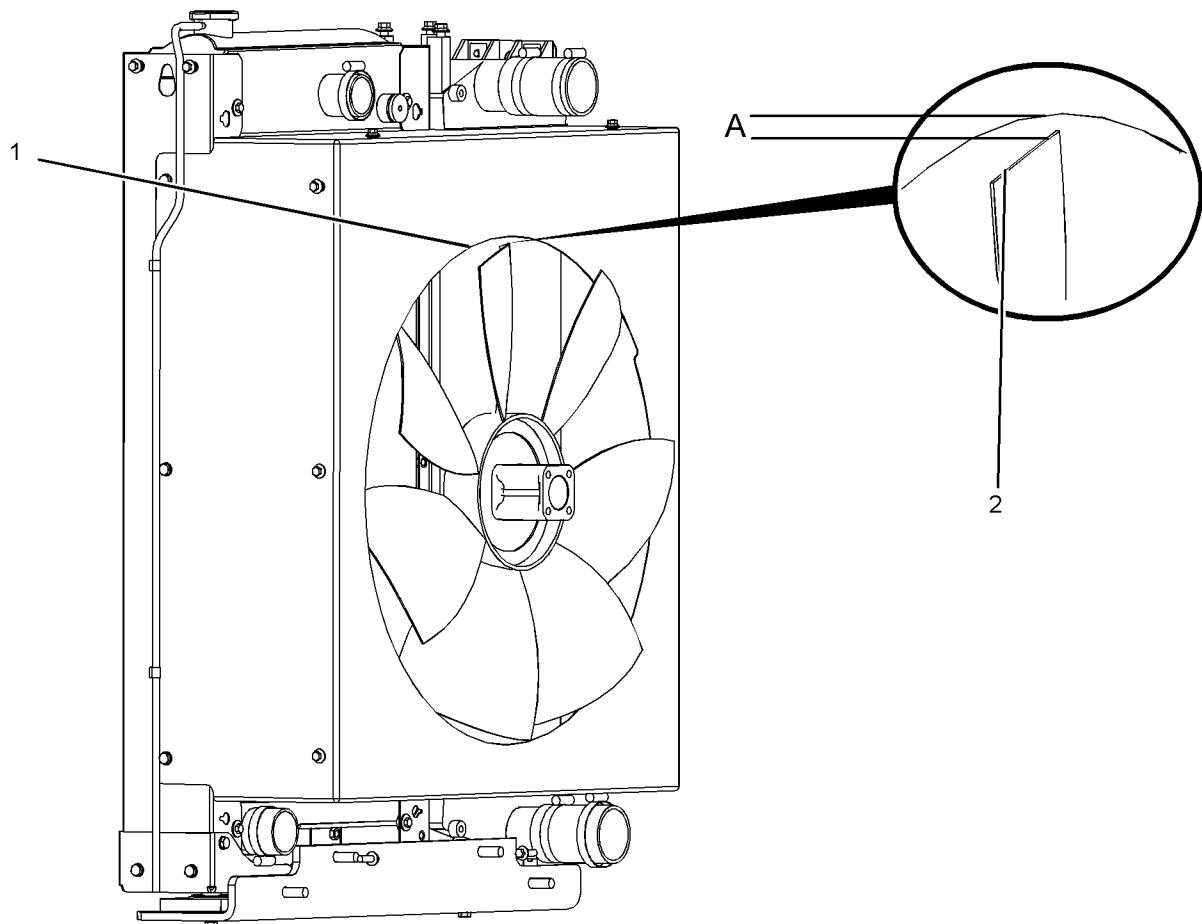

Illustration 90

g03414037

Typical example

The gap (A) must be checked in the vertical position and in the horizontal position.

In the vertical position the gap can be checked at the vertically top position or at the vertically bottom position.

- Gap (A) vertical top position 12 ± 1 mm (0.47244 ± 0.03937 inch).
- Gap (A) vertical bottom position 8 ± 1 mm (0.31496 ± 0.03937 inch).

After the gap (A) has been checked in the vertical top position or the vertical bottom position, the horizontal position must be checked.

- Gap (A) in the horizontal position must be a minimum of 9 mm (0.35433 inch).

If the fan tip clearance requires adjustment, refer to the Disassembly and Assembly manual for more information.

i04921339

Fuel Filter (In-Line) - Replace

SMCS Code: 1261-510; 1261

WARNING

Fuel leaked or spilled onto hot surfaces or electrical components can cause a fire. To help prevent possible injury, turn the start switch off when changing fuel filters or water separator elements. Clean up fuel spills immediately.

Note: Refer to Systems Operation, Testing, and Adjusting, “Cleanliness of Fuel System Components” for detailed information on the standards of cleanliness that must be observed during ALL work on the fuel system.

NOTICE

Ensure that the engine is stopped before any servicing or repair is performed.

i03906114

The location of the in-line fuel filter will depend on the application that the engine has been installed.

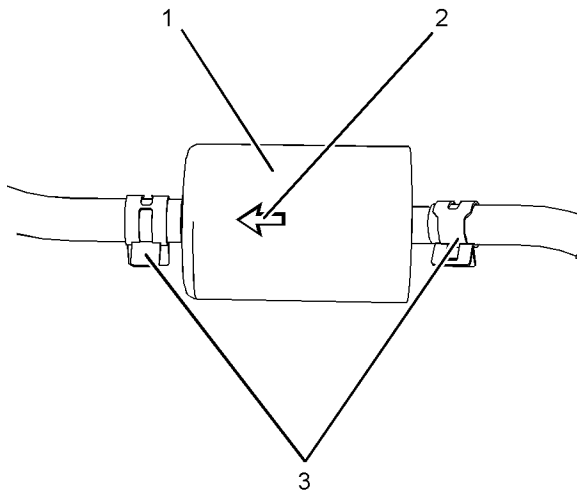

Illustration 91

g03086919

Typical example

1. Turn the fuel supply valve (if equipped) to the OFF position. Remove any brackets that hold the in-line fuel filter (1) in place, refer to OEM information.
2. Release the hose clips (3) and remove the hose lines from the in-line fuel filter. Remove the in-line filter.
3. Install a new in-line filter and secure, refer to OEM information. Ensure that the arrow mark (2) is aligned to the direction of fuel flow from the tank to the fuel pump.
4. Install the fuel hose lines and install the hose clips (3). Turn the fuel supply valve (if equipped) to the ON position.
5. The in-line fuel filter must be changed with the primary filter and the secondary fuel filter.

Fuel System - Prime

SMCS Code: 1250-548; 1258-548

Note: Refer to **Systems Operation, Testing, and Adjusting, “Cleanliness of Fuel System Components”** for detailed information on the standards of cleanliness that must be observed during ALL work on the fuel system.

Ensure that all adjustments and repairs are performed by authorized personnel that have had the correct training.

NOTICE

Do not crank the engine continuously for more than 30 seconds. Allow the starting motor to cool for two minutes before cranking the engine again.

If air enters the fuel system, the air must be purged from the fuel system before the engine can be started. Air can enter the fuel system when the following events occur:

- The fuel tank is empty or the fuel tank has been partially drained.
- The low-pressure fuel lines are disconnected.
- A leak exists in the low-pressure fuel system.
- The fuel filter has been replaced.

Use the following procedures in order to remove air from the fuel system:

1. Ensure that the fuel system is in working order. Check that the fuel supply valve (if equipped) is in the “ON” position.
2. Turn the keyswitch to the “RUN” position.
3. The keyswitch will allow the electric priming pump to operate. Operate the electric priming pump. The ECM will stop the pump after 2 minutes.
4. Turn the keyswitch to the “OFF” position. The fuel system should now be primed and the engine should be able to start.
5. Operate the engine starter and crank the engine. After the engine has started, operate the engine at low idle for a minimum of 5 minutes. Ensure that the fuel system is free from leaks.

Note: Operating the engine for this period will help ensure that the fuel system is free of air. **DO NOT loosen the high-pressure fuel lines in order to purge air from the fuel system. This procedure is not required.**

Maintenance Recommendations

Fuel System Primary Filter (Water Separator) Element - Replace

After the engine has stopped, you must wait for 10 minutes in order to allow the fuel pressure to be purged from the high-pressure fuel lines before any service or repair is performed on the engine fuel lines. If necessary, perform minor adjustments. Repair any leaks from the low-pressure fuel system and from the cooling, lubrication, or air systems. Replace any high-pressure fuel line that has leaked. Refer to Disassembly and Assembly Manual, "Fuel Injection Lines - Install".

If you inspect the engine in operation, always use the proper inspection procedure in order to avoid a fluid penetration hazard. Refer to Operation and Maintenance Manual, "General hazard Information".

If the engine will not start, refer to Troubleshooting, "Engine Cranks but will not Start".

i04921313

Fuel System Primary Filter (Water Separator) Element - Replace

SMCS Code: 1260-510-FQ; 1263-510-FQ

WARNING

Fuel leaked or spilled onto hot surfaces or electrical components can cause a fire. To help prevent possible injury, turn the start switch off when changing fuel filters or water separator elements. Clean up fuel spills immediately.

Note: Refer to Systems Operation, Testing, and Adjusting, "Cleanliness of Fuel System Components" for detailed information on the standards of cleanliness that must be observed during ALL work on the fuel system.

NOTICE

Ensure that the engine is stopped before any servicing or repair is performed.

Remove the Element

1. Turn the fuel supply valve (if equipped) to the OFF position before performing this maintenance.
2. Place a suitable container under the water separator in order to catch any fuel that might spill. Clean up any spilled fuel. Clean the outside body of the filter assembly.

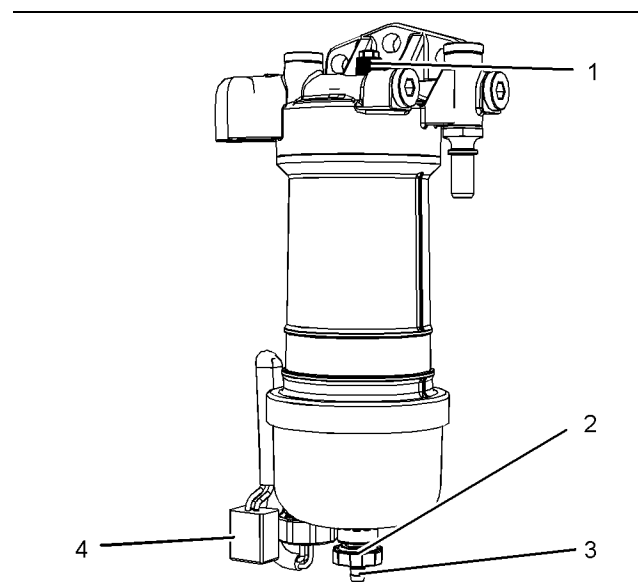

Illustration 92

g03086757

Typical example

3. Install a suitable tube onto drain (3). Open the drain valve (2). Rotate the drain valve counterclockwise. Two full turns are required.
4. Loosen the vent screw (1).
5. Allow the fuel to drain into the container. Remove the tube from the drain valve.
6. Tighten the vent screw (1) securely. Remove the wiring harness from connection (4).
7. Rotate filter bowl (6) counterclockwise and remove the filter bowl from assembly. Refer to your caterpillar dealer for the correct tool.

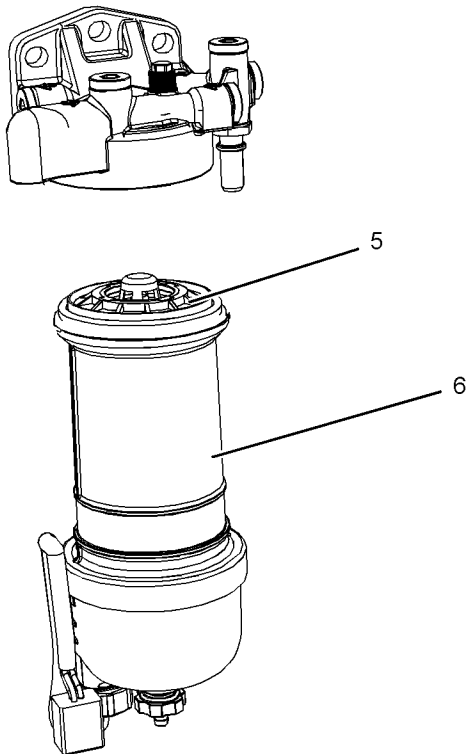

Illustration 93

g02148402

Typical example

8. Rotate the filter element (5) counterclockwise and remove the filter element . Clean the filter bowl.

Install the New Filter Element

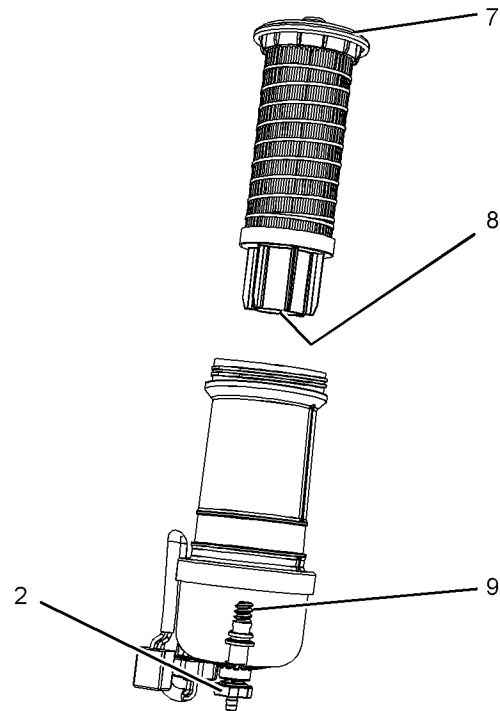

Illustration 94

g03086798

Typical example

1. Locate the thread in the new filter element (8) onto the threads (9). Spin on the filter element and tighten the drain valve (2) securely.
2. Lubricate the O ring seal (7) with clean engine oil. Do NOT fill the bowl with fuel before the assembly is installed.
3. Do not use a tool in order to install the filter assembly. Tighten the filter bowl (6) by hand. Install the filter bowl (6). Turn the filter bowl clockwise until the filter bowl locks into position against the stops.
4. Remove the container and dispose of the fuel in a safe place.
5. The secondary filter element must be replaced at the same time as the primary filter element. Also, the in-line filter must be changed. Refer to the Operation and Maintenance Manual, "Fuel System Filter - Replace".

i04925799

Fuel System Primary Filter/ Water Separator - Drain

SMCS Code: 1260-543; 1263-543

⚠ WARNING

Fuel leaked or spilled onto hot surfaces or electrical components can cause a fire. To help prevent possible injury, turn the start switch off when changing fuel filters or water separator elements. Clean up fuel spills immediately.

NOTICE

Ensure that the engine is stopped before any servicing or repair is performed.

NOTICE

The water separator can be under suction during normal engine operation. Ensure that the drain valve is tightened securely to help prevent air from entering the fuel system.

1. Place a suitable container under the water separator in order to catch any fluid that might spill. Clean up any spilled fluid.
2. Ensure that the outer body of the filter assembly is clean and free from dirt.

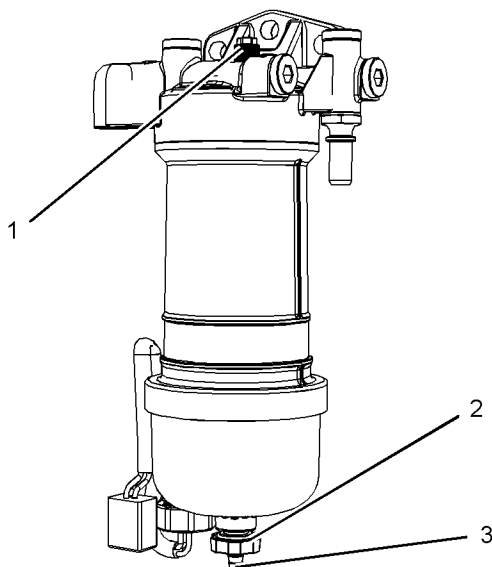

Illustration 95

g02148370

Typical example

3. Install a suitable tube onto drain (3). Open the drain valve (2). Rotate the drain valve counterclockwise. Two full turns are required. Loosen vent screw (1).
4. Allow the fluid to drain into the container.
5. Tighten the drain valve clockwise by hand pressure only. Remove the tube and remove the container.
6. Tighten the vent screw securely.

i04921888

Fuel System Secondary Filter - Replace

SMCS Code: 1261-510-SE

⚠ WARNING

Fuel leaked or spilled onto hot surfaces or electrical components can cause a fire. To help prevent possible injury, turn the start switch off when changing fuel filters or water separator elements. Clean up fuel spills immediately.

NOTICE

Ensure that the engine is stopped before any servicing or repair is performed.

Refer to Systems Operation, Testing, and Adjusting, "Cleanliness of Fuel System Components" for detailed information on the standards of cleanliness that must be observed during ALL work on the fuel system.

Remove the Element

1. Turn the fuel supply valve (if equipped) to the OFF position before performing this maintenance.
2. Place a suitable container under the fuel filter in order to catch any fuel that might spill. Clean up any spilled fuel. Clean the outside body of the filter assembly.

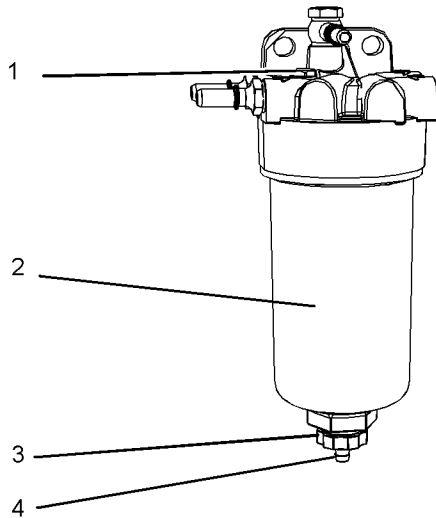

Illustration 96

g03088718

3. Install a suitable tube onto drain (4). Open the drain valve (3). Rotate the drain valve counterclockwise. Two full turns are required. Loosen vent screw (1).
4. Allow the fuel to drain into the container and remove the tube.
5. Tighten the vent screw (1) securely.
6. Remove the filter bowl (2). Rotate the filter assembly counterclockwise in order to remove the assembly. Refer to your caterpillar dealer for the correct tool number.

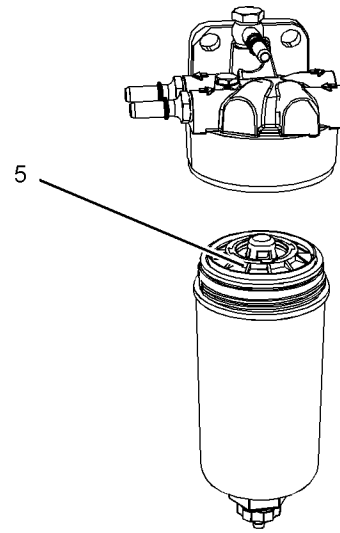

Illustration 97

g02546456

7. Rotate the filter element (5) counterclockwise and remove the filter element. Clean the filter bowl.

Install the Element

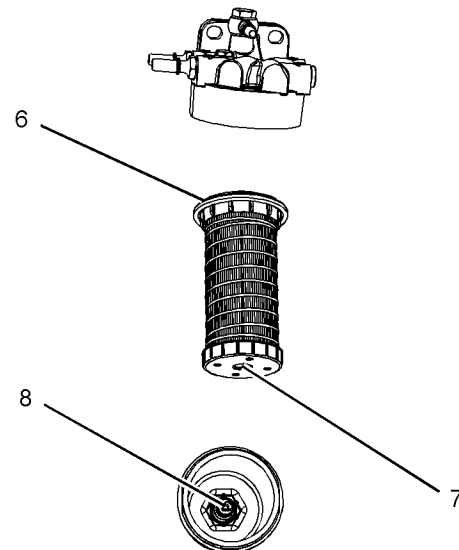

Illustration 98

g03088837

1. Locate the thread (7) in the filter element onto the threads (8). Spin on the element and tighten the drain valve (3) by hand.
2. Lubricate the O ring seal (6) with clean engine oil. Do NOT fill the filter bowl (2) with fuel before the filter assembly is installed.

3. Do not use a tool in order to install the filter assembly. Tighten the assembly by hand. Install the filter bowl (2). Turn the filter bowl clockwise until the filter bowl locks into position against the stops.
4. Turn the fuel supply valve to the ON position.
5. The primary fuel filter the secondary fuel filter must be replaced at the same time. Refer to the Operation and Maintenance Manual, "Fuel System Primary Filter (Water Separator) Element - Replace". Also, the in-line fuel must be replaced when the primary and secondary filters are replaced. Refer to Operation and Maintenance Manual, "Fuel Filter (In-Line)- Replace"
6. Prime the fuel system. Refer to the Operation and Maintenance Manual, "Fuel System - Prime" for more information.

i02348492

Fuel Tank Water and Sediment - Drain

SMCS Code: 1273-543-M&S

NOTICE

Care must be taken to ensure that fluids are contained during performance of inspection, maintenance, testing, adjusting and repair of the product. Be prepared to collect the fluid with suitable containers before opening any compartment or disassembling any component containing fluids.

Dispose of all fluids according to local regulations and mandates.

Fuel Tank

Fuel quality is critical to the performance and to the service life of the engine. Water in the fuel can cause excessive wear to the fuel system.

Water can be introduced into the fuel tank when the fuel tank is being filled.

Condensation occurs during the heating and cooling of fuel. The condensation occurs as the fuel passes through the fuel system and the fuel returns to the fuel tank. This causes water to accumulate in fuel tanks. Draining the fuel tank regularly and obtaining fuel from reliable sources can help to eliminate water in the fuel.

Drain the Water and the Sediment

Fuel tanks should contain some provision for draining water and draining sediment from the bottom of the fuel tanks.

Open the drain valve on the bottom of the fuel tank in order to drain the water and the sediment. Close the drain valve.

Check the fuel daily. Allow five minutes after the fuel tank has been filled before draining water and sediment from the fuel tank.

Fill the fuel tank after operating the engine in order to drive out moist air. This will help prevent condensation. Do not fill the tank to the top. The fuel expands as the fuel gets warm. The tank may overflow.

Some fuel tanks use supply pipes that allow water and sediment to settle below the end of the fuel supply pipe. Some fuel tanks use supply lines that take fuel directly from the bottom of the tank. If the engine is equipped with this system, regular maintenance of the fuel system filter is important.

Fuel Storage Tanks

Drain the water and the sediment from the fuel storage tank at the following intervals:

- Weekly
- Service intervals
- Refill of the tank

This will help prevent water or sediment from being pumped from the storage tank into the engine fuel tank.

If a bulk storage tank has been refilled or moved recently, allow adequate time for the sediment to settle before filling the engine fuel tank. Internal baffles in the bulk storage tank will also help trap sediment. Filtering fuel that is pumped from the storage tank helps to ensure the quality of the fuel. When possible, water separators should be used.

i02518232

Hoses and Clamps - Inspect/ Replace

SMCS Code: 7554-040; 7554-510

WARNING

Contact with high pressure fuel may cause fluid penetration and burn hazards. High pressure fuel spray may cause a fire hazard. Failure to follow these inspection, maintenance and service instructions may cause personal injury or death.

If you inspect the engine in operation, always use the proper inspection procedure in order to avoid a fluid penetration hazard. Refer to Operation and Maintenance Manual, "General hazard Information".

Inspect all hoses for leaks that are caused by the following conditions:

- Cracking
- Softness
- Loose clamps

Replace hoses that are cracked or soft. Tighten any loose clamps.

Check for the following conditions:

- End fittings that are damaged or leaking
- Outer covering that is chafed or cut
- Exposed wire that is used for reinforcement
- Outer covering that is ballooning locally
- Flexible part of the hose that is kinked or crushed
- Armoring that is embedded in the outer covering

A constant torque hose clamp can be used in place of any standard hose clamp. Ensure that the constant torque hose clamp is the same size as the standard clamp.

Due to extreme temperature changes, the hose will harden. Hardening of the hoses will cause hose clamps to loosen. This can result in leaks. A constant torque hose clamp will help to prevent loose hose clamps.

Each installation application can be different. The differences depend on the following factors:

- Type of hose
- Type of fitting material
- Anticipated expansion and contraction of the hose
- Anticipated expansion and contraction of the fittings

Replace the Hoses and the Clamps

Refer to the OEM information for further information on removing and replacing fuel hoses (if equipped).

The following text describes a typical method of replacing coolant hoses. Refer to the OEM information for further information on the coolant system and the hoses for the coolant system.

WARNING

Pressurized System: Hot coolant can cause serious burns. To open the cooling system filler cap, stop the engine and wait until the cooling system components are cool. Loosen the cooling system pressure cap slowly in order to relieve the pressure.

1. Stop the engine. Allow the engine to cool.
2. Loosen the cooling system filler cap slowly in order to relieve any pressure. Remove the cooling system filler cap.

Note: Drain the coolant into a suitable, clean container. The coolant can be reused.

3. Drain the coolant from the cooling system to a level that is below the hose that is being replaced.
4. Remove the hose clamps.
5. Disconnect the old hose.
6. Replace the old hose with a new hose.
7. Install the hose clamps with a torque wrench.

Note: For the correct coolant, see this Operation and Maintenance Manual, "Fluid Recommendations".

8. Refill the cooling system. Refer to the OEM information for further information on refilling the cooling system.
9. Clean the cooling system filler cap. Inspect the cooling system filler cap's seals. Replace the cooling system filler cap if the seals are damaged. Install the cooling system filler cap.
10. Start the engine. Inspect the cooling system for leaks.

i05414590

Injector (Diesel Exhaust Fluid) - Replace

SMCS Code: 108I-510

Maintenance Recommendations

Injector (Diesel Exhaust Fluid) - Replace

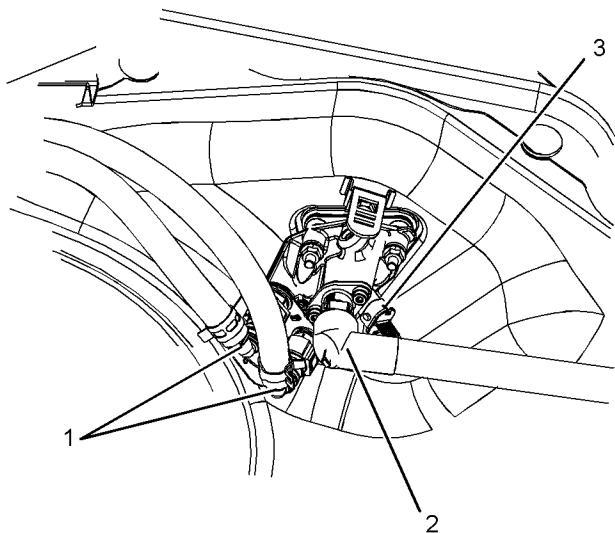

Illustration 99

g03418548

Typical example

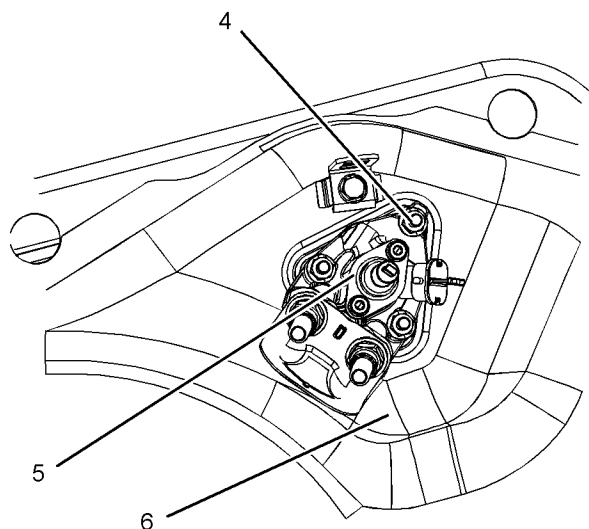

Illustration 100

g03418553

Typical example

1. Drain the coolant in order to remove the coolant lines (1). Remove the cooling lines (1) and remove Diesel Exhaust Fluid (DEF) line (2).
2. Remove electrical connect from position (3) and install protection caps to DEF injector (5). Remove nuts (4) and washers (9) from DEF injector (5) and remove DEF injector from Clean Emission Module (CEM) (6).

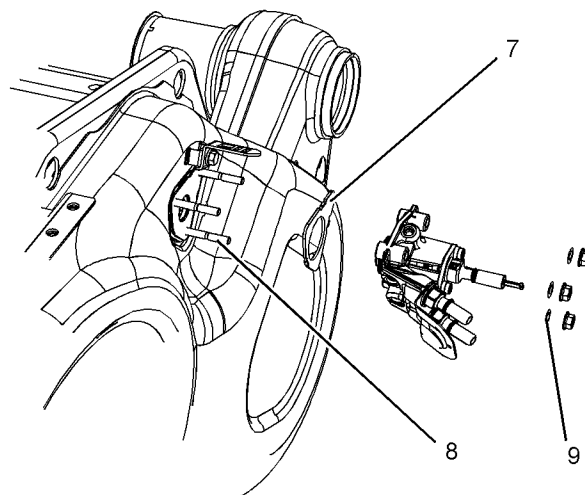

Illustration 101

g03418578

Typical example

3. Remove gasket (7) and remove the studs (8). Discard the gasket and the studs.
4. Ensure that the sealing face of the CEM is clean and free from dirt.
5. Apply bostik pure nickel ant-seize compound to ends of the new studs (8). Install the coated ends of the new studs into the CEM, and tighten to a torque of 5 N·m (44 lb in).
6. Install new gasket (7), ensure that the metal side of the gasket is to the CEM. Install new DEF injector (5) to CEM (6).
7. Install washers (9) and apply bostik pure nickel ant-seize compound to the threads of the studs (8).
8. Install the nuts (4) and tighten the nuts to a torque of 5 N·m (44 lb in). Retighten the nuts to 5 N·m (44 lb in). Then, turn the nuts additional 90 degrees.
9. Install electrical connection into position (3) and install DEF line (2). Install coolant lines (1).
10. Fill cooling system to the correct level. Ensure that the correct specification of coolant is used.

If available, using the electronic service tool (ET) perform DEF Dosing System Verification test.

i04224312

Overhaul Considerations

SMCS Code: 7595-043

Reduced hours of operation at full load will result in a lower average power demand. A decreased average power demand should increase both the engine service life and the overhaul interval.

The need for an overhaul is indicated by increased fuel consumption, increased oil consumption, excessive engine blowby, and reduced power. Arctic temperatures, extreme high temperatures, corrosive environments, or extreme dusty conditions contribute to premature wear and the need for an overhaul.

The following factors are important when a decision is being made on the proper time for an engine overhaul:

- The need for preventive maintenance
- The quality of the fuel that is being used
- The operating conditions
- The results of the S·O·S analysis

Oil Consumption as an Overhaul Indicator

Oil consumption, fuel consumption, and maintenance information can be used to estimate the total operating cost for your Caterpillar engine. Oil consumption can also be used to estimate the required capacity of a makeup oil tank that is suitable for the maintenance intervals.

Oil consumption is in proportion to the percentage of the rated engine load. As the percentage of the engine load is increased, the amount of oil that is consumed per hour also increases.

The oil consumption rate (brake-specific oil consumption) is measured in grams per kW/h (lb per bhp). The brake-specific oil consumption (BSOC) depends on the engine load. Consult your Caterpillar dealer for assistance in determining the typical oil consumption rate for your engine.

When an engine's oil consumption has risen to three times the original oil consumption rate due to normal wear, an engine overhaul should be scheduled. There may be a corresponding increase in blowby and a slight increase in fuel consumption.

Overhaul Options

Before Failure Overhaul

A planned overhaul before failure may be the best value for the following reasons:

- Costly unplanned downtime can be avoided.
- Many original parts can be reused according to the standards for reusable parts.
- The engine's service life can be extended without the risk of a major catastrophe due to engine failure.
- The best cost/value relationship per hour of extended life can be attained.

After Failure Overhaul

If a major engine failure occurs and the engine must be removed, many options are available. An overhaul should be performed if the engine block or the crankshaft needs to be repaired.

If the engine block is repairable and/or the crankshaft is repairable, the overhaul cost will be less than the cost of a new engine with a similar exchange core.

This lower cost can be attributed to three aspects:

- Specially designed Caterpillar engine features
- Caterpillar dealer exchange components
- Caterpillar Inc. remanufactured exchange components

Overhaul Recommendation

To minimize downtime, Caterpillar Inc. recommends a scheduled engine overhaul by your Caterpillar dealer before the engine fails. This process will provide you with the best cost/value relationship.

Note: Overhaul programs vary according to the engine application and according to the dealer that performs the overhaul. Consult your Caterpillar dealer for specific information about the available overhaul programs and about overhaul services for extending the engine life.

Aftertreatment

The aftertreatment system can be expected to function properly for the useful life of the engine (emissions durability period), as defined by regulation, subject to prescribed maintenance requirements being followed.

Rebuild or Exchange

If an overhaul is performed without overhaul service from your Caterpillar dealer, be aware of the following maintenance recommendations.

Cylinder Head Assembly, Oil Pump, and Fuel Transfer Pump

These components should be inspected according to the instructions that are found in various Caterpillar reusability publications. The Special Publication, SEBF8029 lists the reusability publications that are needed for inspecting the engine parts.

If the parts comply with the established inspection specifications that are expressed in the reusable parts guideline, the parts should be reused.

Parts that are not within the established inspection specifications should be dealt with in one of the following manners:

- Salvaging
- Repairing
- Replacing

Using out-of-spec parts can result in the following problems:

- Unscheduled downtime
- Costly repairs
- Damage to other engine parts
- Reduced engine efficiency
- Increased fuel consumption

Reduced engine efficiency and increased fuel consumption translates into higher operating costs. Therefore, Caterpillar Inc. recommends repairing out-of-spec parts or replacing out-of-spec parts.

Inspection and/or Replacement

Crankshaft Bearings Crankshaft Seals and Pistons

The following components may not last until the second overhaul.

- Thrust bearings
- Main bearings
- Rod bearings
- Crankshaft seals
- Piston assembly

Caterpillar Inc. recommends the installation of new parts at each overhaul period.

Inspect these parts while the engine is disassembled for an overhaul.

Inspect the crankshaft for any of the following conditions:

- Deflection
- Damage to the journals
- Bearing material that has seized to the journals

Check the journal taper and the profile of the crankshaft journals. If the wear patterns on the rod bearing or the main bearing show a problem, the crankshaft will need to be measured with specialist equipment.

Inspect the camshaft for damage to the journals and to the lobes.

Note: If the camshaft is removed for any reason, use the magnetic particle inspection process to check for cracks in the camshaft.

Inspect the following components for signs of wear or for signs of scuffing:

- Camshaft bearings
- Lifters

Caterpillar Inc. recommends replacing the crankshaft vibration damper.

Oil Cooler Core

During an overhaul, Caterpillar Inc. recommends the removal of the oil cooler core. Clean the oil cooler core. Then, pressure test the oil cooler core.

NOTICE

Do not use caustic cleaners to clean the core.

Caustic cleaners can attack the internal metals of the core and cause leakage.

Note: Use this cleaning procedure to clean the oil cooler core.

1. Remove the oil cooler core.
2. Remove any debris from the oil cooler core. To remove debris from the oil cooler core, turn the oil cooler core onto one end.
3. Flush the oil cooler core internally with cleaner in order to loosen foreign substances. This flushing will also help to remove oil from the oil cooler core.

Note: Caterpillar Inc. recommends the use of Hydrosolv Liquid Cleaners. Table 19 lists the Hydrosolv Liquid Cleaners that are available from your Caterpillar dealer.

Table 19

Hydrosolv Liquid Cleaners		
Part Number	Description	Size
1U-8812	Hydrosolv 4165	4 L (1 US gallon)
1U-5490		19 L (5 US gallon)
8T-7570		208 L (55 US gallon)
1U-8804	Hydrosolv 100	4 L (1 US gallon)
1U-5492		19 L (5 US gallon)
8T-5571		208 L (55 US gallon)

- Use steam to clean the oil cooler core. The steam will remove any remaining residue from the cleaner. Flush the fins of the oil cooler core. Remove any other trapped debris.
- Wash the oil cooler core with hot, soapy water. Rinse the oil cooler core thoroughly with clean water.

WARNING

Personal injury can result from air pressure.

Personal injury can result without following proper procedure. When using pressure air, wear a protective face shield and protective clothing.

Maximum air pressure at the nozzle must be less than 205 kPa (30 psi) for cleaning purposes.

- Dry the oil cooler core with compressed air. Direct the air in the reverse direction of the normal flow.
- Inspect the components in order to ensure cleanliness. The oil cooler core should be pressure tested. Repair the oil cooler core, if necessary. Install the oil cooler core.

For more information about cleaning the cores, consult your Caterpillar dealer.

Obtain Coolant Analysis

The concentration of supplemental coolant additive (SCA) should be checked regularly with test kits or with S·O·S Coolant Analysis (Level 1). Further coolant analysis is recommended when the engine is overhauled.

For example, considerable deposits are found in the water jacket areas on the external cooling system, but the concentrations of coolant additives were carefully maintained. The coolant probably contained minerals that were deposited on the engine over time.

A coolant analysis can be conducted in order to verify the condition of the water that is being used in the cooling system. A full water analysis can be obtained by consulting your local water utility company or an agricultural agent. Private laboratories are also available for water analysis.

Caterpillar Inc. recommends an S·O·S Coolant Analysis (Level 2).

S·O·S Coolant Analysis (Level 2)

An S·O·S Coolant Analysis (Level 2) is a comprehensive coolant analysis which completely analyzes the coolant and the effects on the cooling system. An S·O·S Coolant Analysis (Level 2) provides the following information:

- Complete S·O·S Coolant Analysis (Level 1)
- Visual inspection of properties
- Identification of metal corrosion
- Identification of contaminants
- Identification of built up impurities (corrosion and scale)

S·O·S Coolant Analysis (Level 2) provides a report of the results of both the analysis and the maintenance recommendations.

For more information about coolant analysis, see your Caterpillar dealer.

i04020194

Radiator - Clean

SMCS Code: 1353-070

Note: Adjust the frequency of cleaning according to the effects of the operating environment.

Inspect the radiator for these items: damaged fins, corrosion, dirt, grease, insects, leaves, oil and other debris. Clean the radiator, if necessary.

WARNING

Personal injury can result from air pressure.

Personal injury can result without following proper procedure. When using pressure air, wear a protective face shield and protective clothing.

The maximum air pressure for cleaning purposes must be reduced to 205 kPa (30 psi) when the air nozzle is deadheaded.

Maintenance Recommendations

Starting Motor - Inspect

Pressurized air is the preferred method for removing loose debris. Direct the air in the opposite direction of the air flow. Hold the nozzle approximately 6 mm (0.25 inch) away from the fins. Slowly move the air nozzle in a direction that is parallel with the tubes. This movement will remove debris that is between the tubes.

Pressurized water may also be used for cleaning. The maximum water pressure for cleaning purposes must be less than 275 kPa (40 psi). Use pressurized water in order to soften mud. Clean the core from both sides.

Use a degreaser and steam for removal of oil and grease. Clean both sides of the core. Wash the core with detergent and hot water. Thoroughly rinse the core with clean water.

After cleaning, start the engine and accelerate the engine to high idle rpm. This procedure will help in the removal of debris and drying of the core. Stop the engine. Use a light bulb behind the core in order to inspect the core for cleanliness. Repeat the cleaning, if necessary.

Inspect the fins for damage. Bent fins may be opened with a "comb". Inspect these items for good condition: welds, mounting brackets, air lines, connections, clamps and seals. Make repairs, if necessary.

i02348493

Starting Motor - Inspect

SMCS Code: 1451-040; 1453-040

Caterpillar recommends a scheduled inspection of the starting motor. If the starting motor fails, the engine may not start in an emergency situation.

Check the starting motor for correct operation. Check the electrical connections and clean the electrical connections. Refer to the Systems Operation, Testing and Adjusting Manual, "Electric Starting System - Test" for more information on the checking procedure and for specifications or consult your Caterpillar dealer for assistance.

i04922217

Turbocharger - Inspect

SMCS Code: 1052-040

WARNING

Hot engine components can cause injury from burns. Before performing maintenance on the engine, allow the engine and the components to cool.

NOTICE

Turbocharger bearing failures can cause large quantities of oil to enter the air intake and exhaust systems. Loss of engine lubricant can result in serious engine damage.

Minor leakage of oil into a turbocharger under extended low idle operation should not cause problems as long as a turbocharger bearing failure has not occurred.

When a turbocharger bearing failure is accompanied by a significant engine performance loss (exhaust smoke or engine rpm up at no load), do not continue engine operation until the turbocharger is renewed.

A visual inspection of the turbocharger or turbochargers can minimize unscheduled downtime. A visual inspection of the turbocharger or turbochargers can also reduce the chance for potential damage to other engine parts. Do not inspect the engine with the engine in operation.

Engine Installed with Single Turbocharger

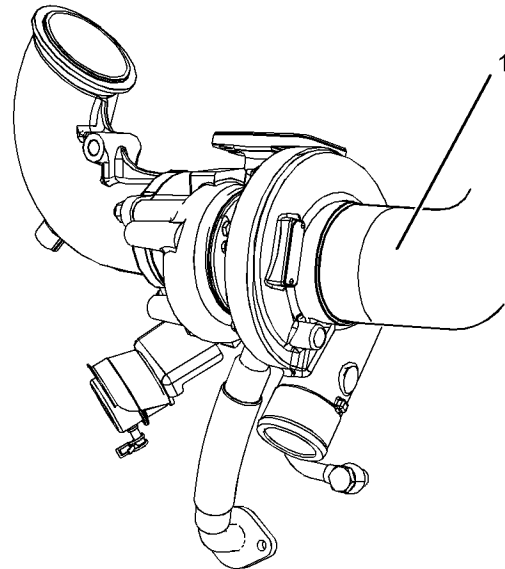

Illustration 102

g03089297

1. Ensure that the turbocharger is clean and free from dirt before removing components for inspection.
2. Remove the pipe from the turbocharger exhaust outlet and remove the air intake pipe (1). Visually inspect the piping for the presence of oil. Clean the interior of the pipes in order to prevent dirt from entering during reassembly.

3. Check for obvious heat discoloration of the turbocharger. Check for any loose bolts or any missing bolts. Check for damage to the oil supply line and the oil drain line. Check for cracks in the housing of the turbocharger. Ensure that the compressor wheel can rotate freely.
4. Check for the presence of oil. If oil is leaking from the back side of the compressor wheel, there is a possibility of a failed turbocharger oil seal.

The presence of oil may be the result of extended engine operation at low idle. The presence of oil may also be the result of a restriction of the line for the intake air (clogged air filters), which causes the turbocharger to slobber.

5. Install the air intake pipe and the exhaust outlet pipe to the turbocharger housing. Ensure that all clamps are installed correctly and that all clamps are tightened securely. For more information, refer to Systems Operation, Testing, and Adjusting, "Turbocharger - Inspect".

Engine Installed with High Pressure Turbocharger and Low Pressure Turbocharger

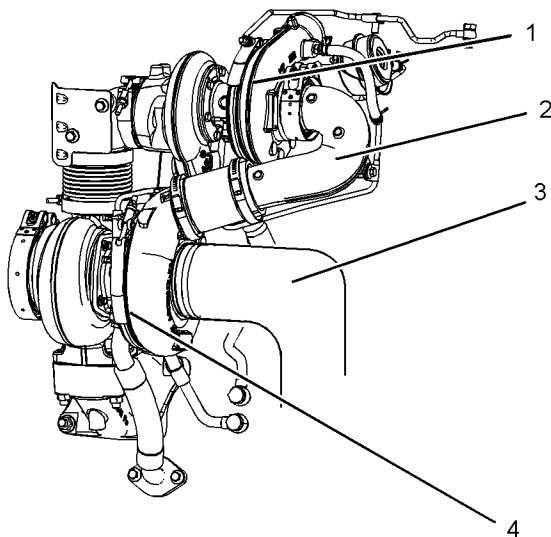

Illustration 103

g03089316

The engine is equipped with a high-pressure turbocharger (1) and a low-pressure turbocharger (4). A regular visual inspection of both turbochargers is recommended. If the turbocharger fails during engine operation, damage to the turbocharger compressor wheel and/or to the engine may occur. Damage to the turbocharger compressor wheel can damage the pistons, the valves, and the cylinder head.

1. Ensure that the turbochargers are clean and free from dirt before removing components for inspection.
2. Remove the pipe from the high-pressure turbocharger exhaust outlet and remove the air intake pipe (3) to the turbocharger. Visually inspect the piping for the presence of oil. Clean the interior of the pipes in order to prevent dirt from entering during reassembly.
3. Remove elbow (2) and check for the presence of engine oil.
4. Check for obvious heat discoloration of the turbocharger. Check for any loose bolts or any missing bolts. Check for damage to the oil supply line and the oil drain line. Check for cracks in the housing of the turbocharger. Ensure that the compressor wheel can rotate freely.
5. Check for the presence of oil. If oil is leaking from the back side of the compressor wheel, there is a possibility of a failed turbocharger oil seal.

The presence of oil may be the result of extended engine operation at low idle. The presence of oil may also be the result of a restriction of the line for the intake air (clogged air filters), which causes the turbocharger to slobber.

6. Inspect the bore of the housing of the turbine outlet for corrosion.
7. Install the air intake pipe and the exhaust outlet pipe to the turbocharger housing. Ensure that all clamps are installed correctly and that all clamps are tightened securely. For more information, refer to Systems Operation, Testing, and Adjusting, "Turbocharger - Inspect".

i05431557

Walk-Around Inspection

SMCS Code: 1000-040

Inspect the Tube of the Crankcase Breather

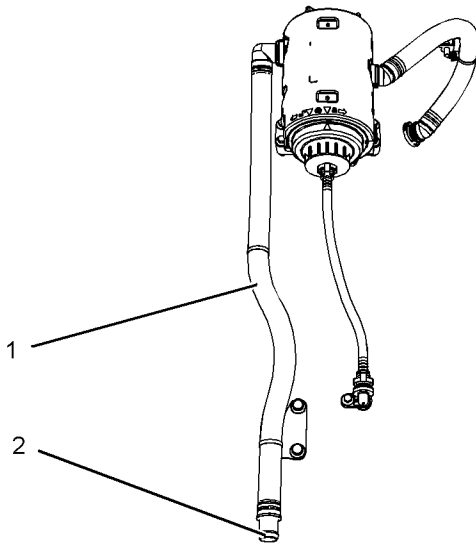

Illustration 104

g02351425

Typical example

Inspect the breather tube (1) for damage. Ensure that the outlet (2) is clean and free from any obstructions. Ice can cause obstructions in adverse weather conditions.

Inspect the Engine for Leaks and for Loose Connections

A walk-around inspection should only take a few minutes. When the time is taken to perform these checks, costly repairs and accidents can be avoided.

For maximum engine service life, make a thorough inspection of the engine compartment before starting the engine. Look for items such as oil leaks or coolant leaks, loose bolts, worn belts, loose connections, and trash buildup. Make repairs, as needed:

- The guards must be in the correct place. Repair damaged guards or replace missing guards.
- Wipe all caps and plugs before the engine is serviced in order to reduce the chance of system contamination.

NOTICE

For any type of leak (coolant, lube, or fuel) clean up the fluid. If leaking is observed, find the source and correct the leak. If leaking is suspected, check the fluid levels more often than recommended until the leak is found or fixed, or until the suspicion of a leak is proved to be unwarranted.

NOTICE

Accumulated grease and/or oil on an engine is a fire hazard. Remove the accumulated grease and oil. Refer to this Operation and Maintenance Manual, "Engine - Clean" for more information.

- Ensure that the cooling system hoses are correctly clamped and that the cooling system hoses are tight. Check for leaks. Check the condition of all pipes.
- Inspect the water pump for coolant leaks.

Note: The water pump seal is lubricated by the coolant in the cooling system. It is normal for a small amount of leakage to occur as the engine cools down and the parts contract.

Excessive coolant leakage may indicate the need to replace the water pump. Remove the water pump. Refer to Disassembly and Assembly, "Water Pump - Remove and Install". For more information, consult your Caterpillar dealer.

- Inspect the lubrication system for leaks at the front crankshaft seal, the rear crankshaft seal, the oil pan, the oil filters, and the rocker cover.
- Inspect the piping for the air intake system and the elbows for cracks and for loose clamps. Ensure that hoses and tubes are not contacting other hoses, tubes, wiring harnesses, etc.
- Ensure that the areas around the rotating parts are clear.
- Inspect the alternator belts and any accessory drive belts for cracks, breaks, or other damage.
- Inspect the wiring harness for damage.

Belts for multiple groove pulleys must be replaced as matched sets. If only one belt is replaced, the belt will carry more load than the belts that are not replaced. The older belts are stretched. The additional load on the new belt could cause the belt to break.

High Pressure Fuel Lines

WARNING

Contact with high pressure fuel may cause fluid penetration and burn hazards. High pressure fuel spray may cause a fire hazard. Failure to follow these inspection, maintenance and service instructions may cause personal injury or death.

After the engine has stopped, you must wait for 10 minutes in order to allow the fuel pressure to be purged from the high-pressure fuel lines before any service or repair is performed on the engine fuel lines. If necessary, perform minor adjustments. Repair any leaks from the low-pressure fuel system and from the cooling, lubrication, or air systems. Replace any high-pressure fuel line that has leaked. Refer to Disassembly and Assembly Manual, "Fuel Injection Lines - Install".

If you inspect the engine in operation, always use the proper inspection procedure in order to avoid a fluid penetration hazard. Refer to Operation and Maintenance Manual, "General hazard Information".

Visually inspect the high-pressure fuel lines for damage or signs of fuel leakage. Replace any damaged high-pressure fuel lines or high-pressure fuel lines that have leaked.

Ensure that all clips on the high-pressure fuel lines are in place and that the clips are not loose.

- Inspect the rest of the fuel system for leaks. Look for loose fuel line clamps.
- Drain the water and the sediment from the fuel tank on a daily basis in order to ensure that only clean fuel enters the fuel system.
- Inspect the wiring and the wiring harnesses for loose connections and for worn wires or frayed wires. Check for any loose tie-wraps or missing tie-wraps.
- Inspect the ground strap for a good connection and for good condition.
- Disconnect any battery chargers that are not protected against the current drain of the starting motor. Check the condition and the electrolyte level of the batteries, unless the engine is equipped with a maintenance free battery.
- Check the condition of the gauges. Replace any gauges that are cracked. Replace any gauge that cannot be calibrated.

Engine Aftertreatment

Check the condition of the coolant lines, Diesel Exhaust Fluid (DEF) lines, and electrical connections. Check that all clamps, clips, and tie-wraps are secure and in good condition. Check that the DEF filler cap is secure and that cap is clean and free from dirt.

Check the level of DEF in the tank is adequate for operational purpose, if necessary fill the tank.

i03570653

Water Pump - Inspect

SMCS Code: 1361-040

A failed water pump may cause severe engine overheating problems that could result in the following conditions:

- Cracks in the cylinder head
- A piston seizure
- Other potential damage to the engine

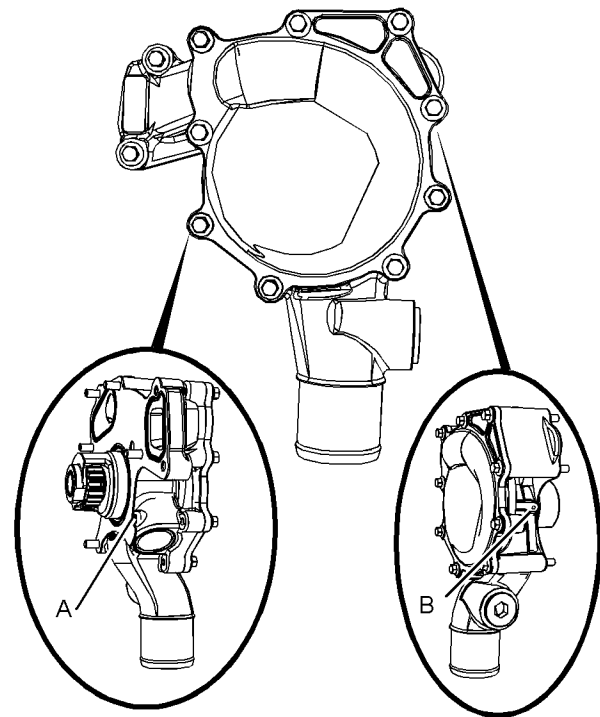

Illustration 105

g01904773

(A) Weep hole
(B) Vent hole

Note: The water pump seals are lubricated by the coolant in the cooling system. It is normal for a small amount of leakage to occur. Refer to illustration 105 for the position of the weep hole and the vent hole.

Maintenance Recommendations
Water Pump - Inspect

Visually inspect the water pump for leaks.

Note: If engine coolant enters the engine lubricating system the lubricating oil and the engine oil filter must be replaced. This will remove any contamination that is caused by the coolant and this will prevent any irregular oil samples.

The water pump is not a serviceable item. In order to install a new water pump, refer to the Disassembly and Assembly Manual, "Water Pump - Remove and Install".

Warranty Section

Warranty Information

i04141951

Emissions Warranty Information

SMCS Code: 1000

Caterpillar Inc. (Caterpillar) warrants to the ultimate purchaser and each subsequent purchaser that:

1. New non-road diesel engines and stationary diesel engines less than 10 liters per cylinder operated and serviced in the United States and Canada , including all parts of their emission control systems (“emission related components”), are:
 - a. Designed, built, and equipped so as to conform, at the time of sale, with applicable emission standards prescribed by the United States Environmental Protection Agency (EPA) by way of regulation.
 - b. Free from defects in materials and workmanship in emission-related components that can cause the engine to fail to conform to applicable emission standards for the warranty period.
2. New non-road diesel engines operated and serviced in the state of California , including all parts of their emission control systems (“emission related components”), are:
 - a. Designed, built, and equipped so as to conform, at the time of sale, to all applicable regulations adopted by the California Air Resources Board (ARB).
 - b. Free from defects in materials and workmanship which cause the failure of an emission-related component to be identical in all material respects to the component as described in the Caterpillar application for certification for the warranty period.

A detailed explanation of the Emission Control Warranty that is applicable to new non-road and stationary diesel engines, including the components covered and the warranty period, is found in supplement Special Publication, SELF9001, “Federal Emission Control Warranty” and “Emission Control Warranty for California”. Consult your authorized Cat dealer to determine if your engine is subject to an Emission Control Warranty.

Reference Information Section

Engine Ratings

i03579032

Engine Rating Conditions

SMCS Code: 1000

It is important to know the use of the engine so that the rating will match the operating profile. The proper rating selection is also important so that the customer's perception of price and value is realized.

In selecting a rating for a specific application, the most important consideration is the time that is spent at full throttle. The rating definitions identify the percent of time at full throttle. The definitions also identify the corresponding times below rated rpm.

Note: For an exact determination of the appropriate rating, follow the OEM specifications or consult your Caterpillar dealer.

There are five ratings from A to E. The rating for the C7.1 industrial engine is C.

C – Intermittent service in conjunction with maximum power and/or speed are cyclic. The engine at full load should not exceed 50 percent of the duty cycle.

NOTICE

Operating engines above the rating definitions can result in shorter service life before overhaul.

i04650089

Engine Rating Definitions

SMCS Code: 1000

All engine ratings are in compliance with the following standard ambient air conditions of ISO14396:2002:

- 100 kPa (29.3 Inches Hg)
- 30 percent relative humidity
- A temperature of 25 °C (77 °F)

The engine ratings are based on the following fuel specifications:

- The Low Heat Value (LHV) of the fuel at 29 °C (84.2 °F) at 42780 kJ/kg (18390 Btu/lb)
- Specific gravity of .833 - 837 at 15 °C (60 °F)

The engine ratings are gross output ratings.

Gross Output Ratings – The total output capability of the engine that is equipped with standard accessories.

Standard accessories include the following components:

- Oil pumps
- Fuel pumps
- Water pumps

Subtract the power that is required to drive auxiliary components from the gross output. This process will produce the net power that is available for the external load (flywheel).

Customer Service

i03996951

Customer Assistance

SMCS Code: 1000; 4450

USA and Canada

When a problem arises concerning the operation or the service of an engine, the problem will normally be managed by the dealer in your area.

Outside of the USA and of Canada

If a problem arises outside the USA and outside Canada, and if the problem cannot be resolved at the dealer level, consult the appropriate Caterpillar office.

Latin America, Mexico, Caribbean
Caterpillar Americas Co.
701 Waterford Way, Suite 200
Miami, FL 33126-4670
USA
Phone: 305-476-6800
Fax: 305-476-6801

Europe, Africa, and Middle East
Caterpillar Overseas S.A.
76 Route de Frontenex
P.O. Box 6000
CH-1211 Geneva 6
Switzerland
Phone: 22-849-4444
Fax: 22-849-4544

Far East
Caterpillar Asia Pte. Ltd.
7 Tractor Road
Jurong, Singapore 627968
Republic of Singapore
Phone: 65-662-8333
Fax: 65-662-8302

China
Caterpillar China Ltd.
37/F., The Lee Gardens
33 Hysan Avenue
Causeway Bay
G.P.O. Box 3069
Hong Kong
Phone: 852-2848-0333
Fax: 852-2848-0440

Japan
Shin Caterpillar Mitsubishi Ltd.
SBS Tower
10-1, Yoga 4-Chome
Setagaya-Ku, Tokyo 158-8530
Japan
Phone: 81-3-5717-1150
Fax: 81-3-5717-1177

Japan
Caterpillar Power Systems, Inc.
SBS Tower (14th floor)
4-10-1, Yoga
Setagaya-Ku, Tokyo 158-0097
Phone: 81-3-5797-4300
Fax: 81-3-5797-4359

Australia and New Zealand
Caterpillar of Australia Ltd.
1 Caterpillar Drive
Private Mail Bag 4
Tullamarine, Victoria 3043
Australia
Phone: 03-9953-9333
Fax: 03-9335-3366

i03655027

Ordering Replacement Parts

SMCS Code: 4450; 7567

WARNING

When replacement parts are required for this product Caterpillar recommends using Caterpillar replacement parts or parts with equivalent specifications including, but not limited to, physical dimensions, type, strength and material.

Failure to heed this warning can lead to premature failures, product damage, personal injury or death.

Quality Caterpillar replacement parts are available from Caterpillar dealers throughout the world. Caterpillar dealers' parts inventories are up-to-date. The parts stocks include all of the parts that are normally needed to protect your Caterpillar engine investment.

When you order parts, please specify the following information:

Customer Service
Ordering Replacement Parts

- When a Caterpillar engine requires maintenance and/or repair, provide the dealer with all the information that is stamped on the Information Plate. Refer to this Operation and Maintenance Manual, "Plate Locations and Film Locations".
- Part number
- Part name
- Quantity

If there is a question concerning the part number, please provide your dealer with a complete description of the needed item.

Discuss the problem with the dealer. Inform the dealer about the conditions of the problem and the nature of the problem. Inform the dealer about when the problem occurs. This will help the dealer in troubleshooting the problem and solving the problem faster.

Reference Materials

i05264255

Maintenance Records

SMCS Code: 1000; 4450

Caterpillar Inc. recommends the retention of accurate maintenance records. Accurate maintenance records can be used for the following purposes:

- Determine operating costs.
- Establish maintenance schedules for other engines that are operated in the same environment.
- Show compliance with the required maintenance practices and maintenance intervals.

Maintenance records can be used for various other business decisions that are related to engine maintenance.

Maintenance records are a key element of a maintenance program that is managed. Accurate maintenance records can help your Cat dealer to fine-tune the recommended maintenance intervals in order to meet the specific operating situation. This should result in a lower engine operating cost.

Records should be kept for the following items:

Fuel Consumption – A record of fuel consumption is essential in order to determine when the load sensitive components should be inspected or repaired. Fuel consumption also determines overhaul intervals.

Service Hours – A record of service hours is essential to determine when the speed sensitive components should be inspected or repaired.

Documents – These items should be easy to obtain, and these items should be kept in the engine history file. All of the documents should show this information: date, service hours, fuel consumption, unit number and engine serial number. The following types of documents should be kept as proof of maintenance or repair for warranty:

Keep the following types of documents as proof of maintenance for warranty. Also, keep these types of documents as proof of repair for warranty:

- Dealer work orders and itemized bills
- Owner repair costs
- Owner receipts
- Maintenance log

i05432178

Reference Material

SMCS Code: 1000; 4450

The following literature can be obtained through any Caterpillar dealer.

Lubricants

- Operation and Maintenance Manual, SEBU5898, "Cold Weather Recommendations"
- Operation and Maintenance Manual, SEBU6251, "Caterpillar Commercial Diesel Engine Fluids Recommendations"
- Special Publication, PEHP6001, "How To Take A Good Oil Sample"

Coolants

- Special Publication, PEHP4036, "Data Sheet - Extended Life Coolant"
- Special Publication, PEHP7057, "Data Sheet - S·O·S Coolant Analysis"
- Special Publication, SEBD0518, "Know Your Cooling System"
- Label, PEEP5027, "Extended Life Coolant/ Antifreeze"

Miscellaneous

- Service Manual, REG1139F, "Service Manual Contents Microfiche"
- Service Manual, UENR4452, "C7.1 Industrial Engines"
- Troubleshooting, UENR0668, "C7.1 Industrial Engines"
- Systems Operation, Testing, and Adjusting, UENR0666, "C7.1 Industrial Engines"
- Specifications, UENR0665, "C7.1 Industrial Engines."
- Disassembly and Assembly, UENR0667, "C7.1 Industrial Engines"
- Specifications, SENR3130, "Torque Specifications"
- Special Publication, PECP9067, "One Safe Source" English language for use in NACD
- Special Publication, SEBF8029, "Index to Guidelines for Reusable Parts and Salvage Operations"
- Special Publication, SEBF8062, "Procedure to Inspect and Clean Air Filters"
- Special Instruction, SEHS9031, "Storage Procedure for Caterpillar Products"
- Special Publication, NEHS0526, "Service Technician Application Guide"
- Special Publication, SEBU6251, "Caterpillar Commercial Diesel Engine Fluids Recommendations"
- Special Instruction, SEHS7633, "Battery Test Procedure"

Index

A

After Starting Engine.....	66
After Stopping Engine.....	75
Aftercooler Core - Clean/Test (Air-To-Air Aftercooler).....	88
Aftercooler Core - Inspect.....	88
Alarms and Shutoffs	37
Alarms.....	37
Shutoffs.....	37
Testing.....	38
Alternator - Inspect	88
Alternator and Fan Belts - Replace.....	89

B

Battery - Replace.....	89
Battery Disconnect Switch (If Equipped).....	41
Battery Electrolyte Level - Check	89
Battery or Battery Cable - Disconnect.....	90
Before Starting Engine	17, 64
Belt - Inspect.....	91
Belt Tensioner - Check.....	90
Burn Prevention.....	12
Aftertreatment System	12
Batteries.....	12
Coolant.....	12
Induction System	12
Oils.....	12

C

Cold Weather Operation.....	69
Hints for Cold Weather Operation.....	69
Idling the Engine	70
Recommendations for Coolant Warm Up	70
Recommendations for the Coolant	70
Viscosity of the Engine Lubrication Oil.....	70
Cold Weather Starting	64
Configuration Parameters.....	60
Customer Specified Parameters.....	61
System Configuration Parameters.....	60
Coolant (DEAC) - Change.....	91
Cooling Systems with Heavy Deposits or Plugging	93
Drain	91
Fill.....	93
Flush	92

Coolant (ELC) - Change	94
Drain	94
Fill.....	95
Flush	95
Coolant Extender (ELC) - Add.....	96
Coolant Level - Check	97
Coolant Sample (Level 1) - Obtain	97
Coolant Sample (Level 2) - Obtain	98
Cooling System Supplemental Coolant Additive (SCA) - Test/Add.....	99
Add the SCA, If Necessary	100
S·O·S Coolant Analysis	99
Test for SCA Concentration	99
Crankshaft Vibration Damper - Inspect.....	100
Viscous Damper.....	100
Crushing Prevention and Cutting Prevention ..	15
Customer Assistance.....	133
Outside of the USA and of Canada	133
USA and Canada	133
Customer Service	133

D

Diagnostic Flash Code Retrieval	59
Diagnostic Lamp.....	59
Diesel Exhaust Fluid - Fill	101
Diesel Exhaust Fluid Filter - Clean/Replace..	101
Diesel Exhaust Fluid in Cold Weather	73
Driven Equipment - Check.....	102

E

Electrical System	18
Grounding Practices	18
Emergency Stopping	74
Emergency Stop Button.....	75
Emissions Certification Film	31
Emissions Warranty Information.....	131
Engaging the Driven Equipment.....	67
Engine - Clean.....	102
Aftertreatment.....	102
Engine Air Cleaner Element (Dual Element) - Inspect/Clean/Replace	102
Cleaning the Primary Air Cleaner Elements	103
Servicing the Air Cleaner Elements	102
Engine Air Cleaner Element (Single Element) - Inspect/Replace	105

Engine Air Cleaner Service Indicator - Inspect..... 105 Test the Service Indicator..... 105	Maintenance 4 Maintenance Intervals..... 4 Operation 4 Overhaul 4 Safety..... 4
Engine Air Precleaner - Check/Clean..... 106	Fuel and the Effect from Cold Weather..... 72
Engine Crankcase Breather Element - Replace..... 106 Bottom Service..... 108 Check the System..... 109 Top Service 107	Fuel Conservation Practices..... 68
Engine Diagnostics..... 59	Fuel Filter (In-Line) - Replace 114
Engine Electronics..... 19	Fuel Related Components in Cold Weather 72
Engine Mounts - Inspect..... 109	Fuel Filters 72
Engine Oil and Filter - Change 111	Fuel Heaters 73
Drain the Engine Lubricating Oil 111	Fuel Tanks..... 72
Fill the Oil Pan..... 112	Fuel System - Prime 115
Replace the Oil Filter..... 112	Fuel System Primary Filter (Water Separator) Element - Replace 116
Engine Oil Level - Check..... 110	Install the New Filter Element 117
Engine Oil Sample - Obtain 110	Remove the Element 116
Obtain the Sample and the Analysis..... 110	Fuel System Primary Filter/Water Separator - Drain 118
Engine Operation..... 67	Fuel System Secondary Filter - Replace 118
Engine Operation and the Aftertreatment System 67	Install the Element 119
Engine Operation with Active Diagnostic Codes 59	Remove the Element 118
Engine Operation with Intermittent Diagnostic Codes..... 60	Fuel Tank Water and Sediment - Drain..... 120
Engine Rating Conditions..... 132	Drain the Water and the Sediment..... 120
Engine Rating Definitions 132	Fuel Storage Tanks 120
Engine Ratings 132	Fuel Tank 120
Engine Starting 17, 64	
Engine Stopping 18, 74	
F	G
Fan Clearance - Check..... 113	Gauges and Indicators 41
Fault Logging..... 59	Aftertreatment Lamps and gauges..... 42
Features and Controls..... 37	Indicator Lamps 42
Fire Prevention and Explosion Prevention 13	General Hazard Information 8
Ether 14	Containing Fluid Spillage..... 10
Fire Extinguisher..... 14	Dispose of Waste Properly..... 11
Lines, Tubes, and Hoses 15	Fluid Penetration..... 10
Fluid Recommendations..... 76	Inhalation 11
Coolant..... 81	Pressurized Air and Water 10
Diesel Exhaust Fluid 79	General Information..... 21
Engine Lubrication Oil..... 76	
Fuel 78	H
Lubricating Grease..... 78	High Pressure Fuel Lines 15
S·O·S Coolant Analysis 81	Hoses and Clamps - Inspect/Replace..... 120
Foreword..... 4	Replace the Hoses and the Clamps 121
California Proposition 65 Warning 4	
Literature Information..... 4	I
	Important Safety Information 2
	Injector (Diesel Exhaust Fluid) - Replace 121

L

Lifting and Storage..... 33

M

Maintenance Interval Schedule 87

Daily 87

Every 1000 Service Hours 87

Every 12 000 Service Hours or 6 Years 88

Every 1500 Service Hours 87

Every 2000 Service Hours 87

Every 250 Service Hours 87

Every 3000 Service Hours 87

Every 3000 Service Hours or 2 Years 87

Every 4000 Service Hours 87

Every 50 Service Hours or Weekly 87

Every 500 Service Hours 87

Every 500 Service Hours or 1 Year 87

Every 5000 Service Hours 87

Every 6000 Service Hours or 3 Years 88

Every Week..... 87

Every Year..... 87

Overhaul 88

When Required 87

Maintenance Log 136

Maintenance Recommendations 83

Maintenance Records..... 135

Maintenance Section 76

Model View Illustrations..... 21

Engine Aftertreatment System 26

Engine Views with Series Turbochargers 22

Off Engine Components..... 25

Single Turbocharged Engine with Installed
Aftertreatment 21Monitoring System (Engine Indicators and
Aftertreatment Indicators) 43

Engine Indicator Lamps 43

Mounting and Dismounting..... 15

O

Operation Section..... 33

Ordering Replacement Parts 133

Overhaul Considerations..... 123

Oil Consumption as an Overhaul Indicator
..... 123

Overhaul Recommendation 123

Overspeed 44

P

Plate Locations and Film Locations..... 30

Serial Number Plate 30

Plate Locations and Film Locations
(Aftertreatment System)..... 30

Clean Emission Module (CEM)..... 30

Pump Electronic Tank Unit (PETU)..... 31

Product Description (Engine and
Aftertreatment)..... 27Aftermarket Products and Caterpillar Engines
..... 29

Aftertreatment System 29

Electronic Engine Features..... 28

Engine Cooling and Lubrication..... 29

Engine Diagnostics 28

Engine Service Life 29

Engine Specifications 28

Product Identification Information 30

Product Information Section 21

Product Lifting..... 33

Engine and Clean Emission Module (CEM)
..... 33

Product Storage..... 35

Aftertreatment..... 35

R

Radiator - Clean..... 125

Radiator Restrictions 71

Reference Information 32

Record for Reference..... 32

Reference Information Section 132

Reference Material 137

Coolants..... 137

Lubricants 137

Miscellaneous 137

Reference Materials 135

Refill Capacities..... 76

Cooling System..... 76

Lubrication System 76

S

Safety Messages 5

Ether Warning 2 6

Hand (High Pressure) 3 7

Universal Warning 1 5

Safety Section 5

Selective Catalytic Reduction Warning
System..... 38

Warning Indicators	38	Welding on Engines with Electronic Controls ..	83
Warning Levels	38		
Warning Strategy	38		
Self-Diagnostics.....	59		
Sensors and Electrical Components	44		
Aftertreatment Components.....	54		
CEM Sensors.....	55		
Clean Emissions Module (CEM).....	54		
Engine Components	45		
Pump Electronic Tank Unit (PETU).....	57		
Severe Service Application.....	85		
Improper Maintenance Procedures (Maintenance Procedures Which May Contribute to a Severe Service Application)	86		
Severe Environmental Factors	85		
Severe Operating Conditions.....	85		
Starting Motor - Inspect	126		
Starting the Engine	65		
Starting the Engine	65		
Starting with Jump Start Cables	65		
Stopping the Engine	74		
Delayed Engine Shutdown (if Equipped).....	74		
System Pressure Release	83		
Coolant System.....	83		
Engine Oil	83		
Fuel System.....	83		

T

Table of Contents.....	3
Turbocharger - Inspect	126
Engine Installed with High Pressure Turbocharger and Low Pressure Turbocharger.....	127
Engine Installed with Single Turbocharger	126

W

Walk-Around Inspection	128
Engine Aftertreatment.....	129
High Pressure Fuel Lines.....	129
Inspect the Engine for Leaks and for Loose Connections.....	128
Inspect the Tube of the Crankcase Breather	128
Warranty Information	131
Warranty Section	131
Water Pump - Inspect	129

Product and Dealer Information

Note: For product identification plate locations, see the section "Product Identification Information" in the Operation and Maintenance Manual.

Delivery Date: _____

Product Information

Model: _____

Product Identification Number: _____

Engine Serial Number: _____

Transmission
Serial Number: _____

Generator Serial Number: _____

Attachment Serial Numbers: _____

Attachment Information: _____

Customer Equipment Number: _____

Dealer Equipment
Number: _____

Dealer Information

Name: _____ Branch: _____

Address: _____

	<u>Dealer Contact</u>	<u>Phone Number</u>	<u>Hours</u>
Sales:	_____	_____	_____
Parts:	_____	_____	_____
Service:	_____	_____	_____

